

CRAPAUD POUR ECHELLE EDF ET U24 CLMU

CLMU CLAMP FOR EDF LADDER AND U24

ZnMg

ZnMg

CABLOFIL®

INNOVATORS IN CABLE MANAGEMENT

FT0497-10 01-20

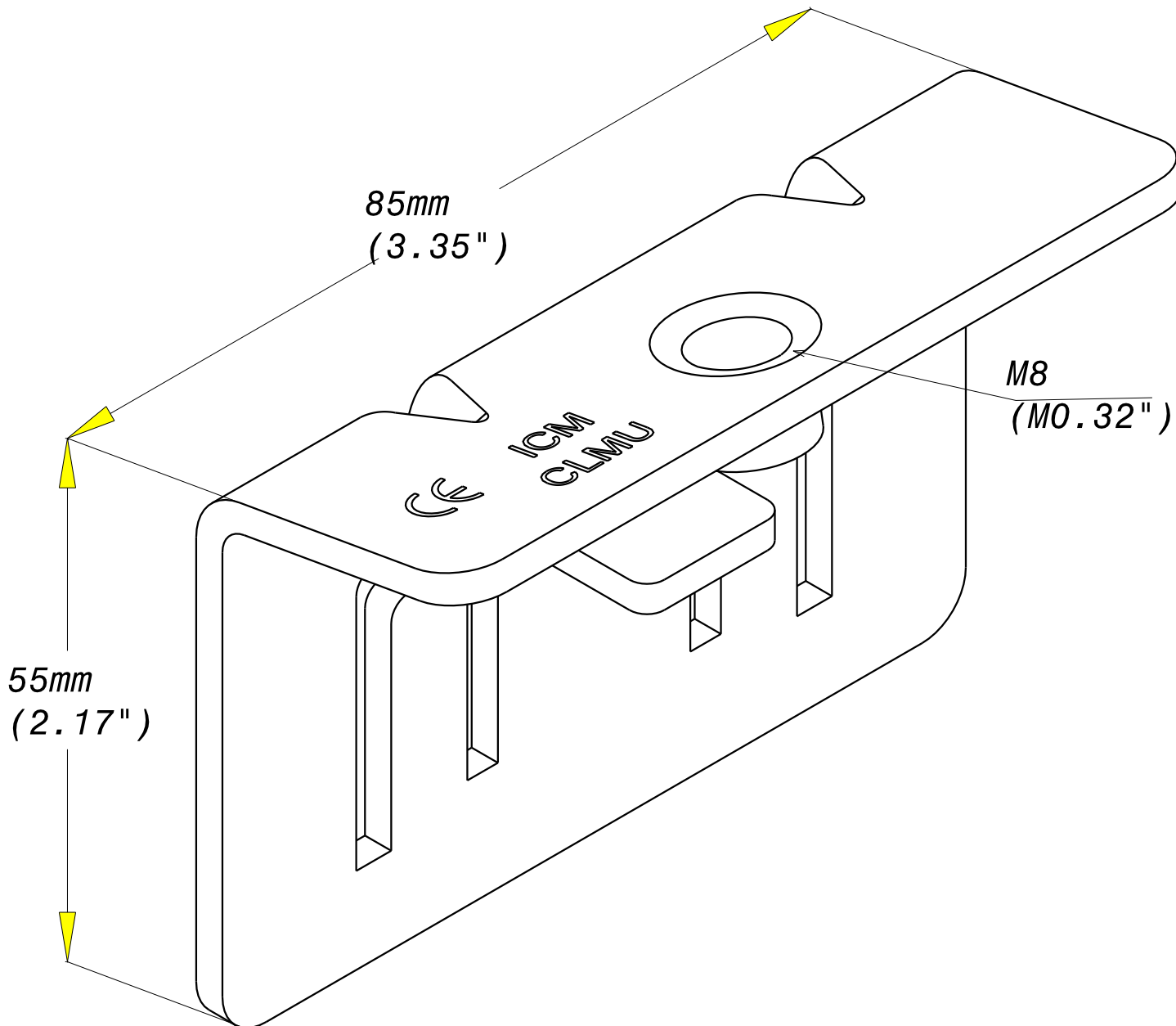

REF	CODE	POIDS (Kg)	WEIGHT (lb)	EPAISSEUR / THICKNESS
CLMU	559 097	0.150	0.330	3 (0.12")

Material	Standard
DX 51 D ZM	EN 10 346
Finition Coating	Standard
ZnMg	Class 8 according to CEI 61537

Propriété exclusive de CABLOFIL, ne peut être ni copié, ni transmis à des tiers sans autorisation écrite.

Exclusive property of CABLOFIL shouldn't be reproduced or transmitted to any people without written authorization