



ENERGY-3-Opti-100

Wi-MEF-3-Opti-100

3-phase
energy consumption monitor



www.fif.com.pl/fox/energy3



F&F Filipowski L.P.; Konstytucyjna 79/81, 95-200 Pabianice, POLAND
www.fif.com.pl; e-mail: biuro@fif.com.pl

Application

- » Monitoring of energy consumption in domestic installations;
- » Ongoing measurement of power consumption and values of currents and voltages;
- » Use of recorded measurements to detect exceedances in voltage levels or power consumption;
- » Controlling energy production in photovoltaic installations;
- » Metering of heat pumps.

Properties

- » 3-phase, 2-way, 4-quadrant electricity consumption monitor, perfect for monitoring photovoltaic installations, among other things;
- » Monitoring of all relevant electrical network parameters;
- » Recording of average, minimum and maximum values;
- » Measuring range up to 100 A;
- » Non-invasive installation using open-ended current transformers for conductors up to 16 mm in diameter;
- » High measurement accuracy;
- » Access to measurement history via app or web browser;
- » Communication via home Wi-Fi network and remote access via the F&F Polish cloud;
- » REST API and MQTT support to integrate the controller with external systems (including Home Assistant, among others);
- » Free mobile apps for Android and iOS;
- » Fully Polish solution focused on security and user privacy;
- » No hidden running costs and guaranteed long-term product support;
- » Mounting in a distribution box (DIN rail);
- » Including 3 current transformers;
- » Built-in antenna - easier installation in shallow switchboards*.

* Consideration should be given to Wi-Fi access at the device's mounting location. Switchgear enclosures made of metal can effectively limit Wi-Fi signal levels.

Configuration

For the initial configuration of the Fox module, it is necessary to download and run the free Fox application available for mobile devices running the system:

- » Android, version 8.0 or higher;
- » iOS, version 14 or higher.

You can download the app directly from the stores:



or via the website:

www.fif.com.pl/fox



On the above page, you can also find detailed information on how to configure and operate the devices and the Fox mobile app.

Wiring diagram

Supply

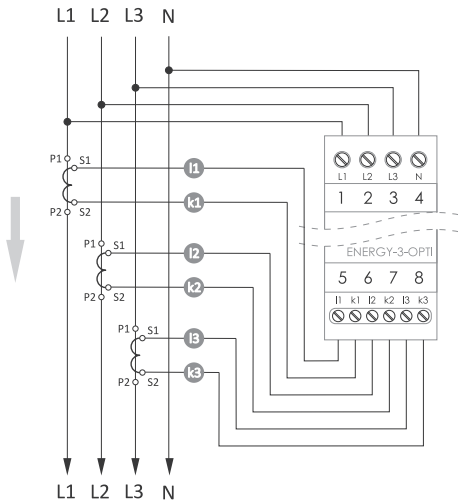

Reception



The correct type of measuring transformer must be set in the Fox application (for the Energy 3 module): **Module settings** → **Measuring transformer**.

Description of terminals

Power supply and voltage measurement (top row of terminals)

L1	L1 phase
L2	L2 phase
L3	L3 phase
N	neutral wire



Connecting the phase wire to the N terminal may damage the device.



The unit is designed for 3-phase, 4-wire mains operation. Leaving the neutral wire unconnected may lead to incorrect operation or damage to the device!



It is recommended to protect voltage inputs with 0.25÷0.5 A delayed fuse links, e.g. LK-BZ-3 (example p. 7).

Measuring transformers (bottom row of terminals)

I1 - k1	L1 phase transformer
I2 - k2	L2 phase transformer
I3 - k3	L3 phase transformer



Terminals intended only for connecting current transformers supplied with the meter or dedicated TOM-xxx-03 transformers manufactured by F&F with a rated secondary side current of 30 mA. Connecting a transformer with a higher secondary side current may damage the device.



Direct connection of a voltage source (especially mains voltage) to the terminals of the transformer may damage the device.



By default, the device is designed to connect TOM-100-03 current transformers with a rated current of 100 A. If other transformers are used, the device setting must also be changed accordingly (**Fox app** → **Device settings** → **Current transformer**).



Care must be taken to ensure that the phase sequence of the voltage and current circuits is correct. A phase sequence error will result in incorrect measurement of power consumption and energy consumption.



The order in which the current transformer outputs are connected and the direction in which the cable is passed through the transformer are also very important. Changing the order leads to a change in the sign of the direction of energy flow and power consumption. The correct installation is shown on page 8.

An example wiring diagram of the Energy-3 meter with voltage circuit protection by means of the LK-BZ-3 triple fuse link is shown in the figure below:

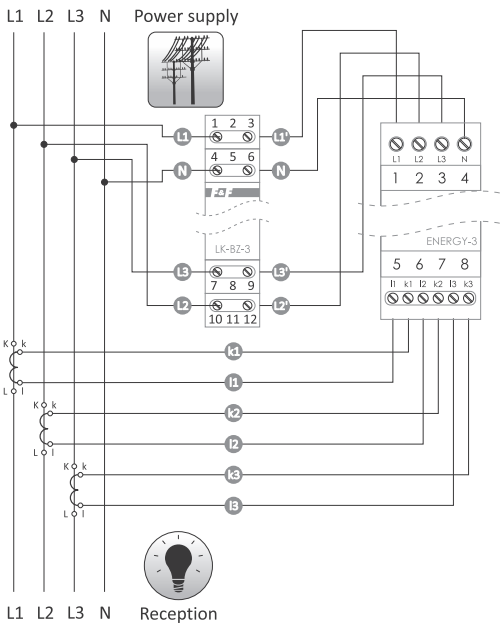

Mounting of measuring transformers

Miniature, open-ended current transformers are supplied with the unit. No interference with the current leads is required to clip them onto the measured leads, but special attention must be paid to the way the lead is passed through the transformer and to the connection of the secondary side of the transformer to the device. The correct method of installation is shown in the figure below:

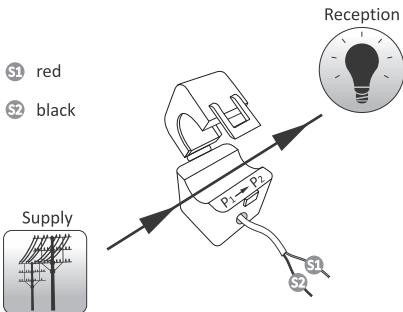

Customisation

Once you have connected your new device to the power supply, it is advisable to carry out personalisation, i.e. linking it to your phone and user account. To do this, launch the Fox app, select settings  icon, then **Add new device** command.



If you are running the application on your phone for the first time, follow the programme's instructions to register a user account or log in to an existing account, then select **Fox Wi-Fi: Search and configure wireless devices**.



Personalisation of the controller takes place via a direct connection. Due to the limited range of such a connection, it is recommended to carry out personalisation while standing directly at the controller.



Fox controllers only support 2.4 GHz Wi-Fi connections. **It is not possible to connect the controller to a 5 GHz network!**

When the search process is complete, the new Fox devices will be displayed. The Energy 3 module will appear in the list as follows:

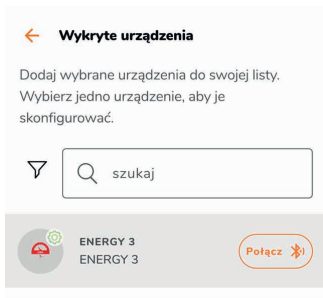

To add a new device, you must first connect to it (press **Connect** button), and once it has been established (figure below), press **Configure** button and continue following the application's instructions.

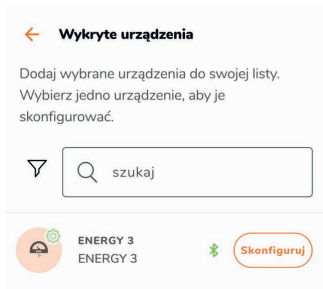

Telemetry

Fox Energy 3 allows energy consumption and monitored network parameters to be recorded. Data can be accessed directly from the application (Telemetry command visible in the device context menu) or via any web browser.

(address <https://telemetron.fhome.cloud>).



Starting data logging requires entering the module settings and selecting the **Telemetry** option. **Data logging and access to measurement history requires configured remote access.**



Data logging requires the meter to have constant access to the internet. In its absence, current readings of voltages, currents and power are lost. The last energy meter status is stored in the meter's memory and saved to the database when the internet connection is restored.



Energy consumption data will be stored in the database for a minimum of 10 years, after which they will be overwritten by more recent readings. Other network parameters (voltages, currents, powers) will be stored in the database for a minimum of 3 months, after which they will be overwritten by more recent readings.

LED signalling

The status of the module can be directly assessed by the **STATUS** LED located on the front of the device.



The grey color actually corresponds to the green LED and the black color to the red LED.



Controller
in factory mode

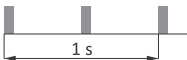

Connecting to
a Wi-Fi network

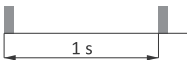

Connection to Wi-Fi
network established



No connection
to Wi-Fi network



Restoring firmware

Energy consumption signalling

Three LED lights (L1, L2, L3) on the front of the unit on the right-hand side are used to indicate the presence of voltage and power consumption. A light on indicates the presence of voltage on a given measuring circuit. A short blink indicates active energy consumption: 1 pulse = 1 Wh.

Restore factory settings

In case of lack of access to the controller, for example due to lost passwords, it is recommended that you reset the access passwords and then reconnect and configure the controller using the Fox application.

To reset passwords:

1. While the controller is operating, press and hold the **RESET** button on the front of the controller. When the button is pressed, the green LED (**STATUS**) will start to flash rapidly.
2. After about 5 seconds, the green LED (**STATUS**) will turn off and you should release the **RESET** button.
3. Press the **RESET** button briefly, the green LED (**STATUS**) will light up again.
4. Press and hold down the **RESET** button. After about 3 seconds, the previously switched on green LED (**STATUS**) will start to flash. After another 3 seconds, it will go out and the red LED (**ERROR**) light up.
5. Release the button - after a few seconds the red LED (**ERROR**) switches off, the green LED (**STATUS**) switches on and the controller restarts.
6. After completing this procedure, the access passwords and parameters for remote access have been cleared. You can now search for your device again in the app and personalize it again.

Technical data

installation	3-phase, 4-wire
power supply	3×230/400 V AC (-25%÷15%)
frequency	50÷60 Hz
accuracy	
meter	1%
measuring transformers	0.5%
transformer parameters	
primary current	100 A
secondary current	30 mA
cable diameter	≤15 mm
signalling	power presence, energy consumption
meter constant	1000 pulses/kWh
power consumption	<2 W
communication	
radio frequency	2.4 GHz
transmission	Wi-Fi
radio power (IEEE 802.11n)	<20 dBm
receiver sensitivity	-98 dBm
antenna	built-in
terminal	2.5 mm ² screw terminals (cord) 4.0 mm ² screw terminals (wire)
tightening torque	0.5 Nm
working temperature	-20÷50°C
humidity	<90%
(no condensation of steam and aggressive gases)	
dimensions	2 modules (35 mm)
mounting	on TH-35 rail
ingress protection	IP20

Warranty

F&F products are covered by a 24-month warranty from the date of purchase. The warranty is only valid with proof of purchase. Contact your dealer or contact us directly.

CE declaration

F&F Filipowski L.P. declares that the device is in conformity with the essential requirements of Directive 2014/53/EU of the European Parliament and of the Council of 16 April 2014 on the harmonisation of the laws of the Member States relating to the making available on the market of radio equipment and repealing Directive 1999/5/EC.

The CE Declaration of Conformity, along with the references to the standards in relation to which conformity is declared, can be found on www.fif.com.pl on the product page.