



79/81 Konstantynowska
Street, 95-200 Pabianice
tel/fax 42-2152383, 2270971
e-mail: fif@fif.com.pl

Softstart

SF-110 - SF-550

User manual

v. 1.1.1

Safety information regarding the use of the soft starter is indicated by symbols. All information and instructions marked with these symbols must be strictly observed.





| | |
|---|---|
|  | Risk of electric shock. |
|  | Potentially hazardous situation which may result in a risk to operating personnel or damage to the soft starter or motor. |
| Information regarding the construction, operation and handling of the soft starter. | |
|  | Important information, useful tip. |
|  | Practical advice, solution to a problem. |
|  | Example of application or operation. |

Table of contents

| | |
|---|----|
| Part 1. Checking after unpacking | 4 |
| Rating plate | 4 |
| Part 2. Installation..... | 5 |
| Safety measures | 5 |
| Fittings..... | 5 |
| Part 3. Wiring..... | 7 |
| Wiring diagram | 7 |
| Power circuit wiring | 8 |
| Control circuit wiring | 9 |
| Part 4. Control panel..... | 12 |
| Description of control panel components | 12 |
| Monitor | 13 |
| Edit parameters | 16 |
| Part 5. Configuration..... | 17 |
| List of parameters | 17 |
| Start-up mode..... | 20 |
| Maximum current limit | 20 |
| Linear voltage rise | 21 |
| Soft start and current limiting | 23 |
| Soft start and linear voltage rise | 24 |
| Linear current rise | 25 |
| Dual voltage and current control..... | 25 |
| Direct with parameter control | 25 |
| Stopping the engine..... | 26 |
| Safety features..... | 27 |
| List of safety features | 27 |
| Protection characteristics | 28 |
| Part 6 – RS-485 communication | 29 |
| Communication parameters | 29 |
| List of registers | 30 |
| Part 7 – Fault detection and rectification..... | 31 |
| Error codes | 31 |
| Device Specifications..... | 33 |
| Warranty..... | 35 |

Part 1. Check after unpacking

Before installing and commissioning the soft starter, you must:

- 1) Check that the unit has not been damaged during transport
- 2) Check the nameplate on the unit to ensure that the product received matches the order.

In the event of any damage, missing items or discrepancies, please contact the supplier immediately.

Rating plate

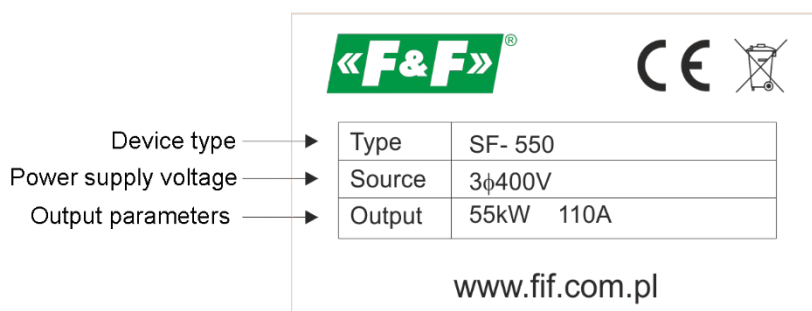

Fig. 1: Soft starter nameplate











| Type | Input voltage | Output current | Maximum motor power |
|---------------|---------------|----------------|---------------------|
| | V | A | kW |
| SF-110 | 3x400V | 22A | 11kW |
| SF-150 | 3x400V | 30A | 15kW |
| SF-180 | 3x400V | 37A | 18kW |
| SF-220 | 3x400V | 44A | 22kW |
| SF-300 | 3x400V | 60A | 30kW |
| SF-370 | 3x400V | 74A | 37kW |
| SF-450 | 3x400V | 90A | 45kW |
| SF-550 | 3x400V | 110A | 55kW |

Table 1: Type table

| | | |
|--|--|--|
| | When selecting the type of soft starter for a motor, one should first take into account the motor's rated and actual current, and subsequently the motor's power | |
|--|--|--|

Part 2. Installation

Safety precautions

| | | |
|---|---|---|
|  | Before starting the installation of the device, it is essential to read the user manual and follow the instructions contained therein. |  |
|  | Installation, commissioning and configuration of the soft starter must be carried out by qualified and authorised personnel. The following must be taken into account all applicable safety requirements. |  |
|  | Foreign objects, such as cable sleeves electrical cable insulation or metal filings left over from the installation of the control cabinet. |  |
|  | Once the power supply to the device has been switched on, no installation or inspection work must be carried out on the device. |  |
|  | The soft-starter's neutral terminal must be connected securely and effectively to the of the control cabinet and the electrical installation. |  |

Installation

To ensure correct and safe operation, the soft starter must be installed in a vertical position on a non-combustible wall or mounting plate. In addition, the installation must ensure that the following conditions are met:

- 1) Ambient temperature within the range $-10...+40^{\circ}\text{C}$
- 2) Air circulation between the soft starter housing and the surroundings must be ensured
- 3) Protection against the ingress of water droplets, water vapour, dust, iron filings and other foreign bodies.
- 4) Protection against the effects of oils, salts, corrosive and explosive gases.
- 5) Ensuring adequate clearance between the soft starter and adjacent objects in accordance with Fig. 2 on page 6

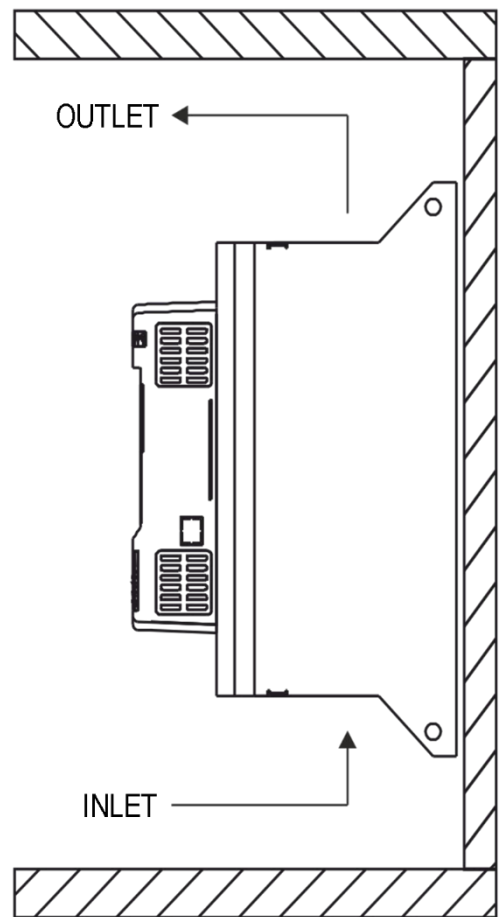
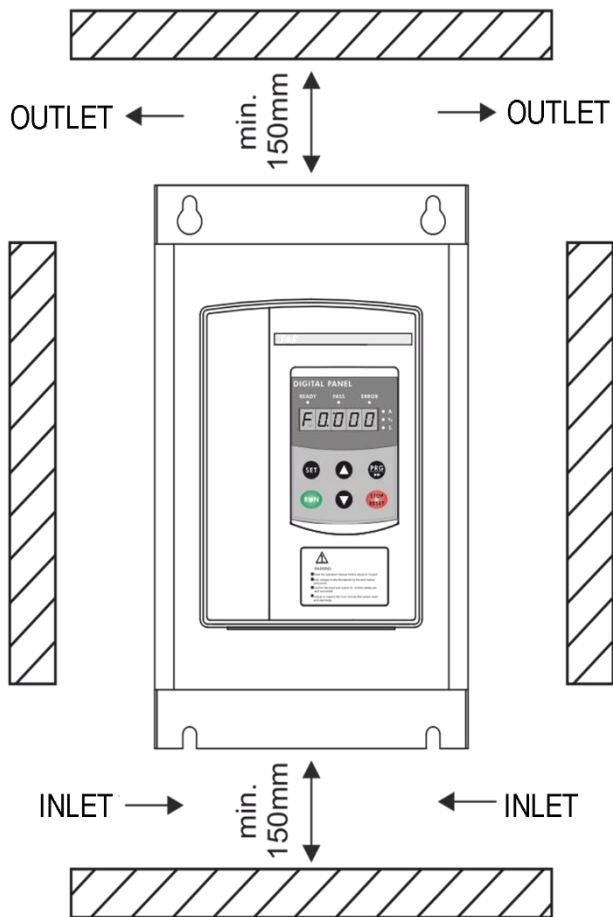

Fig. 2: Example of correct soft starter installation

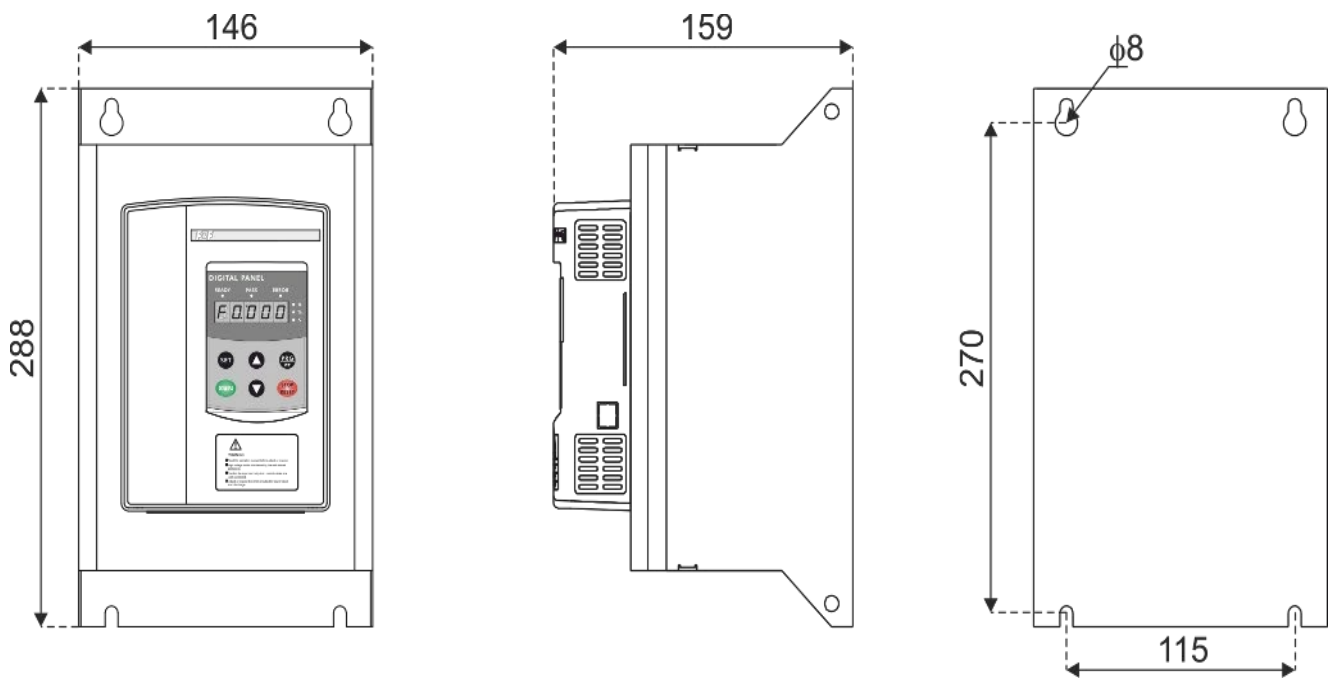

Fig. 3: Soft starter dimensions and mounting holes

Part 3. Wiring

Wiring diagram

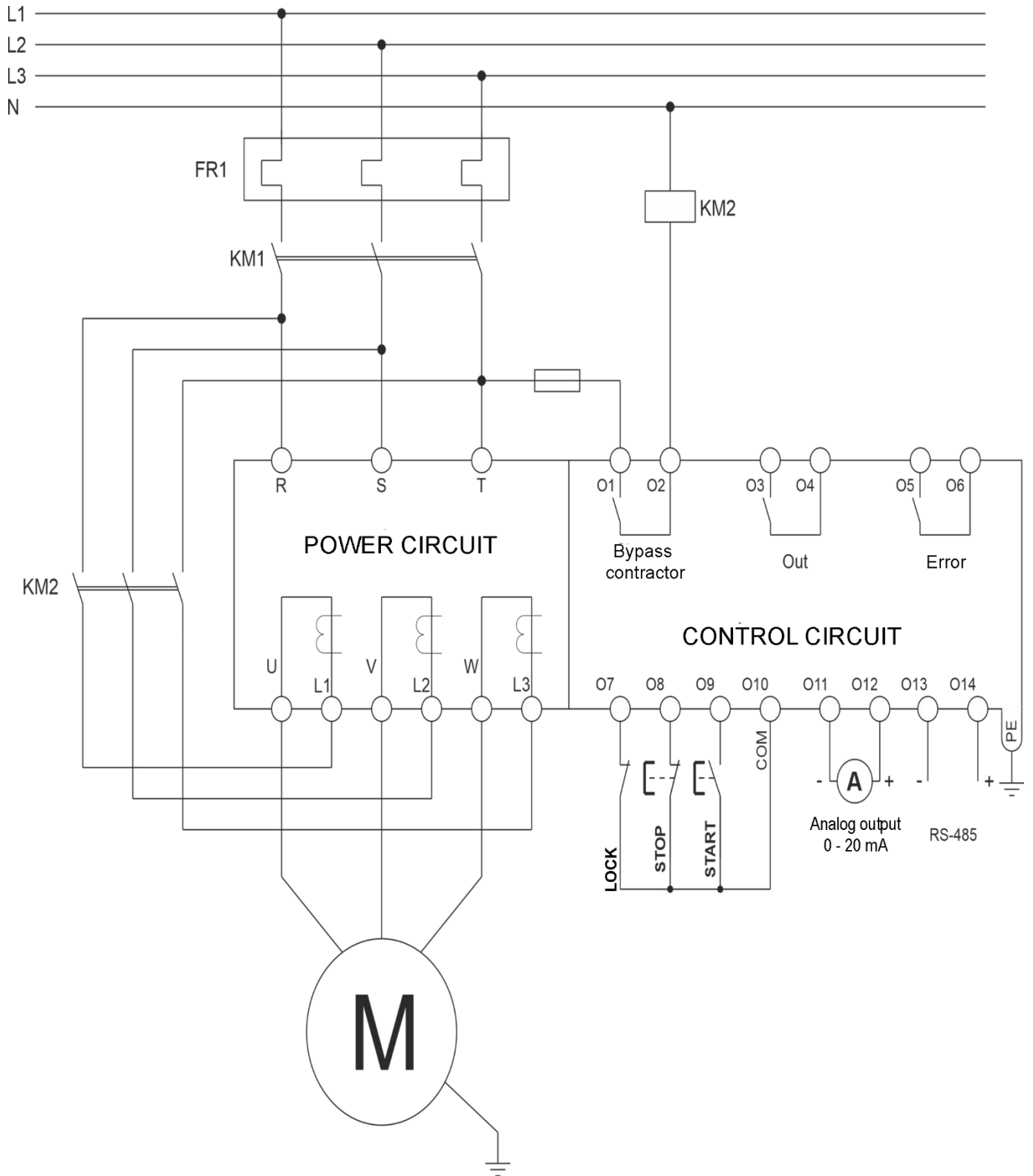





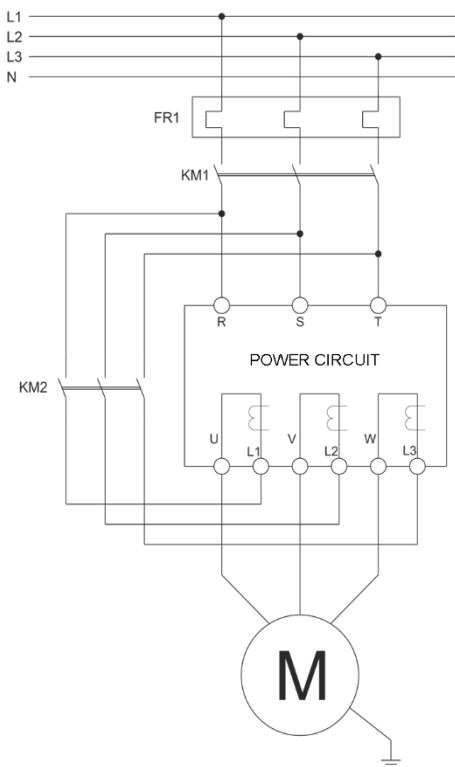

Fig. 4: Wiring diagram

Power circuit wiring

| | | |
|---|--|---|
|  | The soft-start power supply must be connected in accordance with all applicable standards. The minimum cross-sectional area of the power supply cables and the rating of the overload protection devices must be appropriate for the power and the anticipated starting characteristics. |  |
|  | Basic motor protection is provided by the soft-starter's control circuits. However, due to the need to protect against emergency situations (e.g. damage to the contactor or soft starter), it is recommended to use an FR1 overload protection device with a trip current adapted to the motor's rated current and to the expected starting characteristics, in accordance with the diagram shown in Fig. 5a. For machines with a heavy start-up, it is worth considering the use of two overload protection devices. FR1 – for start-up and stop, with characteristics matched to the expected starting current. And relay FR2 to protect the motor during operation, with characteristics matched to the motor's rated current (Fig. 5b). |  |
|  | The KM2 bypass contactor is essential for the correct operation of the device. The parameters of the contactor used must be adapted to the size connected electric motor. |  |



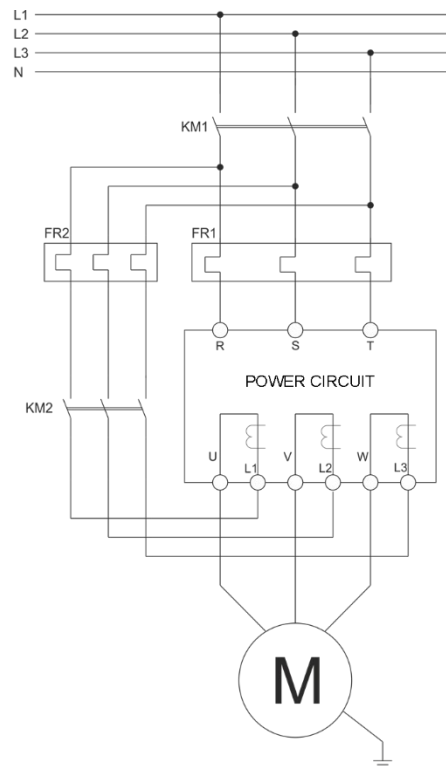

a) A single overload protection









b) Two overload protection devices

Fig. 5: Connecting the power circuit

| | | |
|---|--|---|
|  | When connecting the power circuits, particular attention must be paid to the of the phases on the terminal pairs R – L1 – U, S – L2 – V, T – L3 – W. |  |
|---|--|---|

| Terminal | Function | Notes |
|----------|------------------|--|
| R | Power supply | |
| S | | |
| T | | |
| U | Motor | Terminals for connecting the motor (top row of terminals) |
| V | | |
| W | | |
| L1 | Bypass contactor | Terminals for connecting the secondary side of the bypass contactor (lower row of terminals) |
| L2 | | |
| L3 | | |

Wiring of control circuits

| | | |
|---|---|---|
|  | Particular attention must be paid to isolating the control circuits from the power circuits. Accidental connection of the two circuits poses a risk of electric shock to the operator and/or damage to the equipment. |  |
|  | Binary inputs O7–O9 are potential-free and designed to be short-circuited with the COM level (input O10) of the soft-start unit. Connecting an external voltage to them may damage the device. |  |
|  | When using the analogue current output (terminals O11 – O12), the use of shielded cables is recommended. |  |

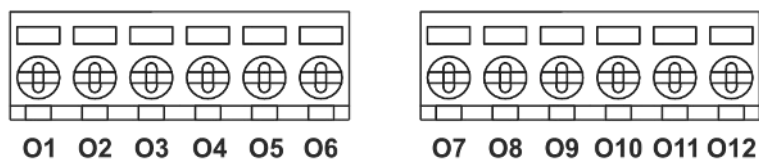

Fig. 6: View of the control circuit terminal block

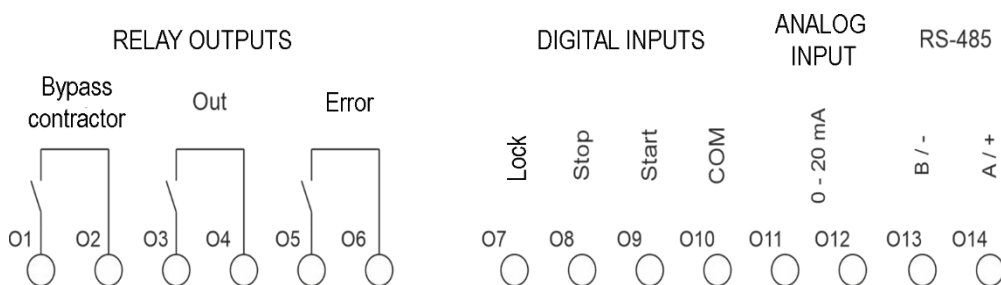

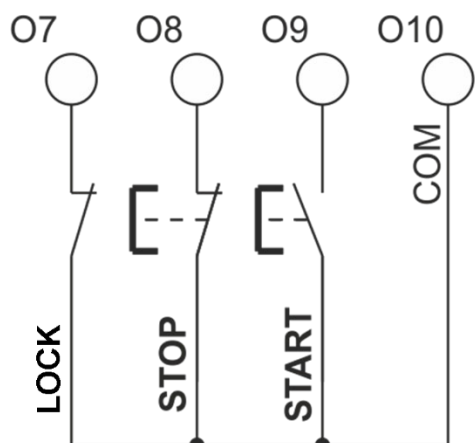

Fig. 7: Functions of the control circuit terminals

| Terminal | Function | Notes |
|----------|---------------------|--|
| O1 | Bypass contactor | <p>A NO contact is connected to terminals O1 and O2. Once the start-up is complete, this contact closes. This causes the bypass contactor to close and, from that point onwards, the motor is powered directly from the mains (bypassing the soft-start circuits).</p> <p> Note: If the bypass contactor is missing or faulty, the motor will stop once the start-up is complete</p> |
| O2 | | |
| O3 | Out | Programming the relay output |
| O4 | | |
| O5 | Error | Error indication |
| O6 | | |
| O7 | Interlock | <p>NC potential-free input. If the connection between terminals O7 (Interlock) and O10 (COM) is interrupted, the motor will stop and the soft starter will report an error.</p> <p> The lockout input can be used to implement all kinds of additional safety functions, e.g.: exceeding the maximum motor temperature, pressing the safety button , etc.</p> |
| O8 | Stop | NC potential-free input. If the connection between terminals O8 (Stop) and O10 (COM) is interrupted, the motor will stop. |
| O9 | Start | NO potential-free input. Closing the connection between contact O9 (Start) and O10 (COM), provided the Lock and “Stop” inputs are correctly configured, will cause the motor to start |
| O10 | COM | Common terminal for controlling inputs O7 - O9 |
| O11 | Analogue output (-) | <p>Analogue current output 0–20 mA, indicating the current motor current value. The output is scaled such that a value of 400% of the motor’s rated current corresponds to a measured current of 20 mA.</p> <p>Note: The maximum resistance value in the measuring circuit measurement circuit must not exceed 300Ω.</p> |
| O12 | Analogue output (+) | |
| O13 | RS-485 (B/-) | RS-485 communication interface output. The soft starter uses the Modbus RTU communication protocol. |
| O14 | RS-485 (A/+) | |



The **Start-Stop** function can be implemented in three-wire mode using momentary **Start** and **Stop** buttons (Fig. 8a), or in two-wire mode using a bistable **Run** switch (Fig. 8b).



a) Three-wire control

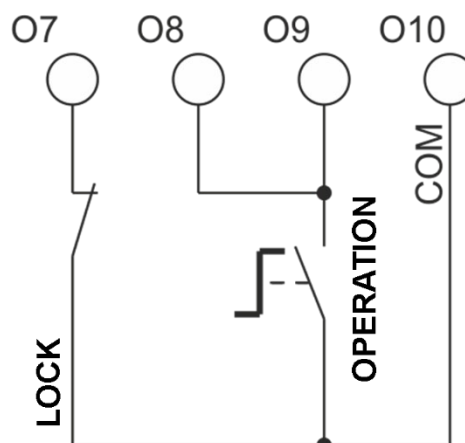

b) Two-wire control

Fig. 8: Control method

Part 4. Control panel

Description of control panel components

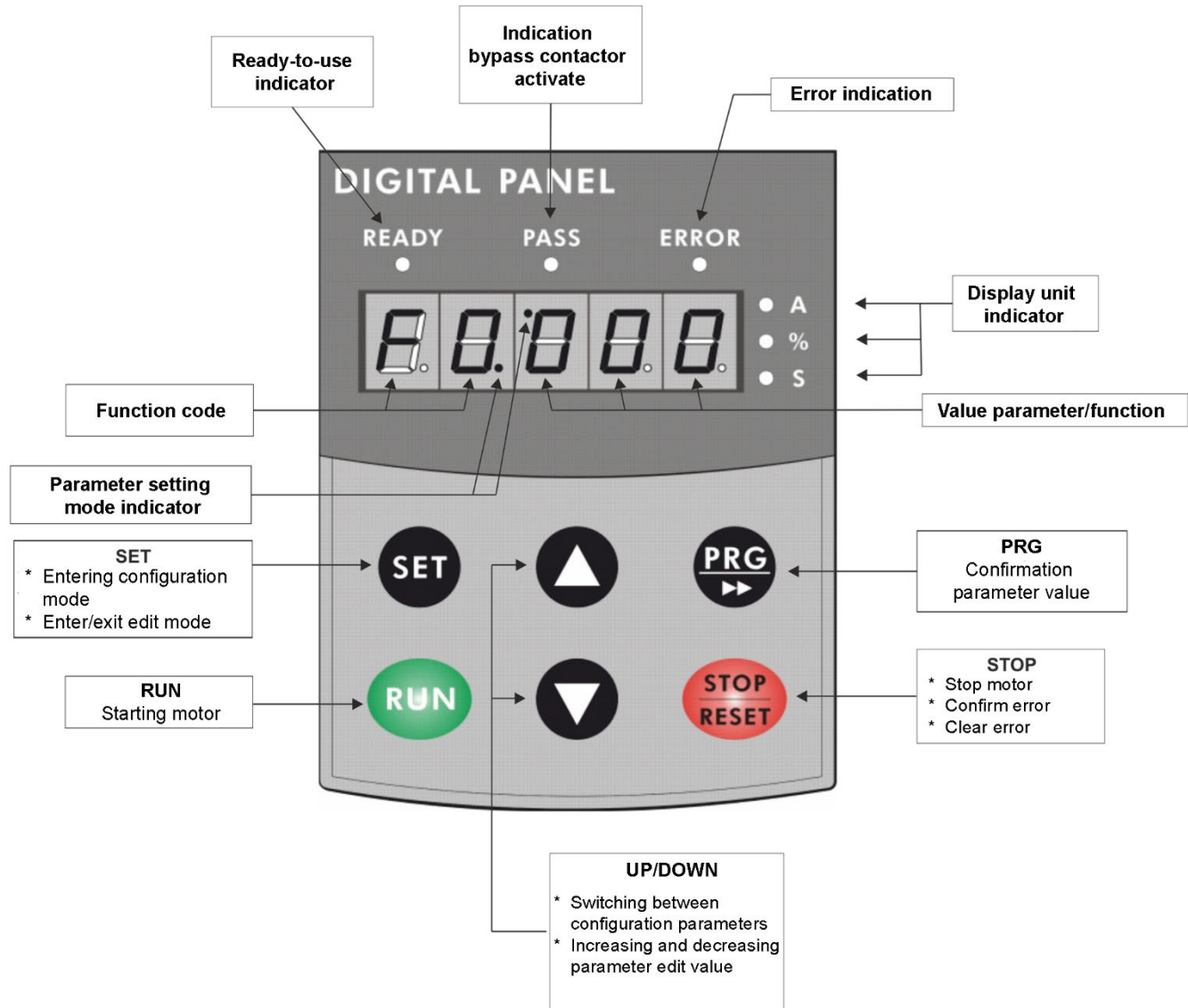



Fig. 9: Control panel

The control panel allows you to control, configure and monitor the status of the soft starter and the drive connected to it. It is divided into two main sections – the upper section containing the display and LED indicators, and the lower section with six buttons used to operate and configure the soft starter.

Once the power has been switched on and the unit has started up correctly, the soft-starter indicates that it is ready for operation by illuminating the top-left READY indicator and displaying the word 'ready' on the screen (Fig. 10). In the event of an error, the top-right ERROR indicator light will illuminate and a message with the error code will also appear on the display (Fig. 11).

| | | |
|---|---|---|
|  | <p>If an error occurs, it is essential to identify its cause (error codes can be found later in this manual). The drive may only be restarted after the cause of the error has been rectified and after the error has been acknowledged and cleared</p> |  |
|---|---|---|

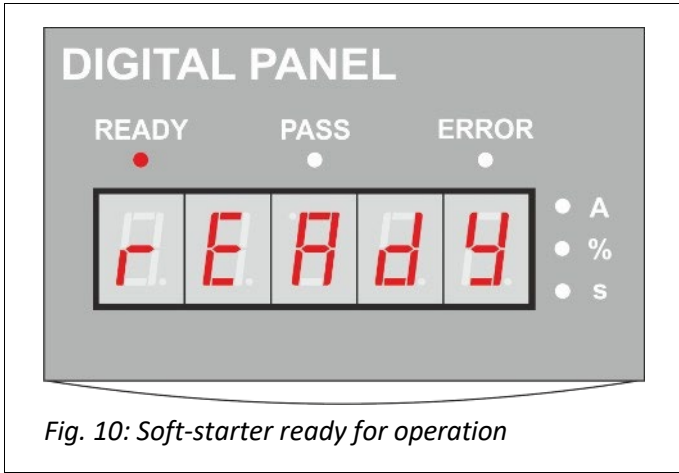

Fig. 10: Soft-starter ready for operation

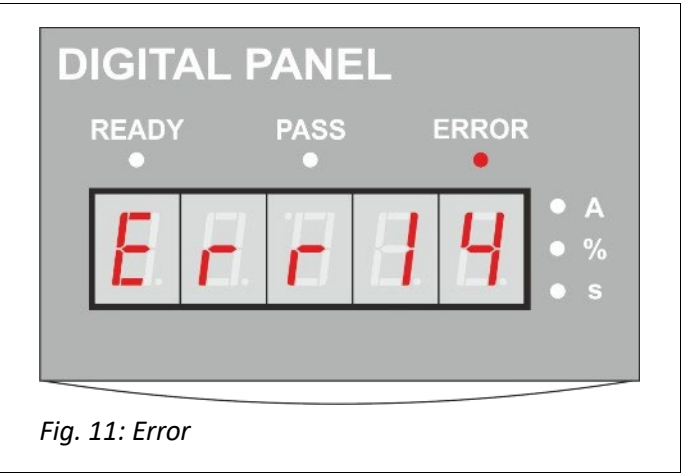

Fig. 11: Error

Monitor

During normal operation, the control panel primarily serves as a display showing the drive's operating mode and status. The following messages are displayed:

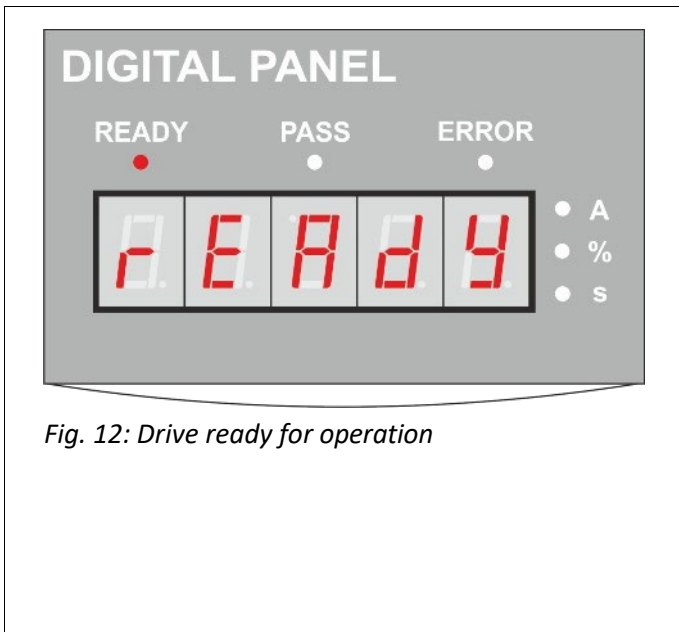

Fig. 12: Drive ready for operation

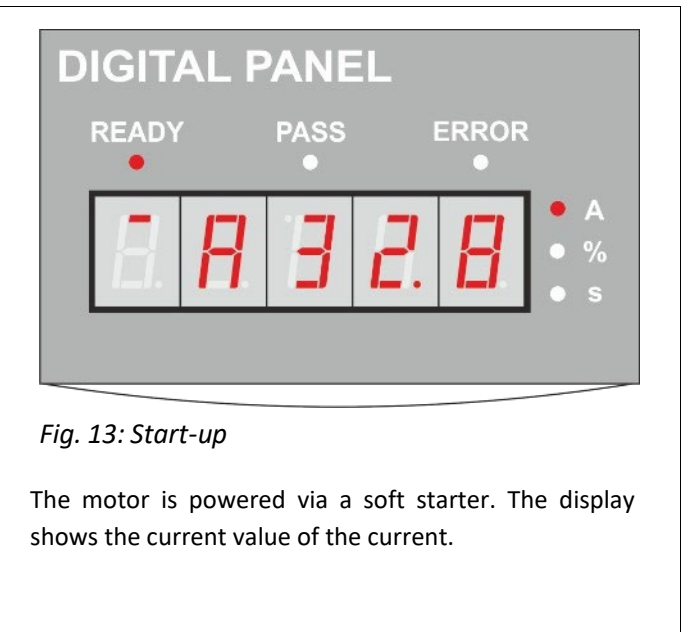

Fig. 13: Start-up

The motor is powered via a soft starter. The display shows the current value of the current.

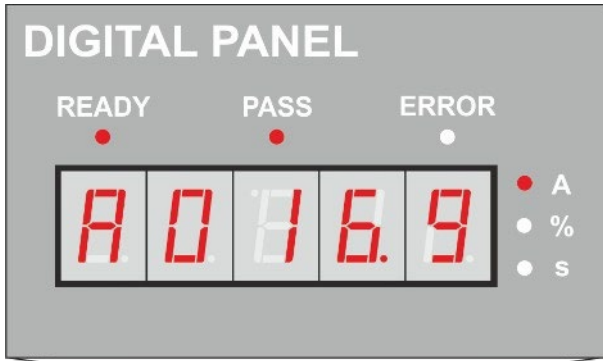

Fig. 14: Operation

The motor is powered via a bypass contactor (PASS indicator lit). The display shows the current motor current value.

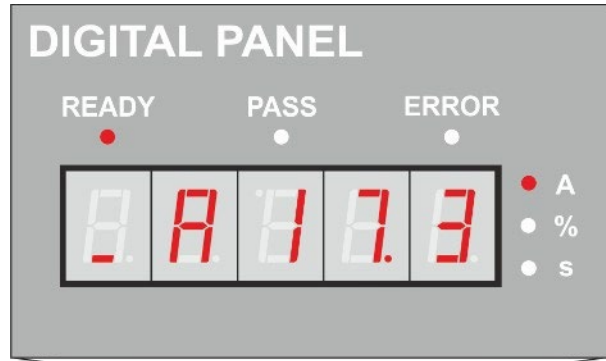

Fig. 15: Stop

The bypass contactor is switched off and braking takes place via the soft starter. The display shows the current value.

By default, the current value is shown on the display in monitor mode. Additionally, during operation (when the bypass contactor is engaged), the **Up/Down** buttons can be used to display additional information regarding the current motor power (Fig. 16) and the overload factor (Fig. 17).



The overload factor (Fig. 17) defines the ratio of the drive's current load to its rated values. If the load exceeds the rated values, this indicates a risk of the drive overheating. Depending on the duration and magnitude of the overload, this factor will increase until it reaches 100%, at which point the drive will emergency stop and an Err08 error will be reported.

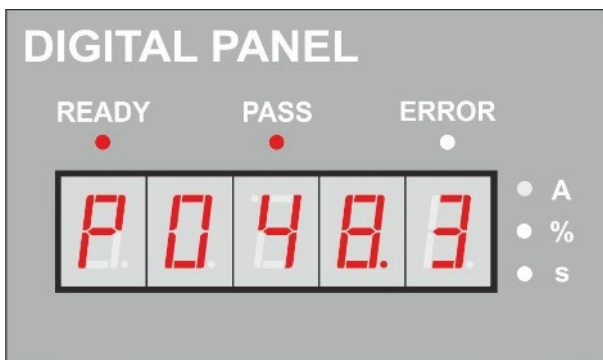

Fig. 16: Current motor power [kW]

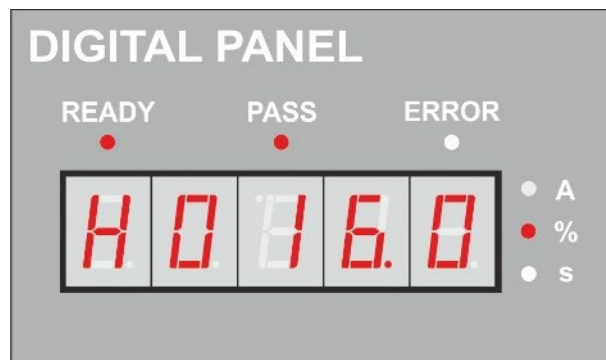

Fig. 17: Overload factor [%]

Additional information

Pressing the **PRG** button displays additional information about the device and its status. The list of parameters available here is shown in Table 2, whilst switching between parameters is done using the **Up/Down** buttons.

| Message | Description |
|---------|--|
| AC:xxx | The last three digits indicate the average phase-to-phase supply voltage of the motor |
| 022-3 | Rated soft-start power. In this case, the specification indicates a power rating of 22 kW and a three-phase supply |
| H1:E08 | List of the last nine faults recorded by the soft starter. Cell H1 displays the code of the most recent fault. The subsequent cells show earlier |
| H2:E13 | |
| | |
| H9:E00 | |
| Uer:3.0 | Software version installed in the soft starter |
| Lxxx | Number of successful drive starts |
| RUNxx | Duration (in seconds) of the last motor start |

Table 2: Additional information on the soft-starter status

Editing parameters

The diagram showing how to edit the soft-start configuration parameters is shown in Fig. 18. To enter edit mode, press the **SET** button (1). The display will show the code of the current parameter in the form Px.yyy, where x is the parameter code and yyy is the parameter value. Use the **Up/Down** buttons (2) to select the desired parameter number, then press the **SET** button (3) again. This will enter the edit mode for the selected parameter, which is indicated by the parameter edit LEDs flashing. Use the **Up/Down** buttons (4) to set the desired parameter value, then confirm the change by pressing the **PRG** button (5). Successful editing and saving is confirmed by the display of the message GO-

OD.

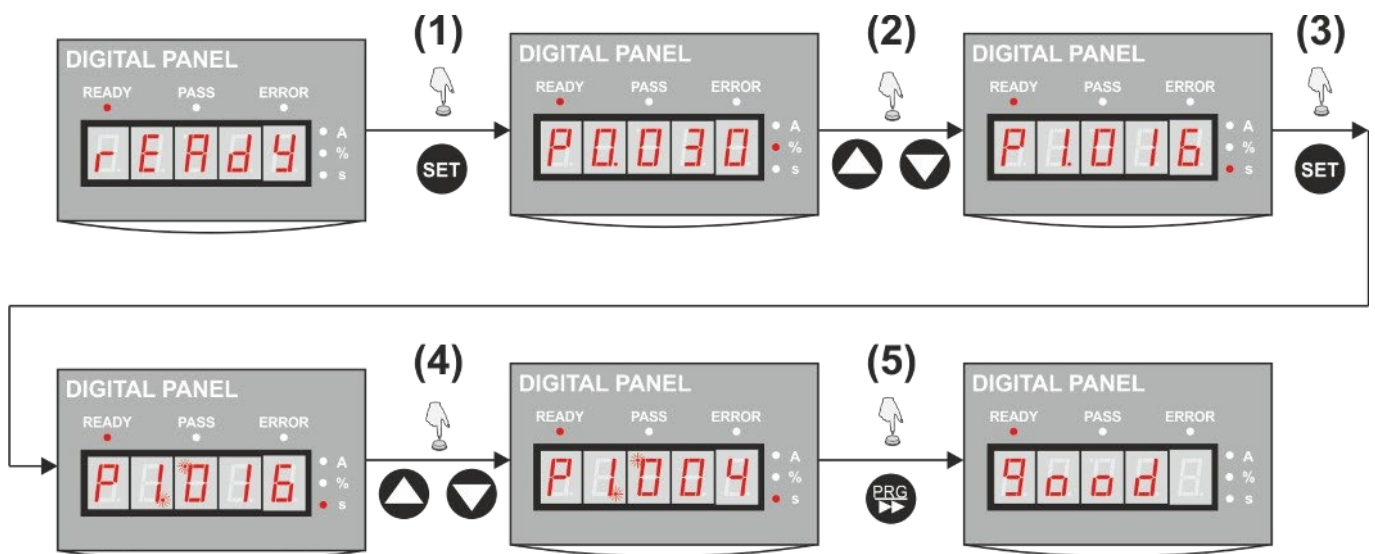

Fig. 18: Parameter editing diagram





Pressing the **SET** button in parameter edit mode will exit the edit mode for the current parameter without saving the changes made.



Part 5. Configuration





To restore the soft-start's default configuration, switch off the power to the unit, then switch it on again whilst holding down the **PRG** button.

List of parameters

| Code | Function | Description | Range Setting | Unit | Fabr. |
|------|---------------------------|--|---------------|------|-------|
| P0 | Initial voltage | The initial voltage value at which the motor is started. | 30 – 70 | % | 30 |
| P1 | Start-up time | Drive start-up time | 2 – 60 | s | 16 |
| P2 | Braking time | Method and duration of controlled drive braking 0 - Coasting >0 – Soft braking | 0 – 60 | s | 0 |
| | |  For more information on how to stop the engine, see the section 'Stopping the engine' on page 25. | | | |
| P3 | Start delay | The delay between two consecutive motor starts | 0–999 | s | 0 |
| P5 | Start-up current limit | Maximum starting current value relative to the rated current value. Applies only to starting modes based on start-up current control. | 50 – 500 | % | 280 |
| P6 | Maximum operating current | Maximum operating current of the motor . | 50–200 | % | |
| | |  If the operating current exceeds the value specified in P7, this is treated as a motor overload and, after a time depending on the extent of the excess and the load characteristics, will lead to the drive stopping and an error being reported Err08 . | | | |
| P7 | Undervoltage protection | Minimum permissible motor supply voltage relative to the rated voltage | 40 – 90 | % | 80 |
| P8 | Overvoltage protection | Maximum permissible motor supply voltage relative to the rated voltage | 100 – 140 | % | 120 |
| P9 | Start-up mode | Motor start-up mode 0. With current limit max. | 0 – 6 | - | 0 |

| Code | Function | Description | Range Setting | Unit | Factory |
|------|------------|--|---------------|------|---------|
| | | <p>of</p> <ol style="list-style-type: none"> 1. Linear voltage rise 2. Rapid start-up followed by maximum current limitation. 3. Rapid start-up followed by a linear voltage rise 4. Linear increase in current 5. Dual voltage and current control 6. Direct | | | |
| | |  Further information on start-up modes can be found in the Start-up Mode , page 20. | | | |
| PA | Protection | <p>Parameter determining the selected level of motor protection</p> <ol style="list-style-type: none"> 0. Basic – overload (thermal) protection is disabled. Short-circuit protection, power supply monitoring and soft-start overheating protection remain active. 1. Light load – Designed for drives with a light load. All protection functions are active. The thermal protection characteristic complies with class 2 2. Standard load – Designed for standard loads. All protection functions are active. The thermal protection characteristic complies with Class 10. 3. Heavy load – Designed for heavily loaded drives. The thermal protection characteristic complies with class 20. 4. Advanced – protection as for the standard setting. | 0 – 4 | - | 4 |
| | |  Further information on the available protection characteristics can be found in the Protection Characteristics section on page 27 | | | |
| PB | Control | <p>This parameter determines how the START and STOP commands can be issued to the motor. The symbol 'X' indicates that the channel in question is controlled</p> | 0 – 7 | - | 0 |

| Code | Function | Description | Range Setting | Unit | Factory | | | | | |
|--|--|---|---|-------|---------|---|---|---|---|---|
| | | is active in the selected option. The symbol “_” indicates that the control function is disabled. | | | | | | | | |
| | | Value | 0 | 1 | 2 | 3 | 4 | 5 | 6 | 7 |
| | | Control panel | X | X | - | - | X | X | - | - |
| | | Terminals | - | X | X | X | X | - | - | - |
| | | RS485 | - | - | - | X | X | X | X | - |
| PC | Settings lock | Lock on parameter setting changes: | | | | | | | | |
| | | 0 | The ability to change of any parameter | 0 – 2 | - | 0 | | | | |
| | | 1 | The ability to change the settings for parameters 4, P6, PD, is disabled PE, PP, PU | | | | | | | |
| 2 | No restrictions – full flexibility to change all settings settings | | | | | | | | | |
| PD | Address | Device address in the communication network | 0 – 64 | - | 0 | | | | | |
| PE | OUT programmable output function | The codes in the unit positions specify the output function. 0 in the tens place indicates a NO output, 1 in the tens place indicates an NC output. | 0 – 19 | - | 7 | | | | | |
| | | Function codes: 0) Ready for operation 1) Motor start 2) Bypass contactor activation 3) Start of braking 4) Motor stop | | | | | | | | |
| | |  Functions with codes 0–4 are momentary functions that activate the relay for approx. 1 s. Additionally, parameter P4 can be used to introduce a delay between the occurrence of the event and the activation of the relay | | | | | | | | |
| | | 5) Fault – Drive lockout 6) Operating 7) Ready for operation 8) Motor start-up 9) Bypass contactor activation | | | | | | | | |
|  Functions with codes 5–9 are state functions. This means that the relay remains active for as long as the triggering event persists. In this mode, it is not possible to... P4 delay control. | | | | | | | | | | |

| Code | Function | Description | Range Setting | Unit | Fabr. |
|------|--|---|---------------|------|-------|
| PF | Braking – maximum current | Limitation of the maximum current during controlled motor braking | 20 – 100 | % | 80 |
| PP | Rated motor current | Rated motor current. Enter the current value read from the motor nameplate | - | A | - |
| PU | Bypass contactor delay bypass | Delay on contactor engagement 0 – 400 ms | 0 – 40 | s | 3 |
| EN | Voltage asymmetry control control | 0 – enabled 1 – disabled | 0 – 1 | - | 1 |
| P4 | Current reading scaling – | Factors for calibrating the readings of measured voltage and current values | 50 – 150 | % | 100 |
| P3 | Scaling of the voltage reading voltage | | 50–150 | % | 100 |

Start-up mode

Maximum current limitation

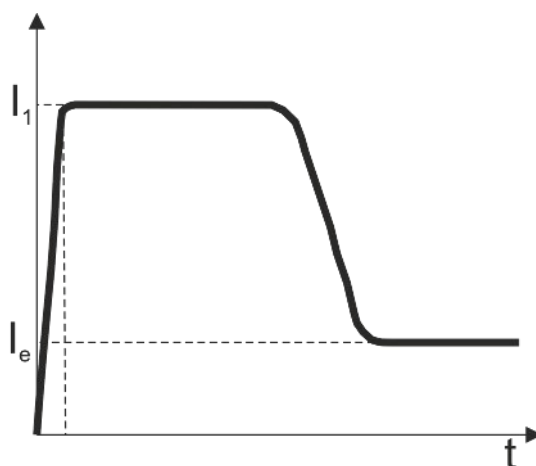

Fig. 19: Start-up with maximum current limitation

During start-up in maximum current limit mode, the motor supply voltage is increased until the start-up current limit I_1 (parameter P6) is reached. The soft starter then continues to accelerate the motor whilst monitoring that the current does not exceed the maximum value. Once the motor has accelerated, the current drops to the nominal value (or lower) and the bypass contactor is then switched on, completing the motor start-up procedure.



The initial motor supply voltage is always 40%, regardless of the setting of parameter P0

In the case of drives with a light load, or a high current setting I, it may happen that during start-up, the maximum starting current will not be reached. In this case, the start-up time will be very short, and the behaviour will be similar to that of connecting the motor directly to the mains.

Linear voltage ramp-up

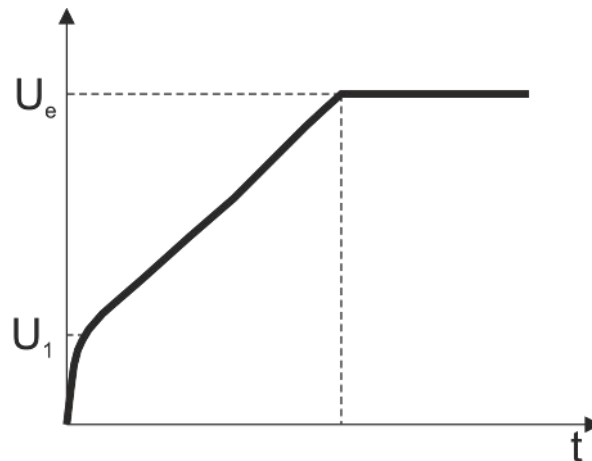

Fig. 20: Start-up with linear voltage rise

In this case, after start-up, the voltage rises rapidly to the value U (defined in parameter P1), and then gradually rises to the rated value. Once the rated voltage is reached, the bypass contactor is engaged and the start-up procedure is completed.



For start-up with a set voltage ramp, the overcurrent protection level is set by default to 400% – the option to modify this value by changing parameter P6 is disabled.



The motor start-up time depends more on the nature of the load and the start-up process than on the set start-up time (parameter P1). If the motor load is not high and the start-up proceeds without disruption, the full start-up time may be shorter than that indicated by the setting of parameter P1.

Soft start and current limiting

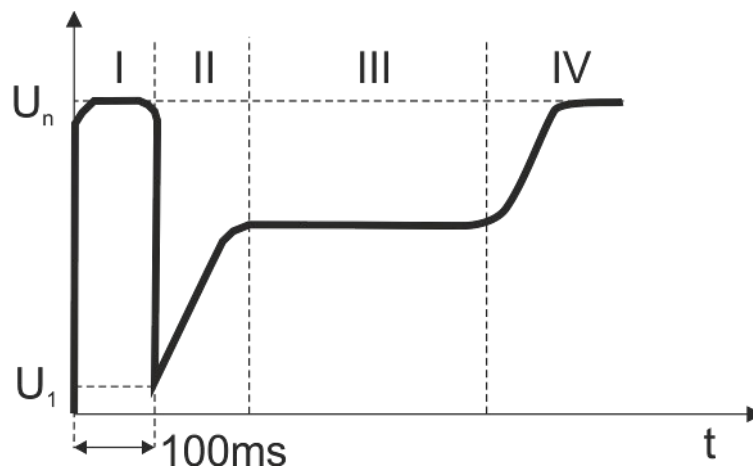





Fig. 21: Soft start and current limiting

A soft start is designed for drives where there is high static friction and conventional starting methods do not provide sufficient torque to start the motor. In this case, once the drive is activated, the voltage is applied at the rated value for 100 ms (I). After this time, the voltage drops (II) to value U (parameter P1), and then rises until the limit value is reached (parameter P6). Soft-

The starter continues to accelerate the motor (III) whilst ensuring that the current does not exceed the limit value. Once the motor has accelerated and reached the rated voltage (IV), the bypass contactor is engaged and the starting procedure is completed.

-  Due to the high mechanical and electrical shock involved, the soft-start solution should only be used in cases where the conventional starting method fails (e.g. in cases of high static friction).
-  When starting with a preset voltage ramp, the overcurrent protection level is set to 400% by default – the option to modify this value by changing parameter P6 is disabled.
-  The actual motor start-up time depends mainly on the nature of the load and the start-up process. If the motor load is not high and the start-up proceeds without disruption, the full start-up time may be shorter than indicated by the setting of parameter P1.

Soft start and linear voltage rise

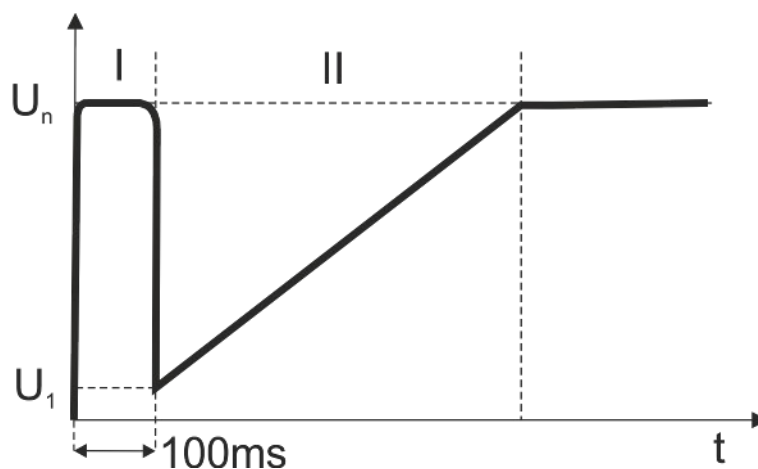

Fig. 22: Rapid start and linear voltage rise

A soft start is designed for drives where there is high static friction and conventional starting methods do not provide sufficient torque to start the motor. In this case, once the drive is activated, the voltage is applied at the rated value for 100 ms (I). After this time, the voltage drops (II) to value U (parameter P1), and then rises linearly (II) until the rated value is reached. After the motor has accelerated and reached the rated voltage, the bypass contactor is engaged and the start-up procedure is completed.



Due to the high mechanical and electrical shock involved, the rapid start-up method should only be used when the standard start-up method fails (e.g. in cases of high static friction).



When starting with a set voltage ramp, the overcurrent protection level is set by default to 400% – the option to modify this value by changing parameter P6 is disabled.



The actual motor start-up time depends mainly on the nature of the load and the start-up process. If the motor load is not high and the start-up proceeds without disruption, the full start-up time may be shorter than indicated by the setting of parameter P1.

Linear current rise

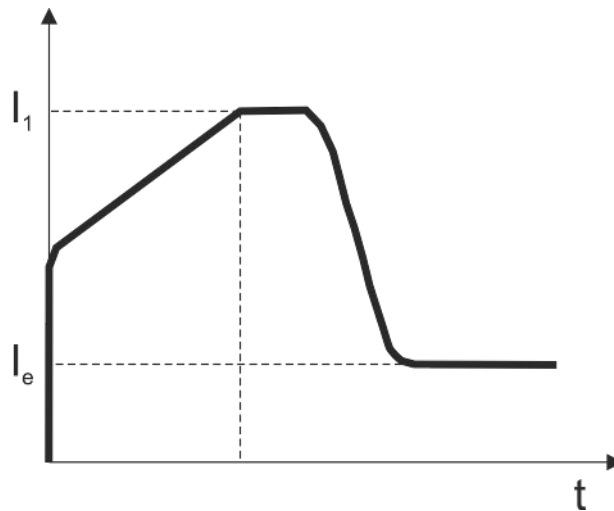

Fig. 23: Linear current rise

In the case of a start-up with a linear current ramp-up, a voltage equal to 40% of the rated value is applied to the motor when the drive is activated. The voltage then changes in such a way as to ensure a linear current rise until the maximum value I , defined in parameter P6, is reached. Afterwards the drive continues to accelerate, with the system preventing the maximum value from being exceeded. Once the motor has accelerated, the current drops to the rated value and the bypass contactor is engaged.

Dual voltage and current control

Double-loop voltage feedback starting combines the methods of linear voltage ramp-up and linear current ramp-up. By using advanced prediction algorithms, the soft-start control system attempts to model the motor and, on this basis, automatically generate the optimal starting characteristic.

Direct start with parameter control

In direct start mode, the soft starter supplies the motor with full voltage whilst simultaneously monitoring the current and other electrical parameters. If an overload, under-voltage or over-voltage is detected, alarm contacts 5-6 are opened, enabling, for example, the drive power supply to be cut off.

Motor stopping

The motor can be switched off in two ways, depending on the setting of parameter P2



| | | |
|--------|--|---|
| P2 = 0 | <p>Coast-to-stop</p> <p>If parameter P2 is set to 0, the bypass contactor will be disconnected when the STOP command is issued and the motor will coast to a stop. The soft starter will not affect the braking characteristics in any way.</p> | |
| |  | <p>Coast-down braking is the preferred method of stopping the motor and significantly extends the service life of the soft starter.</p> |
| P2 > 0 | <p>Soft braking</p> <p>If parameter P2 is set to a value greater than zero, then upon issuing the STOP command, the bypass contactor will be disconnected, whilst full voltage is applied to the motor via the soft starter's internal circuits. The supply voltage will then be gradually reduced until the motor comes to a complete stop.</p> <p>Soft braking can be used to eliminate water hammer in pump systems. However, due to the possibility of high currents flowing from the motor back to the mains during braking, this solution is recommended only for drives with relatively low inertia.</p> <p>Parameter P2 specifies the braking time in seconds, although the actual stopping time will depend more on the load parameters than on this value. In the case of light drives with low inertia, stopping may occur significantly faster than indicated from the P2 settings.</p> | |

Table 3: Motor stopping method

Protections

The soft starter is equipped with a range of safety features designed to provide effective protection for both the soft starter itself and the motor it powers. It is the user's responsibility to configure the safety settings, taking into account the load characteristics and operating conditions.

List of safety features

| Protection | Description |
|--------------------------|--|
| Temperature | If the soft starter's temperature exceeds 80°C (± 5°C), the drive will stop and the ability to restart will be blocked until the temperature drops below 55°C. |
| Phase voltage loss | In the event of a power failure on any of the input phases lasting less than 3 seconds, the drive will stop and the soft start will be blocked. |
| Phase current asymmetry | If the phase current asymmetry of the motor exceeds 50% (± 10%), the motor will stop and the soft start will be blocked within <3 seconds. |
| Overcurrent protection | The response time of the overcurrent protection will depend on the set operating current value (P7) and the selected protection characteristic (P6). Further information can be found in |
| Thermal protection | The protection is based on a simulation of the motor's thermal model. The response time depends on the set base current value (P7) and the selected protection characteristic (P6). Further information can be found in |
| Oversvoltage protection | If the supply voltage exceeds 140% of the rated value, tripping will occur within < 0.5s. If the voltage is lower than 140% of the rated value but higher than the PA protection level, tripping will occur within less than 0.5s |
| Undersvoltage protection | If the supply voltage is lower than 40% of the rated value, tripping will occur within < 0.5 s. If the voltage is higher than 40% of the rated value and lower than the P9 protection level, tripping will occur within < 3 s |
| Short-circuit protection | If the motor current exceeds 10 times the rated current, tripping will occur within < 0.1 s |
| |  <p>The short-circuit protection built into the soft starter can only serve as an additional protection measure. In all cases, additional overload protection is essential.</p> |
| Underload protection | Depending on the set value of the PU parameter, the protection can be set to a level of 20–90% of the rated current, and the response time of the protection to a level of 10–90 s |

Protection characteristics

| PC parameter | Basic | Light load | | | Standard load | | | Heavy load | | | Advanced | | |
|-------------------------------|-------|------------|-----|-----|---------------|----|-----|------------|----|----|----------|----|-----|
| Thermal protection class | None | 2 | | | 10 | | | 20 | | | 10 | | |
| Overcurrent control delay [s] | None | 3 | | | 15 | | | 30 | | | 15 | | |
| Thermal protection trip time | I/le | 3 | 4 | 5 | 3 | 4 | 5 | 3 | 4 | 5 | 3 | 4 | 5 |
| | Delay | 4.5 | 2.3 | 1.5 | 23 | 12 | 7.5 | 46 | 23 | 15 | 23 | 12 | 7.5 |

The characteristics and thermal protection classes comply with standard IEC 60947-4-2 and are shown in Fig. 24.

Correct selection of the protection level is crucial for ensuring the protection of the soft starter and the motor. Care must be taken to ensure the correct setting of the motor rated current (parameter PP), the maximum permissible operating current (parameter P7), and the protection characteristics (parameter PC).

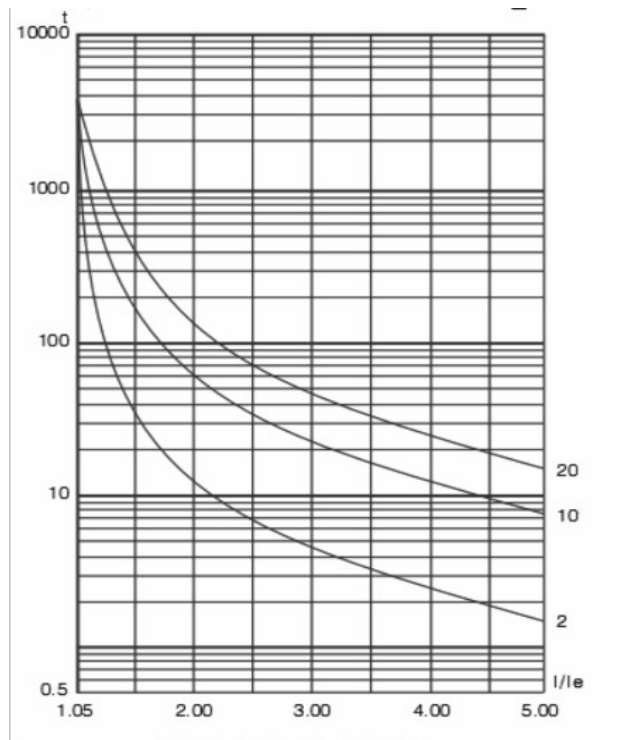

Fig. 24: Thermal protection characteristics

Part 6 – RS-485 communication

The SF series soft starters are equipped with an RS-485 interface supporting the Modbus RTU communication protocol. This interface enables direct control, configuration and monitoring of the device's status.

Communication parameters

| | |
|---------------------|----------|
| Speed | 9600 bps |
| Number of data bits | 8 |

| | |
|---------------------|----------------------------------|
| Number of stop bits | 1 |
| Parity check | None |
| Address | 0 – 60 (set by the PD parameter) |

List of registers

| Register | | Command code | Description | |
|----------|-------|--------------|--|-----------|
| DEC | HEX | | | |
| 1 | 0x01 | 06 | Control. Settings: 1 – Start 2 – Stop 4 – Reset | |
| 2 | 0x02 | 03 | Status | |
| | | | Bit 0 | Start-up |
| | | | Bit 1 | Operating |
| | | | Bit 2 | Stop |
| 3 | 0x03 | 03 | Average effective current value | |
| 4 | 0x04 | 03 | Error code | |
| 256 | 0x100 | 03/06 | Configuration | P0 |
| 257 | 0x101 | | | P1 |
| 258 | 0x102 | | | P2 |
| 259 | 0x103 | | | P3 |
| 260 | 0x104 | | | P4 |
| 261 | 0x105 | | | P5 |
| 262 | 0x106 | | | P6 |
| 263 | 0x107 | | | P7 |
| 264 | 0x108 | | | P8 |
| 265 | 0x109 | | | P9 |
| 266 | 0x10A | | | PA |
| 267 | 0x10B | | | PB |

| | | | | |
|-----|-------|--|--|----|
| 268 | 0x10C | | | PC |
| 269 | 0x10D | | | PD |
| 270 | 0x10E | | | PE |
| 271 | 0x10F | | | PF |
| 272 | 0x110 | | | PP |
| 273 | 0x111 | | | PU |
| 274 | 0x112 | | | PL |

Part 7 – Detection Create and Fault detection delete

Fault codes

| Error code | Fault name | Name | Fault description and how to rectify it |
|------------|------------------------------|-----------------|---|
| Err00 | Cause | Fault rectified | This occurs when the cause of the soft-start lockout has been automatically resolved. This applies only to faults relating to excessively low supply voltage, excessively high supply voltage, soft-start overheating, or a temporary breach of the interlock chain. In such cases, the fault must be acknowledged by pressing the STOP/RESET button and the drive can be restarted. |
| Err01 | Interruptio interlo | interlock | The connection between terminals O7 and O10 has been interrupted. Identify and rectify the cause of the interlock chain violation. Then clear the error using the STOP/RESET button and restart the drive. |
| Err02 | Overheat of soft starter ing | of soft starter | The maximum permissible temperature of the soft starter has been exceeded. This may be caused by, among other things, too frequent starts, the unit's power being insufficient for the connected motor, or the ambient temperature of the soft starter being too high. Diagnose and eliminate the cause of the temperature exceeding the limit. Once the module's temperature has dropped to a safe level, you can clear the error and restart start the motor. |
| Err03 | Start-up time too long | start-up | The motor start-up time has exceeded 60 seconds. This may indicate incorrectly selected start-up parameters, excessive motor load, or that the soft starter's power rating is not matched to the motor's power rating. Diagnose and rectify the cause of the fault, then clear Press the STOP/RESET button to clear the error and restart the motor. |
| Err04 | Phase loss | phase loss | No voltage on one of the supply phases. Check the correctness of the connections and the operation of the input contactor K1 and fuse F1. Once the fault has been rectified and the error cleared, you can restart restart the motor. |

| | | |
|---|---|--|
| Err05 | Output voltage loss | No voltage on one of the phases at the motor terminals. Check the correctness of the connections and the operation of the bypass relay. If the connections are correct and the error occurs during motor start-up/stop – contact the service department. In other cases, after rectifying the fault and clearing the error, you can restart the motor. |
| Err06 | Supply voltage asymmetry | There is excessive asymmetry between the voltages on the individual phases. Check the quality of the supply line and the correctness of the connections. After rectifying the fault and clearing the error, you can restart the motor. |
| Err07 | Overload during start-up | The current limit was exceeded during motor start-up. Check the soft-start settings and ensure that the unit's power rating is suitable for the connected motor and load. Once the fault has been rectified and the error cleared, the motor can be restarted |
| Err08 | Overload during operation | Excessive load during operation. First, check whether the soft-start parameters (PP and P7) are adjusted to the actual load. Additionally, check whether the load on the motor shaft does not exceed the rated power of the motor or the soft-start unit. Once the fault has been rectified and the error cleared, the motor can be restarted the motor. |
| Err09 | Supply voltage too low Check | Check the setting of parameter P9 and the actual value of the supply voltage. |
| Err10 | Supply voltage too high supply voltage | Check the setting of parameter P9 and the actual value of the the supply voltage. |
| Err11 | Configuration error | Incorrect soft-start configuration. Where possible, identify and correct the incorrect entry. If this is not possible, restore the device's default configuration |
| | |  To restore the soft start's default configuration, switch off the power to the device, then switch it back on whilst holding down the PRG button. |
| Err12 | Short circuit | Sudden current surge. This may be caused by an excessive load or a motor jam. The soft starter may also be faulty. |
| Err13 | Automatic start configuration error. | The soft starter has been configured to operate in automatic start mode, but the input signals are not suitable for operation in this mode. Please check whether the external control is correctly in accordance with the two-wire configuration. |
| Err14 | STOP input error | If the STOP button is pressed, the drive cannot be started |
| Err15 | Load too low | The motor load during operation is lower than the value set in the PU parameter. |
| Some error messages may be interrelated. For example, error Err02 , indicating motor overheating, may be caused by high temperature resulting from both high load current and a short circuit. | | |

Device specifications

| Type | SF-110 | SF-150 | SF-180 | SF-220 | SF-300 | SF-370 | SF-450 | SF-550 |
|--------------------|--|--------|--------|--------|--------|--------|--------|--------|
| Power supply | Three-phase, 3x400V (± 15%), frequency 50Hz | | | | | | | |
| Motor | Three-phase asynchronous motor (400 V windings) | | | | | | | |
| Output power [kW] | 11 | 15 | 18 | 22 | 30 | 37 | 45 | 55 |
| Output current [A] | 22 | 30 | 37 | 44 | 60 | 74 | 90 | 110 |
| Motor control | Start-up and braking – control of all three output phases Operation – external bypass contactor required | | | | | | | |
| Start-up | <ol style="list-style-type: none"> 1) With maximum current limitation 2) Linear voltage ramp-up 3) Rapid start-up followed by maximum current limitation. 4) Rapid start followed by a linear voltage rise 5) Linear current rise 6) Dual voltage and current control 7) Direct with parameter control | | | | | | | |
| Braking | <ol style="list-style-type: none"> 1) Soft braking 2) Coast braking | | | | | | | |
| Protections | <ol style="list-style-type: none"> 1) Soft start temperature protection 2) Phase voltage loss 3) Motor thermal protection 4) Overvoltage and undervoltage 5) Short-circuit | | | | | | | |
| Inputs | Potential-free control relative to COM <ol style="list-style-type: none"> 1) Start 2) Stop 3) Interlock | | | | | | | |
| Relay outputs | <ol style="list-style-type: none"> 1) Bypass contactor power supply 2) Error indication 3) Programmable – available functions: <ul style="list-style-type: none"> - Ready for operation - Motor start - Bypass contactor activation - Start of braking - Motor stop - Fault – Drive lock - Running - Ready for operation | | | | | | | |

| | | |
|----------------------|---|--|
| | <ul style="list-style-type: none"> - Motor start-up - Bypass contactor activation | |
| Analogue output | Current signal (0–20 mA) proportional to the current motor current. | |
| Communication | RS485 communication interface with Modbus RTU protocol support | |
| Control panel | <p>1) Four-digit LCD display and LED indicators enabling:</p> <ul style="list-style-type: none"> - soft-start programming - operating status indication - display of information on current, power and motor overload - display of error messages <p>2) Keypad for motor control and soft start configuration</p> <p>3) Option to lock or restrict changes to settings.</p> | |
| Operating conditions | Operating environment | <ul style="list-style-type: none"> - Free from dust and particulates (particularly conductive ones) - Ensuring proper ventilation of the device - Protected against unauthorised access |
| | Temperature | - 25.. + 40°C |
| | Humidity | Below 90% (non-condensing) |
| | Vibration | Less than 0.5G |
| | Operating altitude | Below 3,000 m above sea level |

Warranty

1. The Softstart is covered by a 24-month warranty. The warranty period begins on the date of purchase.
2. The warranty is valid only with proof of purchase.
3. Complaints should be made at the point of purchase or directly to the manufacturer:

F&F Filipowski sp. k.
79/81 Konstytucyjna Street
95-200 Pabianice
Tel. (42) 227-09 71
Email: dztech@fif.com.pl

4. A written description of the nature of the fault and the circumstances in which it occurred must be attached to the complaint.
5. F&F Filipowski sp. j. undertakes to handle complaints in accordance with the provisions of Polish law.
6. The choice of how to resolve the complaint – replacement with a fault-free item, repair or a refund – is at the manufacturer’s discretion.
7. The warranty does not cover:
 - a. Mechanical and chemical damage
 - b. Damage resulting from improper use or use not in accordance with the user manual
 - c. Damage occurring after sale as a result of accidents or other events for which neither the manufacturer nor the point of sale is responsible, e.g. damage during transport.
8. The warranty does not cover actions which, according to the instructions, should be carried out by the user, e.g. connecting the device, carrying out electrical installation, or installing other required electrical safety measures.
9. The warranty does not limit the buyer’s rights arising from the non-conformity of the goods with the contract.