



08/2022

Technical application guide

OSRAM BT Control

New feature: Configuration of multiple devices

Light is OSRAM

OSRAM

Contents

1 Introduction	03
1.1 The principle	03
2 General information	04
2.1 BT Control devices	04
2.1.1 Wiring diagrams	05
2.2 Apps	06
2.3 Connectable devices	06
2.3.1 OSRAM DALI sensors and couplers G2 – DALI-2-certified	07
2.3.2 OSRAM DALI pushbutton coupler G2 – function modes	08
2.3.3 Limitations on connectable devices	08
2.4 General installation instructions	09
2.4.1 Safety instructions	09
2.4.2 Wiring instructions	09
2.4.3 Radio optimization	10
2.4.4 Light sensor placement and set point for light regulation	13
3 Control features	14
3.1 Standard features (available without app)	14
3.2 Advanced features (available with app)	14
3.2.1 Tunable White	15
3.2.2 Group control	15
3.2.3 Swarm feature	15
3.3 Special features of DALI ECO BT RTC	15
3.3.1 Human Centric Lighting (HCL)	16
3.3.2 Timer	16
3.4 Demo mode	17
4 Configuration of multiple devices	18
4.1 Overview	18
4.2 Three steps for luminaire production with BT Control products	19
4.2.1 Step 1: Commissioning of a reference luminaire	19
4.2.2 Step 2: Upload the configuration to multiple BT Control products	20
4.2.3 Step 3: Assembly of the luminaire in production	22
5 Applications and settings	23
5.1 Stand-alone luminaires with integrated BT Control	23
5.1.1 Floor-standing luminaire with 1 x DALI LED driver (with out-of-the-box light functions)	23
5.1.2 Floor-standing luminaire with 2 x DALI LED drivers separating the direct and indirect light	27
5.1.3 Floor-standing luminaire with 1 x DALI LED driver and active HCL function	31
5.2 Single-room applications with integrated BT Control	34
5.2.1 Single office (with out-of-the-box light functions)	34
5.2.2 Meeting room with scene control	38
5.2.3 Classroom with daylight harvesting (DLHV) plus light group offset	41
5.2.4 Corridor including standby (infinite timer)	45
5.2.5 Open-plan office including standby	47
5.2.6 Open-plan office including Swarm function	51
5.2.7 Open-plan office including Swarm function and zone division	54

1 Introduction

The OSRAM BT Control System represents a new generation of intelligent, independently operating light control systems. In spite of their compact dimensions, the components of the system are extremely powerful. No matter if the light is controlled manually by pushbuttons or by fully automatic presence and daylight operation, the OSRAM BT Control System can always be used in a flexible manner. Compared to conventional, purely switchable solutions, energy savings up to 80 % can be achieved while enjoying a significantly higher lighting comfort.

OSRAM BT Control devices are suitable especially for lighting control at single or group workplaces, corridors, classrooms or sanitary rooms. Through the integrated Bluetooth Low Energy (BLE) radio module, it is possible to control the light via an iOS or Android smart phone by the OSRAM BT Control App or to modify the control profile by the OSRAM BT Config App. Access via Bluetooth (BT) can be restricted via password. This guide will show you the most important features and provide you with troubleshooting instructions.

1.1 The principle

The DALI ECO BT, DALI ECO BT RTC or DALI ACU BT Control device is the central element of the system (application controller). Based on signals coming from sensors and manual user interfaces, it controls the light level of connected luminaires according to the chosen function mode and its individual parameterization. The integrated software-based regulation algorithms and timers allow an automatic change and optimization of the lighting level.

All settings can be read out and modified by the OSRAM BT Config App. Existing configurations can either be overwritten completely via profile upload, or only changed by modifying individual parameters.

OSRAM BT Control devices can be adapted in a modular way according to the application requirements or application size. Thanks to its plug-and-play capability, the control unit starts to detect and configure connected DALI components automatically after power-up. Hot-plugging of DALI devices after power-up is not recommended and may lead to an unwanted behavior.

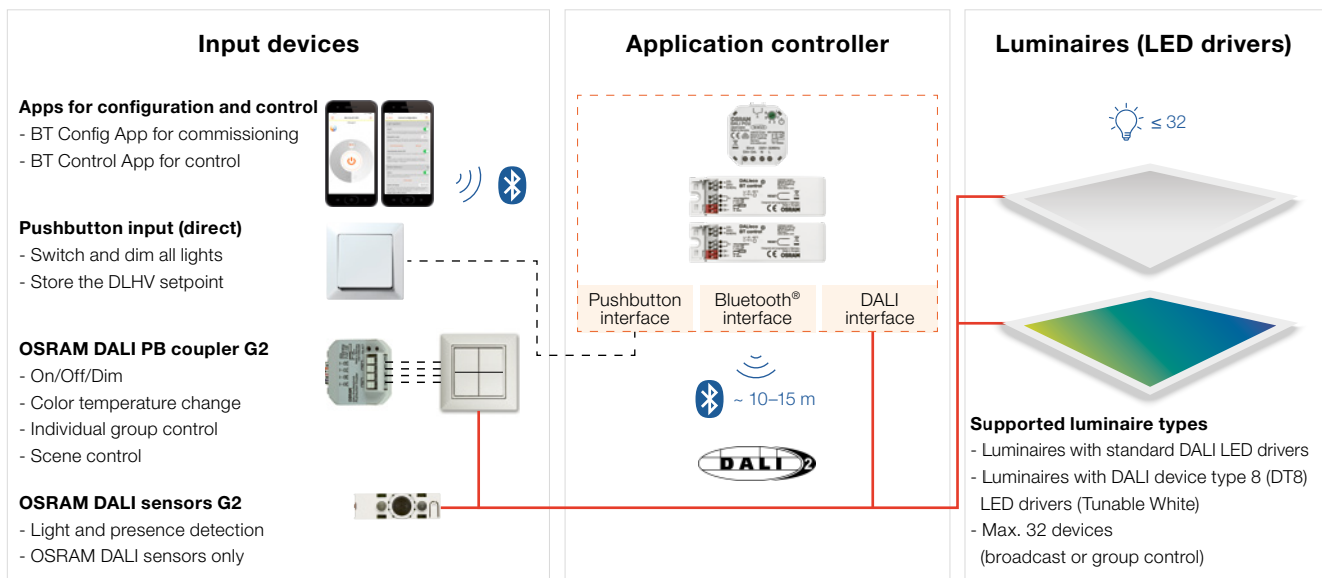

2 General information

OSRAM BT Control devices are DALI lighting controls with a Bluetooth Low Energy (BLE) interface. All OSRAM BT Control devices are powerful stand-alone units which can be configured and controlled with a smart device.

2.1 BT Control devices

Three hardware types of OSRAM BT Control devices are available:

- DALI ACU BT
- DALI ECO BT
- DALI ECO BT RTC (with integrated real-time clock)



Control features

Plug-&-play, out-of-the-box features	Yes	Yes	Yes
Control and configuration via app (Android/iOS)	Yes	Yes	Yes
Support of OSRAM DALI and DALI-2 sensors and couplers	Yes	Yes	Yes
No. of different connectable pushbuttons	1	1	2 ¹⁾
DALI grouping	Yes (up to 4)	Yes (up to 4)	Yes (up to 4)
Swarm function (wireless interconnection between controllers)	Yes	Yes	Yes
Mounting type	Flush box	Luminaire integration ²⁾	Luminaire integration ²⁾
HCL function (automatic daytime-based color temperature change)	-	-	Yes
Timer functions	-	-	4

1) Second pushbutton needs a resistor in the daisy chain

2) False ceiling integration with cable clamp (ECO CI Kit) possible

All three hardware types of OSRAM BT Control devices feature the same electrical parameters:

Electrical parameters	Value
V_{AC}	220-240 V; 50/60 Hz
P	0.3-3 W
t_a	-20 ... +60 °C
IP rating	IP20
Max. DALI load	32 ECGs + 4 OSRAM DALI sensors or DALI pushbutton couplers
	96 mA

2.1.1 Wiring diagrams

DALI ACU BT

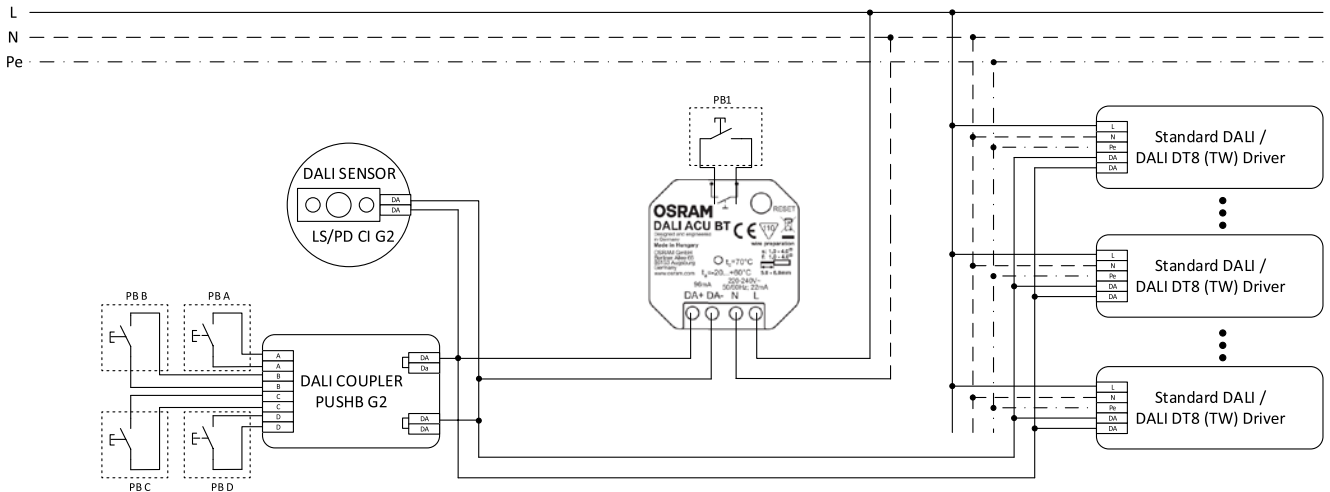

DALI ECO BT

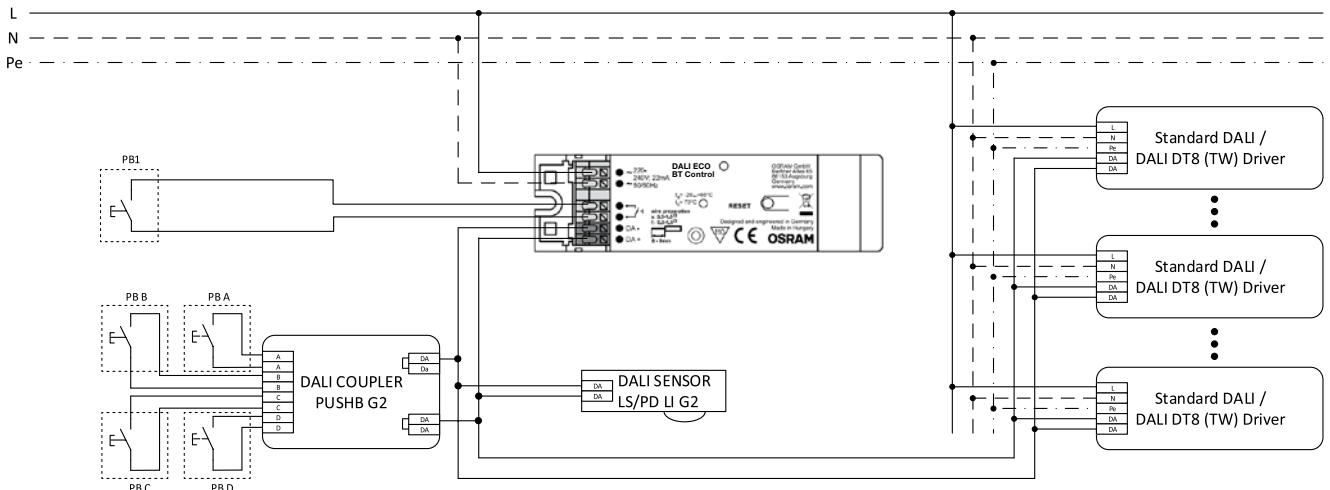

DALI ECO BT RTC

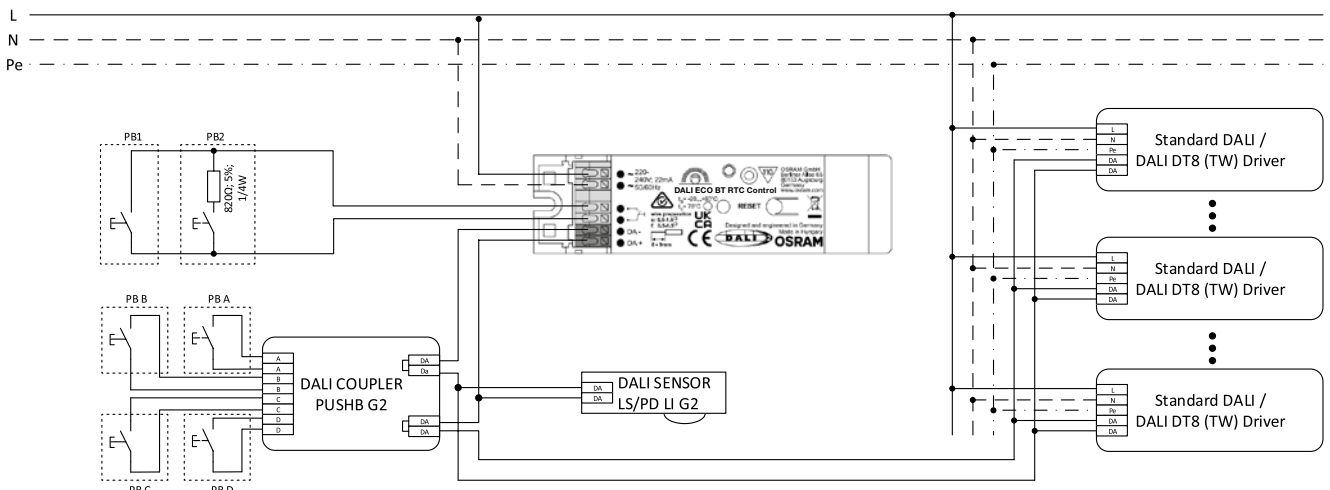

2.2 Apps

OSRAM BT CONTROL APP



For system control functions
(end-user app)



IOS - OSRAM
BT Control App



Google - OSRAM
BT Control App



IOS - OSRAM
BT Config App



Google - OSRAM
BT Config App

OSRAM BT CONFIG APP



For system configuration and control
(installer/system manager app)

2.3 Connectable devices

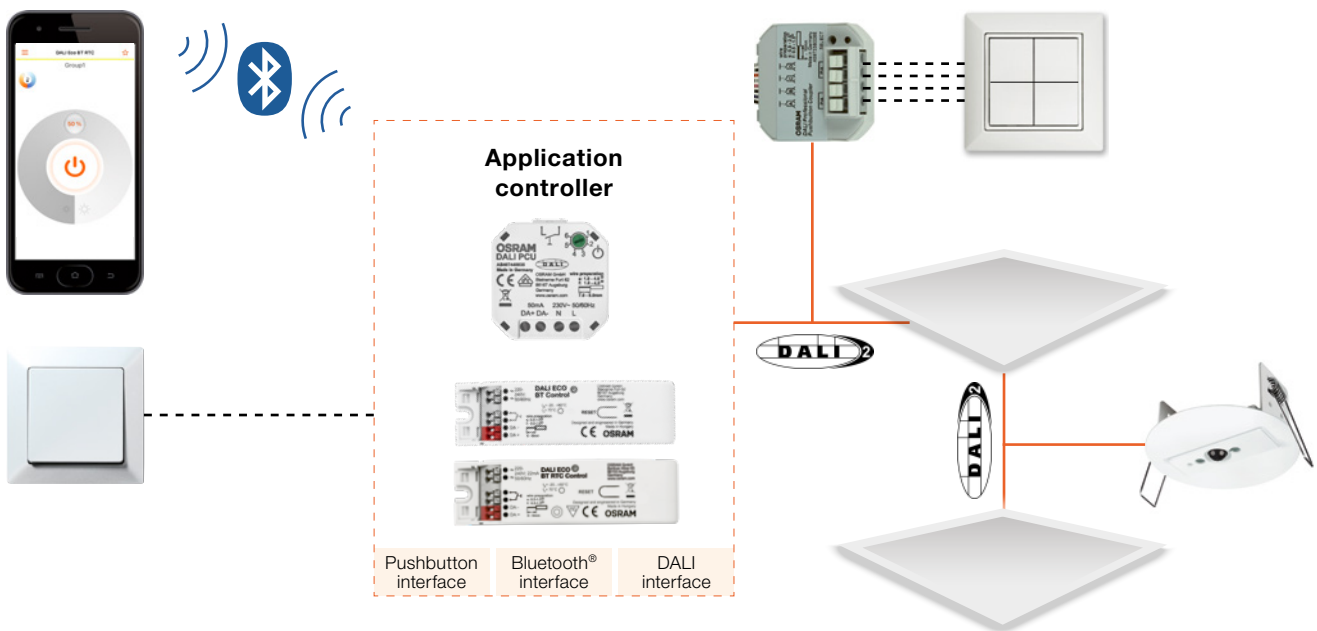

Certified DALI-2 interface

All BT Control devices are certified by the DiiA according to:

- IEC 62386-101: System components
- IEC 62386-103: Control devices

Certified product properties

- Application controller
- Provides bus power

Devices and functions supported by the DALI-2 interface

- Standard DALI LED drivers
- DALI-2 LED drivers
- LED drivers (part -207)
- Tunable White drivers (part -208)
- Feedback from drivers (incl. lamp failure)
- Addressing and grouping

Device interactions supported by DALI-2

- Event messages from input devices
- Pushbuttons (part -301)
- Occupancy sensors (part -303)
- Light sensors (part -304)

2.3.1 OSRAM DALI sensors and couplers G2 – DALI-2-certified

The following components can be combined with all three BT Control devices (all dimensions in m):

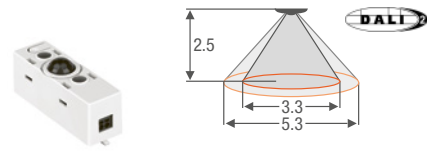

Mounting height	2	2.5	3	4	5
Presence	2.5	3.3	4	5	–
Motion	4.5	5.3	6	7	7

Name	EAN
DALI SENSOR LS/PD LI G2	4062172072069

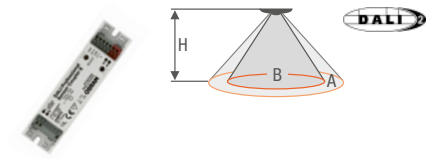

Range of third-party sensor					
-----------------------------	--	--	--	--	--

Name	EAN
DALI COUPLER E G2	4062172072212
ECO CI KIT (optional)	4008321392091

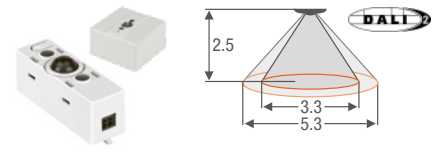

Mounting height	2	2.5	3	4	5
Presence	2.5	3.3	4	5	–
Motion	4.5	5.3	6	7	7

Name	EAN
DALI SENSOR LS/PD LI G2	4062172072069
LS/PD AP KIT	4052899173385

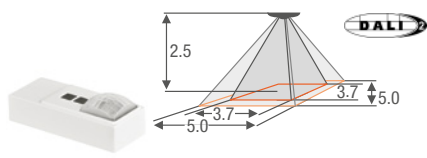

Mounting height	2	2.5	3	4
Presence	3	3.7	4.4	–
Motion	4	5	6	6.5

Name	EAN
DALI SENSOR LS/PD UF G2	4062172072045

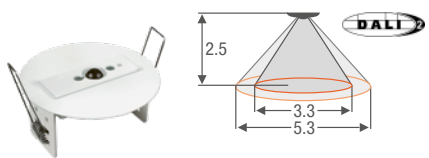

Mounting height	2	2.5	3	4	5
Presence	2.5	3.3	4	5	–
Motion	4.5	5.3	6	7	7

Name	EAN
DALI SENSOR LS/PD CI G2	4062172072083

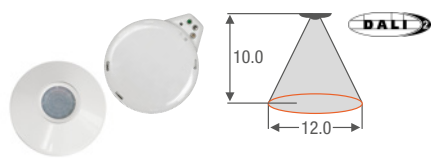

Mounting height	4	6	8	10	13
Presence	–	–	–	–	–
Motion	10	12	12	12	–
Vehicles	10	12	12	12	18

Name	EAN
DALI COUPLER LS HIGHBAY G2	4062172072137
HIGH BAY SENSOR	4008321410078

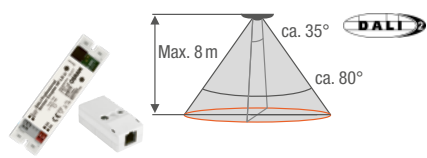

Mounting height	4	6	8	10
Presence	–	–	–	–
Motion	6.7	10	13.4	–
Vehicles	6.7	10	13.4	16

Name	EAN
DALI COUPLER HF G2	4062172072199
HF LS LI Sensor	4052899921481
ECO CI KIT (optional)	4008321392091

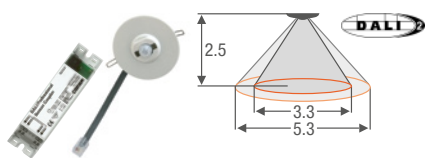

Mounting height	2	2.5	3	4	5
Presence	2.5	3.3	4	5	–
Motion	4.5	5.3	6	7	7

Name	EAN
DALI COUPLER MULTI 3 G2	4062172072113
LS/PD MULTI 3 CI	4008321916648
ECO CI KIT (optional)	4008321392091

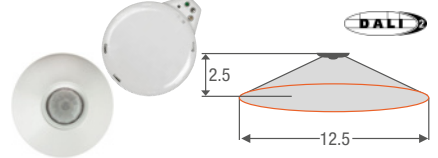

Mounting height	2	2.5	3	4	4.5
Presence	–	–	–	–	–
Motion	12.5	15.5	19	21	21

Name	EAN
DALI COUPLER LS HIGHBAY G2	4062172072137
VISION SENSOR	4008321957047



Name	EAN
DALI COUPLER PUSHB G2	4062172087575

2.3.2 OSRAM DALI pushbutton coupler G2 – function modes

The following pre-programmed function modes 1-6 can be activated while using OSRAM BT Control devices together with the DALI pushbutton coupler G2:

Name	Function of input A	Function of input B	Function of input C	Function of input D
1: 1-channel Tunable White (default)	SP [*] : Switch on/off LP ^{**} : Dim up/down Groups: All (1-4)	SP: Toggle scene LP: Change color temp. Groups: All (1-4)	SP: Recall scene 1 LP: --- Groups: All (1-4)	SP: Recall scene 2 LP: --- Groups: All (1-4)
2: 2-channel Tunable White	SP: Switch on/off LP: Dim up/down Group: 1	SP: Switch on/off LP: Dim up/down Group: 2	SP: --- LP: Change color temp. Group: 1	SP: --- LP: Change color temp. Group: 2
3: 2-channel dimming	SP: Switch on/off LP: Dim up/down Group: 1	SP: Switch on/off LP: Dim up/down Group: 2	SP: On LP: --- Groups: All (1-4)	SP: Off LP: --- Groups: All (1-4)
4: 4-channel dimming	SP: Switch on/off LP: Dim up/down Group: 1	SP: Switch on/off LP: Dim up/down Group: 2	SP: Switch on/off LP: Dim up/down Group: 3	SP: Switch on/off LP: Dim up/down Group: 4
5: Scene control	SP: Recall scene 1 LP: --- Groups: All (1-4)	SP: Recall scene 2 LP: --- Groups: All (1-4)	SP: Recall scene 3 LP: --- Groups: All (1-4)	SP: Recall scene 4 LP: --- Groups: All (1-4)
6: 1-group Tunable White and HCL¹⁾	SP: Switch on/off LP: Dim up/down Groups: All (1-4)	SP: --- LP: Change color temp. Groups: All (1-4)	SP: Recall scene 1 LP: --- Groups: All (1-4)	SP: HCL resume LP: --- Groups: All (1-4)

¹⁾ HCL only applicable with DALI ECO BT RTC Control device

^{*} SP = Short press

^{**} LP = Long press

2.3.3 Limitations on connectable devices

Relevant for all three OSRAM BT Control devices:

DALI ACU BT, DALI ECO BT and DALI ECO BT RTC (with integrated real-time clock)

Number of OSRAM DALI sensors	Number of OSRAM DALI PB couplers	Max. number of OSRAM DALI ECGs (at 25 °C ambient temperature)	Max. number of OSRAM DALI ECGs (at 60 °C ambient temperature)
1	0	32	32
	1	32	32
	2	32	32
	3	32	32
	4	32	32
2	0	32	32
	1	32	32
	2	32	32
	3	32	32
	4	32	32
3	0	32	32
	1	32	32
	2	32	32
	3	32	30
	4	28	26
4	0	32	30
	1	30	28
	2	28	26
	3	26	24
	4	24	22

2.4 General installation instructions

2.4.1 Safety instructions

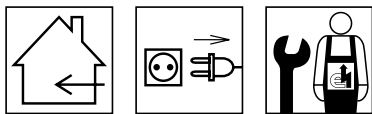

- Please read these operating instructions carefully before installing and using the OSRAM BT Control devices. This is the only way to ensure that you use the equipment safely and correctly. Keep these operating instructions in a safe place for future reference. You should make sure that everyone who uses OSRAM BT Control devices has read these operating instructions.
- Apart from the explicitly mentioned components, no further control units may be connected to the DALI lines.
- OSRAM BT Control devices may only be installed by qualified personnel who have been appropriately trained and who have the relevant authority. The installation personnel must be familiar with the operating instructions. Power must be switched off before any work is undertaken on the system.
- OSRAM BT Control devices units are especially designed for installation within luminaries (DALI ECO BT) or flush-mounted boxes (DALI ACU BT). An independent installation of DALI ECO BT is only allowed in combination with the mounting kit ECO CI Kit.
- The relevant safety and accident prevention regulations must be observed.
- If the control cables, sensor cables or the switch and/or the synchronization input is wired with external voltage, particularly with a mains voltage of 230 V, the unit may be destroyed.

2.4.2 Wiring instructions

DALI, sensor and pushbutton wires must never be connected or applied with mains voltage. Before connecting any new components, the mains supply of the control unit has to be switched off. After switching on the mains supply, the control unit automatically detects all connected components. The plug-and-play principle is valid, which means that there is no need to manually configure components to ensure a proper operation.

Interfaces (wired and wireless)	Maximum value
DALI control interface	Max. total wire length: 300 m
Pushbutton interface	Max. total wire length: 50 m (PB2 = 5 m for DALI ECO BT RTC only)
Wireless Bluetooth interface	Max. connectivity range: 15 m

Wiring of the DALI connection

The DALI standard requires basic insulation against mains. To fulfill the safety regulations, an additional insulation against mains is required. For DALI wiring, a cable suitable for line voltage is mandatory (even if in normal condition only 17 V_{DC} will be supplied). The terminals of the BT Control products are suitable for wire sections of 0.5 mm² to 2.5 mm². In order to not reduce the maximum cable length of a DALI installation (300 m), a wire section of at least 1.5 mm² is recommended.

DALI wires can be run with line voltage in the same cable. This means that, for example, an NYM-J 5 x 1.5 sheathed cable (where two wires are used for the DALI communication) is suitable. For DALI wiring, the usage of control and data cables such as LIYY or bell wire cables such as YR or comparable products are not allowed and a reliable operation may not be ensured.

Wiring of directly connected pushbuttons

For the wiring of directly connected pushbuttons, a cable suitable for line voltage has to be used. In principle, the pushbutton wires can be run in the same cable as the mains supply.

In case of longer cable lengths, or in case of incoupling disturbances that lead to a measurable AC disturbance voltage on the pushbutton wires, which may therefore lead to malfunctions, the usage of a DALI pushbutton coupler (or at least a separate pushbutton connection cable) is recommended.

The pushbutton wires have to be run locally separated from lamp or LED supply wires. Parallel-running lamp or LED supply wires may have a negative impact on the pushbutton function.

Wherever possible, crossing of pushbutton wires with lamp or LED supply wires should be at right angles to minimize capacitive coupling of disturbance signals.

Usage of small-signal or low-voltage pushbuttons is allowed as long as they provide a sufficient isolation (isolation voltage of at least 1500 V).

2.4.3 Radio optimization

The wireless Bluetooth Low Energy (BLE) interface is based on the Bluetooth 4.0 protocol.
Connectivity range: ≤ 15 m

DALI ECO BT, DALI ECO BT RTC

Mounting instructions

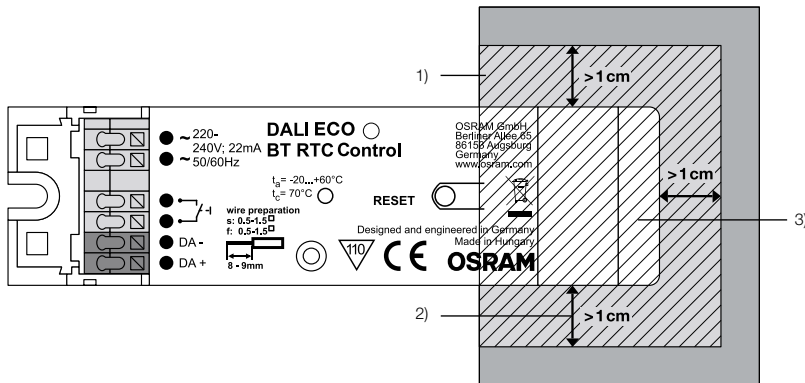

DALI ACU BT

Mounting instructions

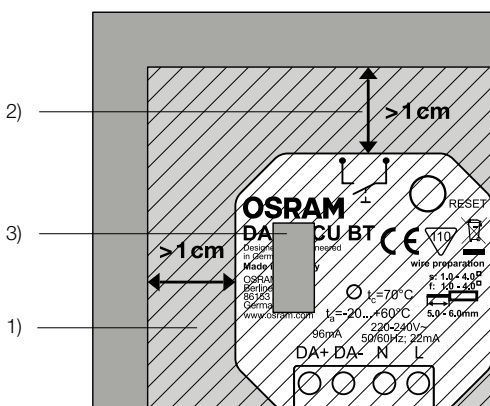

- 1) Do not place any mains voltage or LED supply wires within or close to this area
- 2) Recommended minimal distance to metal parts
- 3) Placement of integrated radio transmitter antenna

Guidelines for product placement to optimize the stability and effective range of the BT connection

1. Preferable installation on systems free from metal obstructions or material that heavily weakens the radio frequency signal (e.g. fiber-reinforced plastic).
2. Do not place inside metal boxes!
3. Keep a distance between the antenna area and the mounting surface (see best practice below).
4. Do not wire cables (mains voltage, LED supply wires) near the antenna area and, if possible, out of the device border.
5. Consider an installation height above the furniture and human obstacles (e.g. >1.6 m above the floor).

Best practice examples:

Floor-standing luminaire mounting

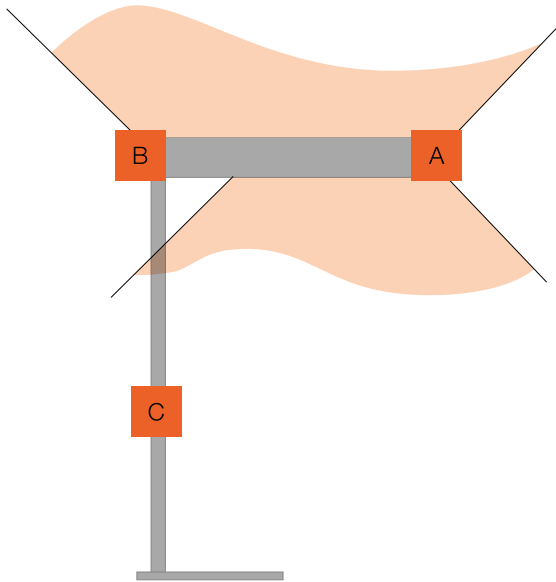

A: Luminaire head
 B: Transition area from pole to head
 C: Pole

General mounting rules:

- ✗ Metal surrounding the antenna
- ✗ Wires over antenna area
- ✗ No space for free BT transmission
- ✓ Non-metallic surrounding material
- ✓ > 1 cm of free space around antenna
- ✓ Space for free BT transmission

A Luminaire head:

On-top mounting

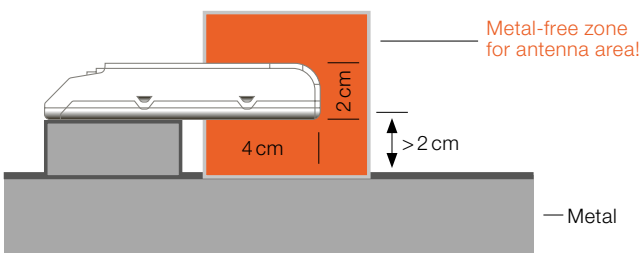

End mounting

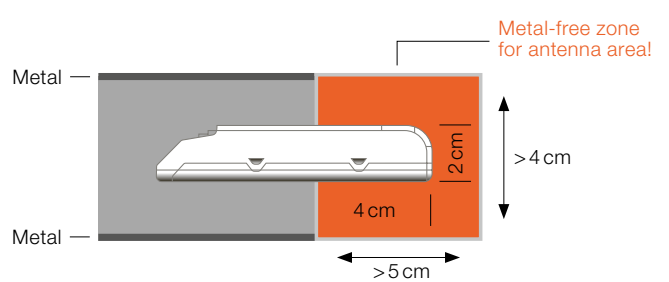

B Transition area:

Corner mounting

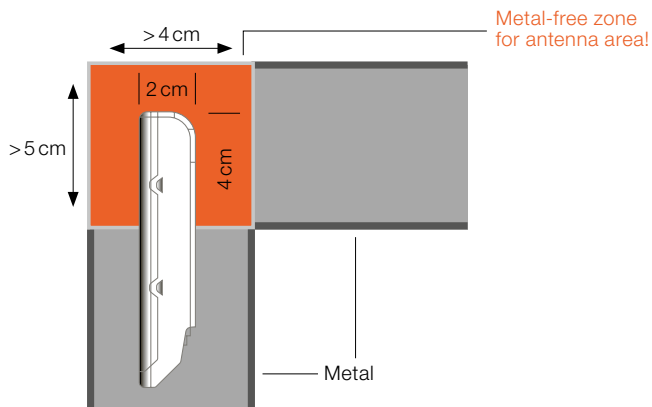

C Pole:

Pole integration

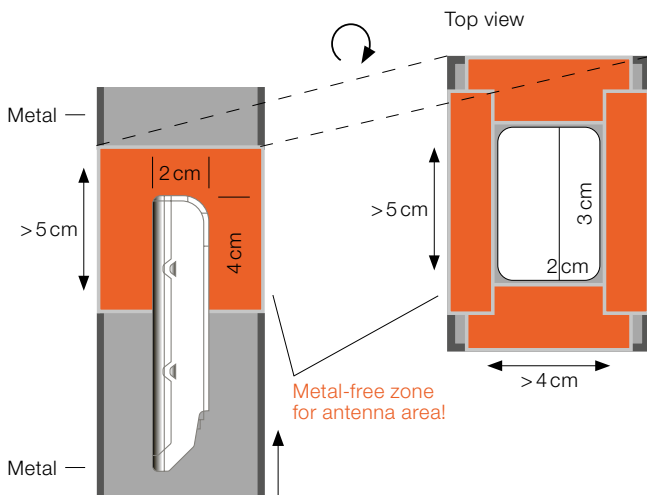

Function validation

To validate the assembly, the construction must be checked and the connection stability and connection distance tested. The check should be done using:

- The OSRAM BT app and a mobile device for testing the range of the mobile device to the BT antenna
- In case of Swarm function: A second BT Control device to test the point-to-point range between Swarm participants

Please note:

The result of the validation is not an index of replicability in all environments and application situations.

2.4.4 Light sensor placement and set point for light regulation

The light sensor measures the sum of daylight and artificial light reflected by a reference surface (e.g. tabletop or floor). For this purpose, the sensor must be directed as perpendicularly as possible to the reference surface. To achieve a proper function, the sensor must be placed so that the sensor receives the reflected light of luminaires connected to DALI channel 1.

Direct sunlight falling on the sensor has to be avoided, as well as unwanted measurement of the outside brightness through the sensor. Therefore, the sensor must not be mounted too close to the window. A sufficient change in the sensor reading through a change in the illumination is only guaranteed if the maximum mounting height is respected.

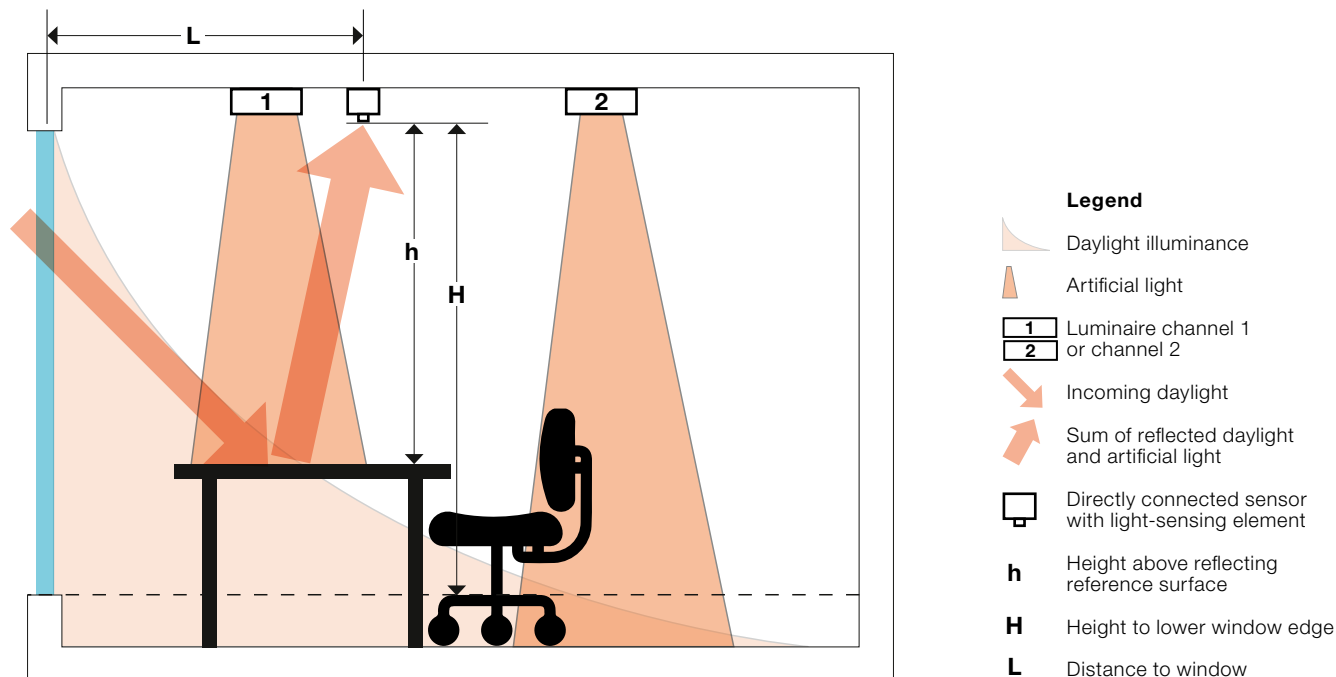

Min. and max. values that have to be observed

$$L > 0.5 \times H$$

Set point adjustment for daylight-dependent control

For the use of the daylight-dependent control function, a set point value must be defined. The set point adjustment must be performed with minimum daylight and additional light.

Automatic definition of the set point

Via an automatic setup process, the set point is set to 80 % of the maximum illuminance given by the artificial light. During the auto-setup process, the sensor LED flashes red and green alternatingly for about 3 minutes. For a meaningful measurement of the illuminance, it is important that there are no people or objects between the sensor and the reference surface until the auto-setup process is completed.

Manual adjustment of the set point

The set point for daylight control can be preset individually via the OSRAM BT Config App.

3 Control features

3.1 Standard features (available without app)

These are out-of-the-box functions that can be used right after connecting the devices and powering them up (no OSRAM BT Config App needed!).

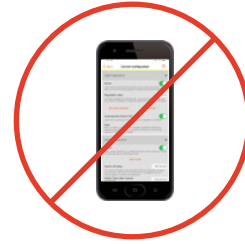

Basic system (controller + luminaire + pushbutton)

- Switch the light on and dim it via the directly connected pushbutton.
- Save the switch-on light level via double press on the pushbutton.
- Wireless light control with the User App (BT Control).
- OSRAM BT Config App access will be blocked after two hours to avoid hacking (the access will be enabled for two hours after each power cycle).

One or more OSRAM DALI sensor/s connected

- Presence detection enabled automatically (15-minute timer).
- Switch the light on and dim it via the connected pushbutton.
- Daylight harvesting enabled by double press on the connected pushbutton (DALI ECO BT RTC light regulation will be started automatically after clock synchronization via the app).

One or more OSRAM pushbutton coupler/s connected

- Automatically supported
 - PB 1: Switch and dim

3.2 Advanced features (available with app)

These are functions only configurable via the BT Config App.



Load/save a profile

- Main pre-programmed office application available
- Save all settings as a custom profile and apply it on multiple rooms

Light regulation/daylight harvesting (DLHV)

- Enable/disable
- Change setpoint
- Enable/disable switch-off when enough daylight is present

Motion detection

- Enable/disable
- Change delay time to choose between energy saving and user comfort
- Test mode to check the detection area
- Standby level to dim down before switching off

Additional settings

- State after power failure
- Min./max. DALI levels and color temperature
- Pushbutton interface configuration
- Adjustable PIR inhibit timer

3.2.1 Tunable White

The Tunable White function is enabled automatically if one (or more) DALI device type 8 Tunable White LED driver/s (DALI DT8 TW) is/are connected.

Out-of-the-box features

- OSRAM BT Control App will automatically display a color temperature control
- DALI PRO PB coupler supports color temperature control without using the app
 - Button 1: On/off/dim
 - Button 2: Change color temperature

Configurable with OSRAM BT Config App

- Store and recall scenes
- Change min. and max. color temperature limits
- Scene recall with the DALI pushbutton coupler

3.2.2 Group control

Group control can be configured via the OSRAM BT Config App and used via the OSRAM BT Control App.

Groupcast

- Individual control of up to four groups (dimming/changing color temperature)
- Flexible group assignment of every single luminaire

Extended light regulation functions

- Group 1 is the master for light regulation
- Groups 2, 3 and 4 can be enabled to follow group 1
- Individual offset can be set for group 2, 3 and 4 (typical requirement for classrooms)

Scene control

- Scenes can be stored with different light levels and color temperature for each group.

Pushbutton coupler support

- Scene recall
- Switching and dimming of up to four groups
- Switching/dimming and color temperature change of up to two groups

Sensor support

- Enable/disable a single sensor (light or motion), which affects all groups

3.2.3 Swarm feature

The Swarm feature enables a wireless communication between BT Control devices to share presence information. Only available in **“Expert User”** mode (see 4.5):

Use case 1: Multiple luminaire groups switch on together based on a wireless BT connection (without wired DALI connection!).

Use case 2: Basic brightness level in an open-plan office due to wireless standby activation.

3.3 Special features of DALI ECO BT RTC

Additional out-of-the-box features compared to the non-RTC BT Control devices

- Switch/dim/change color temperature via connected pushbuttons
- Starts HCL curve after connecting with an app (OSRAM BT Control App is sufficient)

The real-time clock (RTC) with an energy buffer of 72 hours (needs 24 hours mains connection to be fully loaded) enables daytime-related functions such as:

- Human Centric Lighting (HCL)
- Timer (automatic, weekday and daytime-related start and stop of the light system)

3.3.1 Human Centric Lighting (HCL)

The HCL function includes:

- Automatic change of color temperature and brightness during daytime
- Preset HCL curve
- Easily adaptable HCL curve

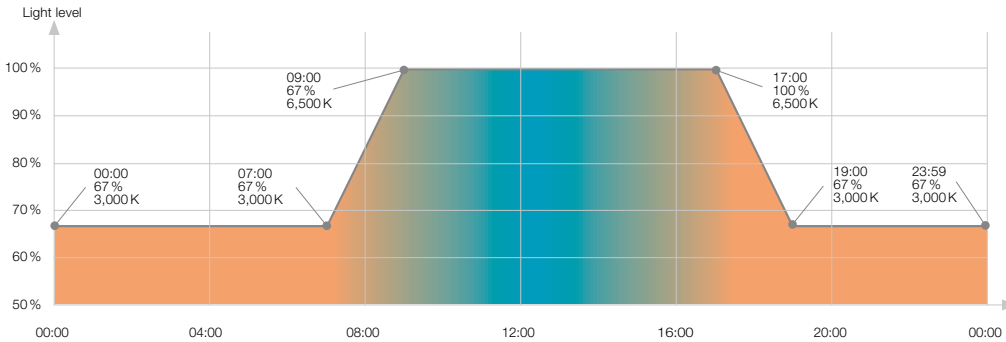

HCL will start automatically with default settings after synchronizing the real-time clock. Automatic sync done by connecting with the OSRAM BT Control or Config App.

- The HCL curve can be easily adapted via the OSRAM BT Config App.
- Up to 24 points can be added or modified in the HCL curve.
- Each point consists of:
 - Daytime
 - Light level
 - Color temperature
- The fast-play button shows the HCL curve in a time lapse reducing the 24 hours to 72 seconds.
- Daylight harvesting with dynamic setpoint possible. Light regulation setpoint according to the HCL brightness curve.

3.3.2 Timer

The timer function includes up to four different timers.

Example with HCL function activated:

Timer 1: Days = Mon./Tue./Wed./Thu.; Time = 08:00–18:00

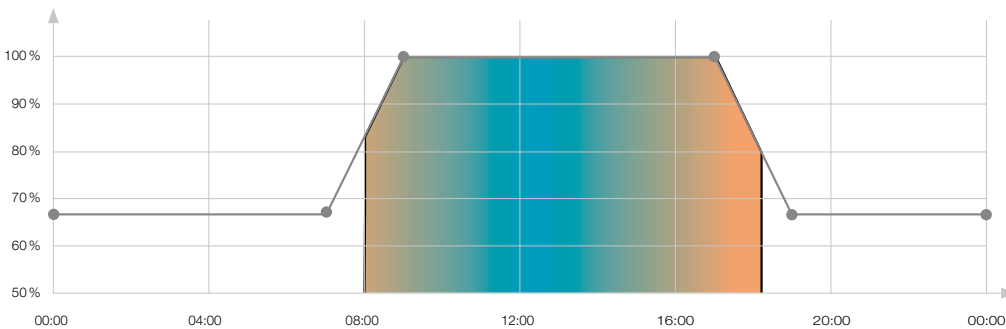

Timer 2: Days = Fri.; Time = 08:00–12:00

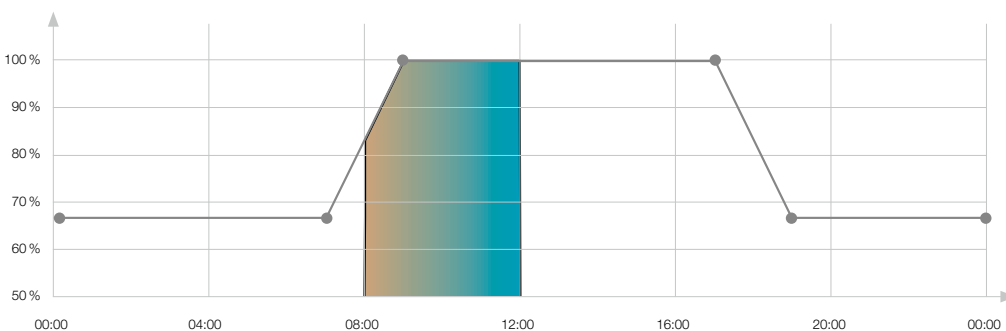

Up to four different timers can be activated to configure the devices to start and stop automatically.

- Each timer features:
 - Start time
 - Stop time
 - Weekdays (one or more weekdays can be chosen per timer)

3.4 Demo mode

Both Apps – OSRAM BT Config App and BT Control App – provide a demo mode to simulate a connected device.

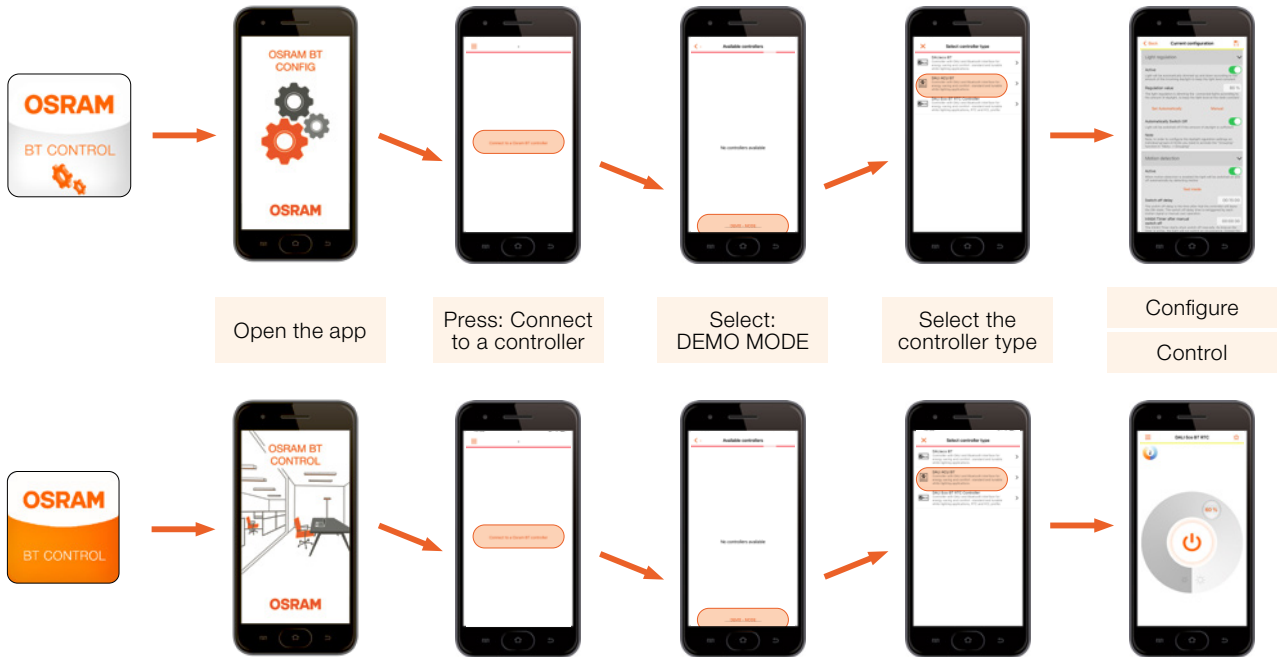

4 Configuration of multiple devices

New feature
available in the
BT Config App

4.1 Overview

Benefits

- Allows serial updating of up to 10 BT Control products (DALI ECO BT, DALI ECO BT RTC and DALI ACU BT are supported)
- Group addresses of drivers can be pre-programmed via T4T ¹⁾

Main user advantage

- In order to shorten luminaire production time, BT Control products can be pre-commissioned before assembling the luminaire.

Configurable features

- Firmware update
- Reset to factory new
- Synchronize RTC (DALI ECO BT RTC only)
- Set admin password
- Set user password
- Upload profile with custom settings

Please note:

This feature is only visible in Expert mode. For details, please see chapter 4.2.2.

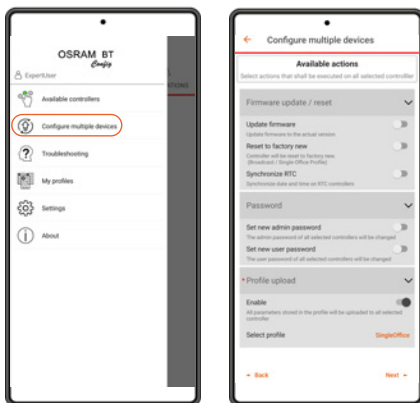

1) If the DALI driver with assigned group addresses is connected to the BT Control products, and the grouping function is already enabled, the lowest group address between 1-4 will be used (all other group addresses will be deleted).

4.2 Three steps for luminaire production with BT Control products



1 Configure the reference luminaire and save the profile.

2 Upload the profile to multiple BT Control devices.

3 Assemble the luminaires and perform all necessary function tests without the need of an app.

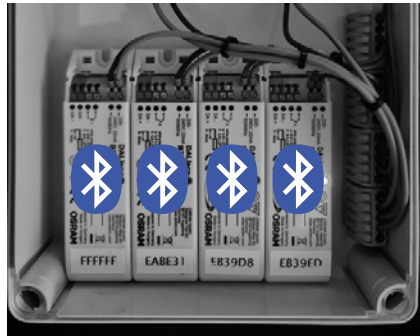

4.2.1 Step 1: Commissioning of a reference luminaire



The reference luminaire must be equipped with an OSRAM BT Control product and the OSRAM BT Config App.

- 1** Connect the reference luminaire to the controller via Bluetooth.
- 2** Adapt the settings of the controller (actual configuration).
- 3** Adapt the pushbutton profiles.
- 4** Enable grouping (if needed).
- 5** Adapt the individual settings for each group (light regulation on/off, offset, switch-on level, scenes etc.).
- 6** Adapt the input device profiles.
- 7** Perform a light regulation calibration if light regulation is enabled.
- 8** Save all settings as a new profile.

4.2.2 Step 2: Upload the configuration to multiple BT Control products

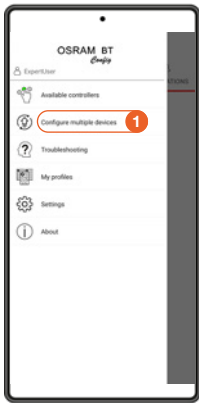

1 Open the app and select “Configure multiple devices” in the menu.

Please note:

- This feature is only visible in the Expert mode
- To enable the Expert mode, open “Settings” and “Profile”.

Please enter the following:
Name: **ExpertUser**
Company: **OSRAM**

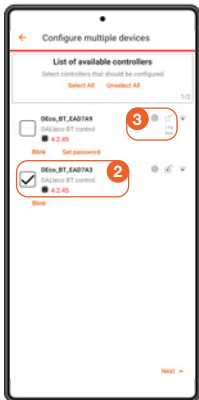

2 Select available devices that shall be configured.

Please note:

- The app will be scanning for BT Control products via Bluetooth interface and will enable a one-to-one Bluetooth connection to download the information from each device.
- A device can be selected if the app has access to the controller.
- Factory-new devices have a 120-minute timer after power-up, before the access is blocked, as long as no password is set. **The remaining time is displayed next to the device (3).**
- If a device is password-protected and the password is stored in the app, it can be selected.
- If a device is locked via password (with another smart device), it must be unlocked by entering the password before it can be configured.

Important note:

After powering up the controller, it can be configured with the BT Config App **for two hours only (as long as no admin password is stored)**. After the two-hour delay time has expired, connecting to the controller with the BT Config App is blocked. The timer can be reset by power-cycling the controller. When an admin password is set, the access to the controller will no longer expire.

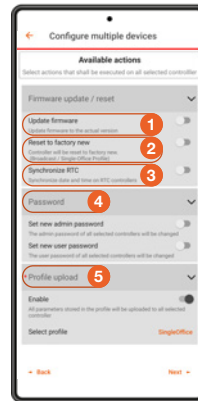

Enable the actions that shall be performed

1 Update firmware:

- Always enable this feature to ensure that the latest firmware is uploaded to the device.

2 Reset to factory new:

- Only enable if you want to reset the configuration to “factory new”.

3 Synchronize RTC:

- Only valid for the DALI ECO BT RTC. If enabled, the date and time will be synchronized with the controller.
- If Human Centric Lighting (HCL) is enabled in the profile (default), the controller will use the brightness level and color temperature of the HCL profile when switched on.

4 Password:

- An admin and a user password can be set to limit the access to the controller via OSRAM BT Config App or OSRAM BT Control App.
- When an admin password is set, the 120-minute timer for access to the controller via OSRAM BT Config App is disabled.

5 Profile upload

- Any profile stored in the app can be uploaded to the device.
- The profile includes:**
- All settings included in the current configuration menu
 - Active profile of the integrated pushbutton
 - Setpoint for light regulation (if active and stored when the profile was saved)

Please note: The controller will perform a calibration of the first setpoint for light regulation if active and stored.

Not stored in the profile:

Information of connected input devices (sensors, pushbutton couplers)

Important notes:

- Up to 10 BT Control devices can be configured in series.
- The devices can be powered via mains or alternatively via DALI.
- The progress of the configuration upload will be logged in the app.

Configuration status indicated via LED:

- Blue LED **on**: Smart device connected to the device (uploading)
- Blue LED **flashing slowly** (1 Hz): Upload successful
- Blue LED **flashing quickly** (2 Hz): Upload failed



Option A: Devices powered via mains (~230 V)

- Each device consumes 22 mA
- Protection against mains during commissioning needed

Mains power supply ~230 V

Option B: Devices powered via DALI (16 V_{DC})

- Each device needs at least 150 mA DALI power for safe communication
- Each device needs a separate DALI power supply
- Controllers shall not communicate with each other

DALI power supply 150 mA per device

4.2.3 Step 3: Assembly of the luminaire in production

Just like other luminaire components, the pre-configured controller can be assembled without the need of a smart device for configuration during production.

Benefits for luminaires with integrated BT Control device

- After assembling the luminaire, all functional and safety tests can be performed without the need of a smart device.
- No additional configuration step needed. **This saves a lot of time and effort.**

Benefits for luminaires with two groups (direct/indirect light): DALI ECO BT RTC

- Group addresses of DALI LED drivers can be pre-programmed, e.g. OSRAM DALI drivers can be programmed via Tuner4TRONIC (T4T) software.
- Internal pushbutton configuration already uploaded during step 2.
- After assembling the luminaire, all functional and safety tests can be performed without the need of a smart device (separate switching of direct/indirect light).
- The luminaire can be packed directly into the shipping box. **This saves a lot of time and effort.**

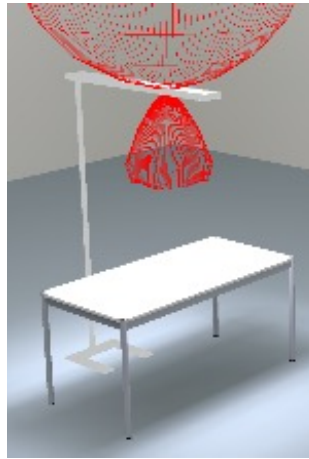

5 Applications and settings

Different applications have different functional demands and need different system settings. Here are some application use cases with the respective functional settings:

5.1 Stand-alone luminaire/s with integrated BT Control

Pendant, mounted or floor-standing luminaires with one (direct) or two (direct/indirect) light outputs

5.1.1 Floor-standing luminaire with 1 x DALI LED driver (with out-of-the-box light functions)

5.1.1.1 Requirements

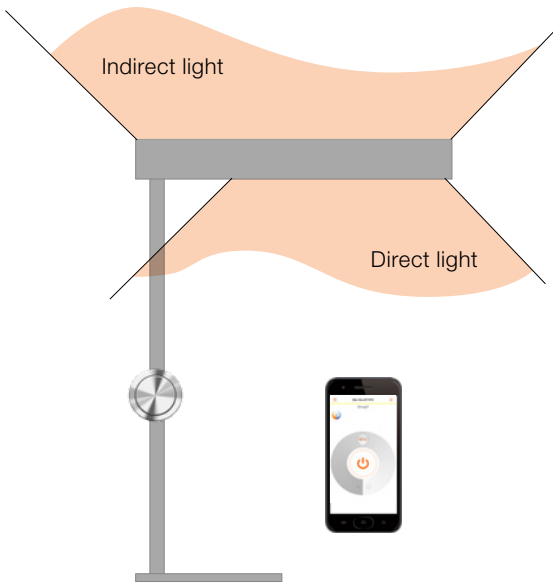

The floor-standing luminaire can be switched and dimmed with one pushbutton.

The integrated presence sensor automatically detects presence and turns the light on (and off again after a 15-minute delay time).

To keep the level at the sensor constant, the integrated light sensor dims the light up and down according to the amount of daylight.

The light can be switched on and off and dimmed via a smart device.

5.1.1.2 Product setup and wiring diagram

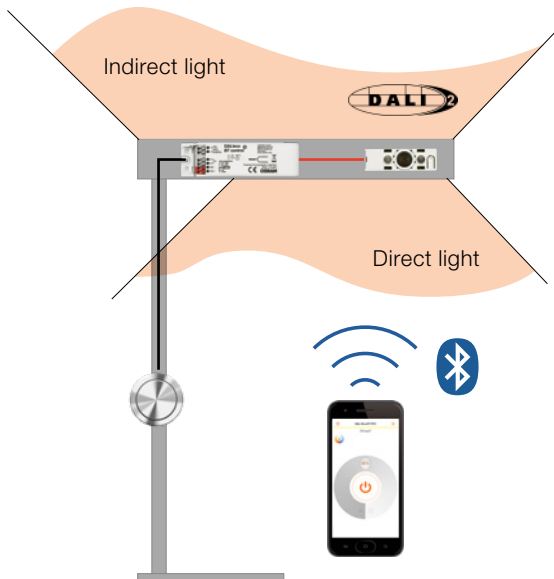

Solution with DALI ECO BT

1 x DALI ECO BT
Application controller



1 x DALI sensor LS/PD LI G2
Light and presence sensor



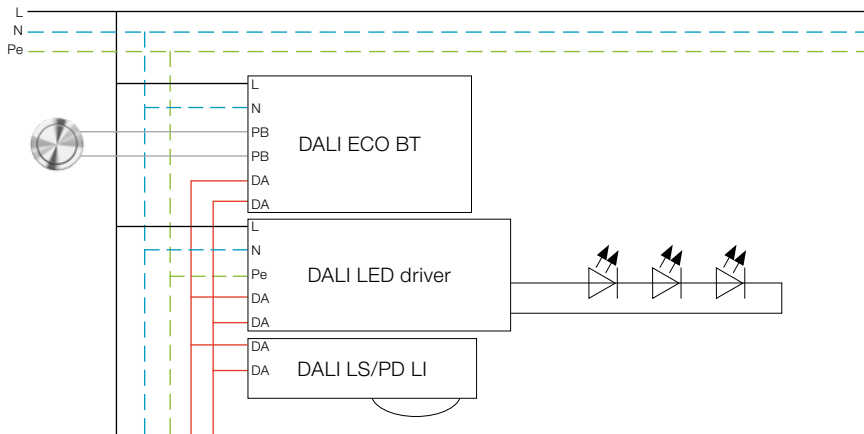

5.1.1.3 Out-of-the-box features (no app for configuration needed!)

Manual control via the connected pushbutton

- Short press: On/off
- Long press: Dim up/down
- Double press: Storing the actual light level as setpoint for DLHV (daylight harvesting)



Control via smartphone with the OSRAM BT Control App

- User can switch the light on/off and dim it via smartphone
- User can set a password to limit access



5.1.1.4 Additional configuration options via the OSRAM BT Config App

The controller can be configured via smartphone with the OSRAM BT Config App.



The BT Config App configuration is not mandatory, but enables more flexibility to adapt the behavior to the customer requirements.

Important note:

After powering up the controller, it can be configured with the BT Config App **for two hours only (as long as no admin password is stored)**. After the two-hour delay time has expired, connecting to the controller with the BT Config App is blocked. The timer can be reset by power-cycling the controller. When an admin password is set, the access to the controller will no longer expire.

Important note:

Save all settings as a profile and use the “Configure multiple devices” feature (see chapter 4) to upload the same settings on multiple BT Control products. This saves time during luminaire production.

The following features are a selection of the most popular project-specific adaptations. There are also many additional settings which can be looked up in the app.

5.1.1.5 Password protection

When connecting to the OSRAM BT Config App for the first time, a window pops up where an admin password and the user password can be set.

If you want to add or change the password, follow steps below:

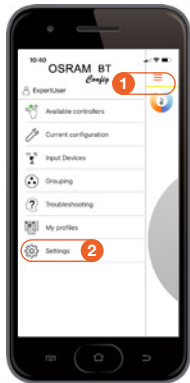

Set the admin/user password

- 1 Open the main menu.
- 2 Open “Settings”.
- 3 Open “Password”.
- 4 Enter an admin password to restrict the connection with the OSRAM BT Config App.

Please note: When the admin password is empty, you can only connect to the controller within two hours after connecting to mains. To reconnect after this time, you need to power-cycle the controller.

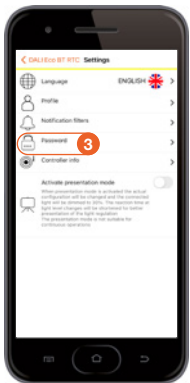

- 5 Enter a user password to restrict the connection with the OSRAM BT Control App.

- 6 Enable “Lock user password” to restrict the change of the user password via the OSRAM BT Control App.

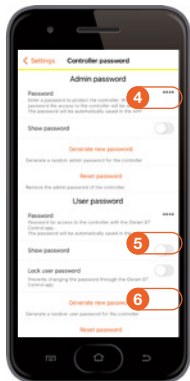

5.1.1.6 Switch-off delay time

The switch-off delay is the time after which the controller will leave the “on-state”. The switch-off delay timer is retriggered by each motion signal or manual user operation. The light will go **off** when no standby level is activated.

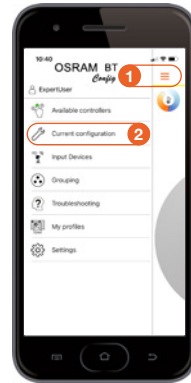

Change the switch-off delay time

- 1 Open the main menu.
 - 2 Open “Current configuration”.
 - 3 Open “Motion detection” and go to “Switch off delay”.
- Change the switch-off delay time according to your preferences.

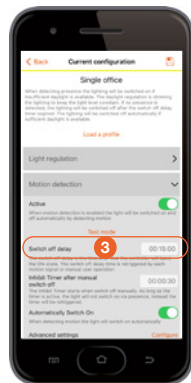

5.1.1.7 Standby level and time

When activated, the light will go to the standby level after the switch-off delay time has expired. The light will switch **off** after the standby time has expired.

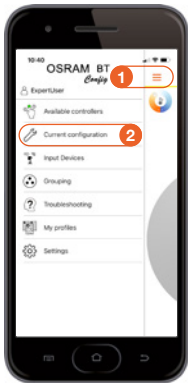

Activate the standby level and time

- 1 Open the main menu.
- 2 Open "Current configuration".
- 3 Open "Advanced settings".

Activate **standby level** and define the **standby level** and **standby time** according to your needs.

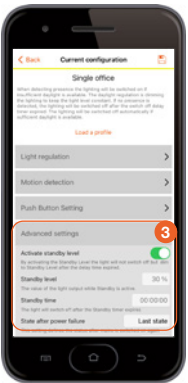

5.1.1.9 State after power failure

"State after power failure" defines the behavior of the connected DALI LED drivers after a power failure.

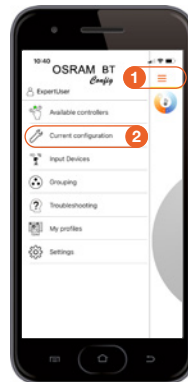

Change the state after power failure

- 1 Open the main menu.
- 2 Open "Current configuration".
- 3 Open "Advanced settings" and go to "State after power failure".

Change the **state after power failure** between **on/off/last state/standby** according to your needs.

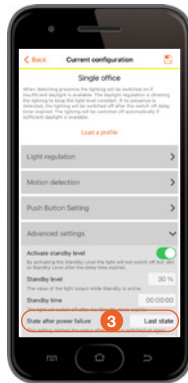

5.1.1.8 PIR inhibit timer after manual switch-off



Activate the standby level and time

- 1 Open the main menu.
- 2 Open "Current configuration".
- 3 Open "Motion detection".

Change the **inhibit timer after manual switch-off**.

The timer starts when manually switched off via pushbutton or app. As long as the timer is active, the presence sensor will not switch on the light. Instead, it will retrigger the timer.

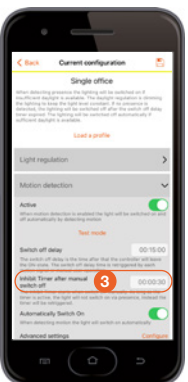

- Change the setting to 01:00:00 to be sure that the light will not switch on automatically when you come back from a lunch break.
- Leave it at 00:00:30 sec if you want the automatic switch-on to be active again after you have left the room.

5.1.2 Floor-standing luminaire with 2 x DALI drivers separating the direct and indirect light

5.1.2.1 Requirements

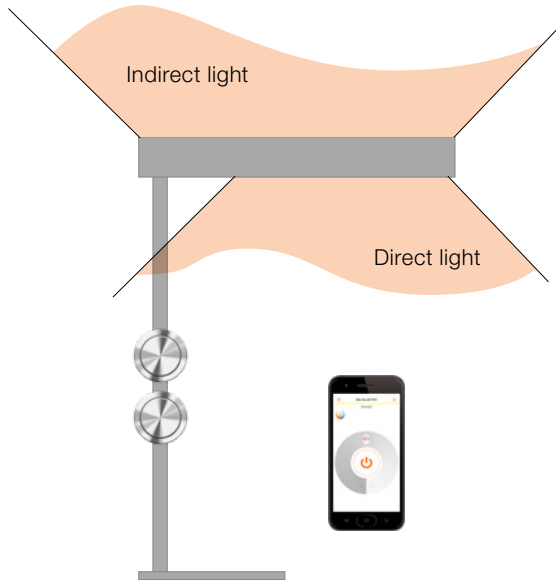

The floor-standing luminaire can be switched and dimmed with two pushbuttons.

The integrated presence sensor automatically detects presence and turns the light on (and off again after a 15-minute delay time).

Daylight harvesting should be active for the direct light and a constant light level should be active for the indirect light. To keep the level at the sensor constant, the integrated light sensor dims the light up and down according to the amount of daylight for the direct light output only.

The two light outputs can be switched and dimmed separately via a smart device.

5.1.2.2 Product setup and wiring diagram

DALI ECO BT RTC with resistor

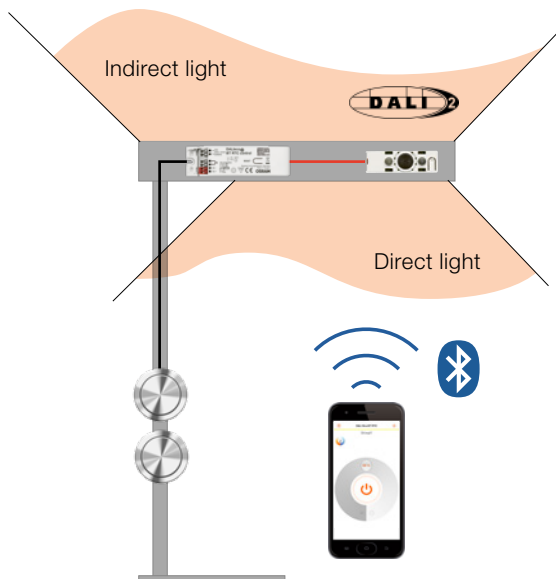

Solution with DALI ECO BT RTC

1 x DALI ECO BT RTC
Application controller



1 x DALI sensor LS/PD LI G2
Light and presence sensor



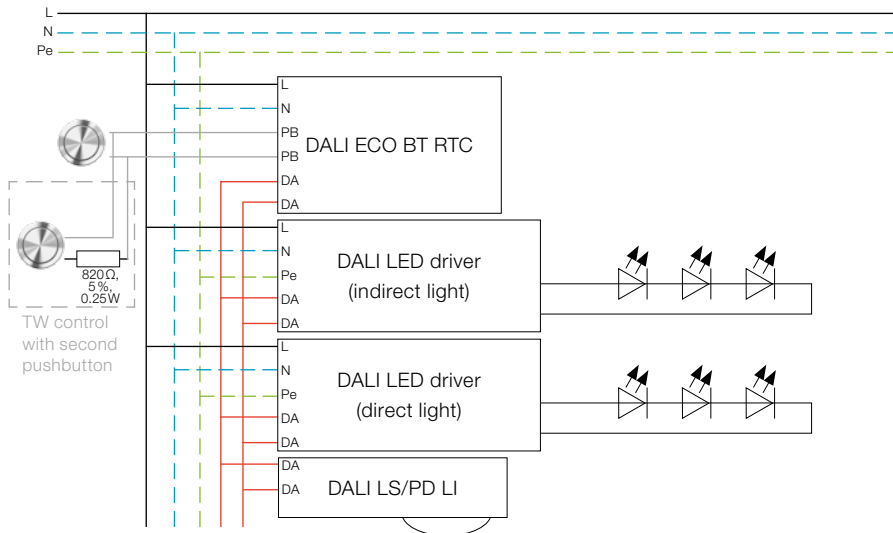

5.1.2.3 Out-of-the-box features (no app for configuration needed!)

Attention: For this application, the out-of-the-box features are **not** sufficient.

Additional configuration via the **OSRAM BT Config App** is required (see chapter 5.1.2.3 ff.)!

5.1.2.4 Configuration via the OSRAM BT Config App

The controller can be configured via smartphone with the OSRAM BT Config App.

The BT Config App configuration is **mandatory** for this application!

The grouping feature needs to be activated, the HCL function needs to be deactivated and the two pushbuttons need to be configured as well.

Important note:

After powering up the controller, it can be configured with the BT Config App **for two hours only (as long as no admin password is stored)**. After the two-hour delay time has expired, connecting to the controller with the BT Config App is blocked. The timer can be reset by power-cycling the controller. When an admin password is set, the access to the controller will no longer expire.

The following features are a selection of the most popular project-specific adaptations. There are also many additional settings which can be looked up in the app.

5.1.2.5 Password protection

Please see 4.1.1.5: Password protection

5.1.2.6 Grouping

Grouping is necessary as a differentiation between the direct and indirect light output is wanted. After the grouping process is finished, the light/s assigned to one group can be controlled separately from the other group/s.

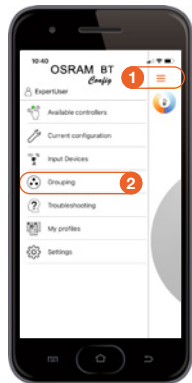

Group the luminaires

- 1 Open the **main menu**.
- 2 Open **“Grouping”** in the main menu.
- 3 Start the addressing procedure by selecting **“Activate Grouping”**.
- 4 All found **LED drivers** will be listed and **automatically** assigned to **Group 1**.

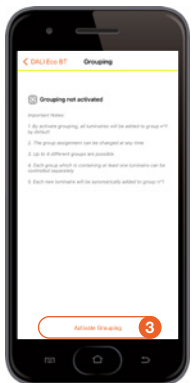

After **selecting one device**, the connected luminaire starts flashing.

- 5 After **selecting the group number**, the number changes 1-2-3-4-1 ..., as up to four groups can be configured.

Group 1 = Direct light
Group 2 = Indirect light

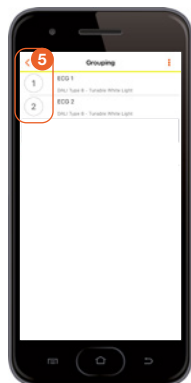
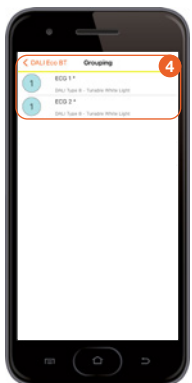

5.1.2.7 Daylight harvesting (DLHV)

The daylight harvesting function is automatically activated when a corresponding daylight sensor is connected. As only the direct light (Group 1) will use this light regulation, the indirect light (Group 2) needs to be disabled:

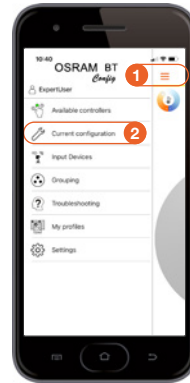

Activate the light regulation

- 1 Go back to the **main menu**.
- 2 Open **“Current configuration”**.
- 3 Open **“Light regulation”**.

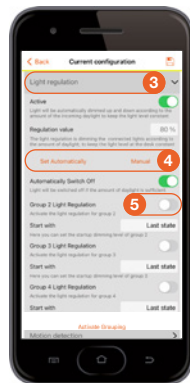

- 4 Define the required **light level** by choosing **“Set Automatically”** or **“Manual”**.

- 5 Disable **“Group 2 Light Regulation”** as Group 2 (indirect light) should always stay at the same light level.

5.1.2.8 Pushbutton configuration

The out-of-the-box (default) behavior of the pushbutton is controlling all light groups at the same time. An independent control of different groups has to be adapted accordingly:

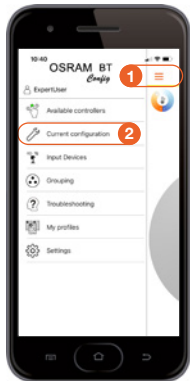

Set the pushbutton configuration

- 1 Open the main menu.
- 2 Open “Current configuration”.
- 3 Open “Push Button Setting”.
- 4 Click on “Configure” for the “Push button behavior”.
- 5 Open the “Integrated Push Button”.
- 6 Click on “Profile” and choose the respective profile for
Group 1: On/off/dim
Group 2: On/off/dim

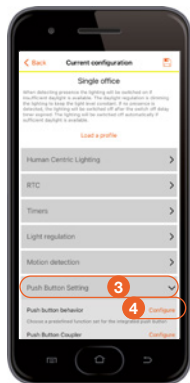

5.1.2.9 HCL deactivation

The out-of-the-box function package of the DALI ECO BT RTC includes an automatic activation of the Human Centric Lighting (HCL) function as soon as the OSRAM BT Control App is connected. The automatic HCL function will override the DLHV function. In order to use daylight harvesting as intended in this application example for direct light (group 1), it is therefore necessary to deactivate the HCL beforehand.

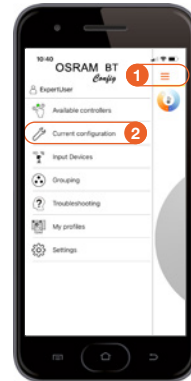

Deactivate the HCL function

1. Open the main menu.
2. Open “Current configuration” in the main menu.
3. Open “Human Centric Lighting”.
4. “Disable HCL” in the Status menu.

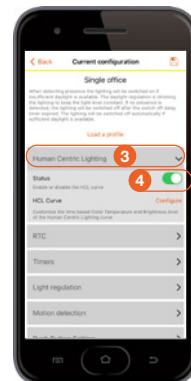

Important note:

Save all settings as a profile and use the “Configure multiple devices” feature (see chapter 4) to upload the same settings on multiple BT Control products. This saves time during luminaire production.

- Internal pushbutton settings will be stored in the profile.
- Group addresses of LED drivers can be pre-programmed to save time during luminaire production.

5.1.3 Floor-standing luminaire with 1 x DALI LED driver and active HCL function

5.1.3.1 Requirements

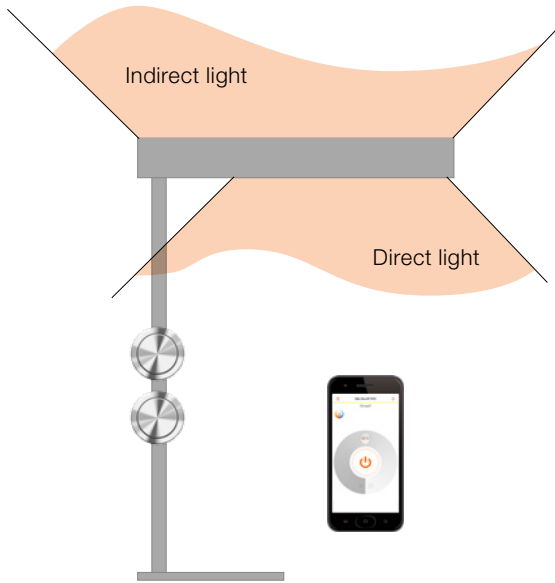

The floor-standing luminaire can be switched, dimmed and tuned (Tunable White) with two pushbuttons.

The integrated presence sensor automatically detects presence and turns the light on (and off again after a 15-minute delay time).

HCL (Human Centric Light) should be active based on a pre-defined daylight curve for artificial daylight simulation running during business hours while presence is detected.

5.1.3.2 Product setup and wiring diagram

DALI ECO BT RTC with resistor

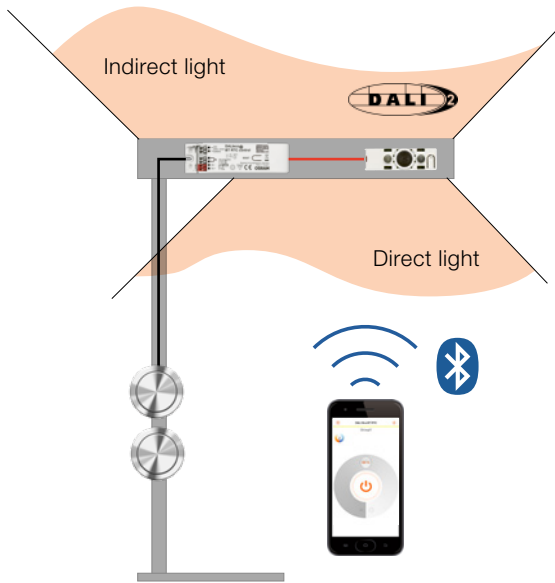

Solution with DALI ECO BT RTC

1 x DALI ECO BT RTC
Application controller



1 x DALI sensor LS/PD LI G2
Light and presence sensor

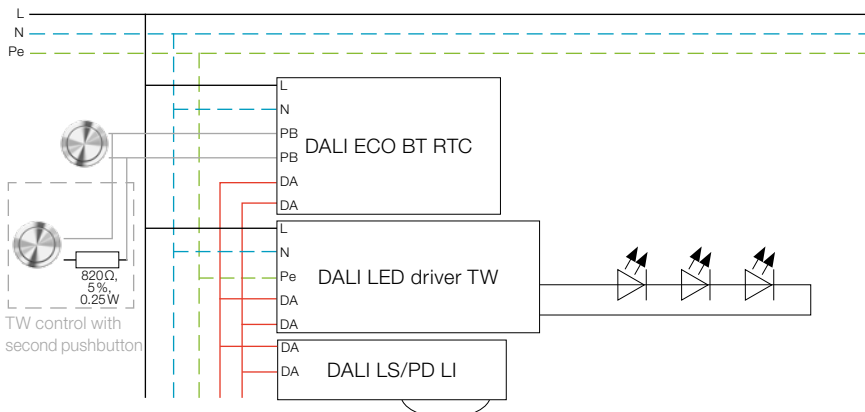

5.1.3.3 Out-of-the-box features (no app for configuration needed!)

Manual control via two directly connected pushbuttons

Button 1:

- Short press: On/off
- Long press: Dim up/down



Button 2 (with resistor):

- Short press: Scene toggle
- Long press: Tune cold/warm (Tunable White)



Control via smartphone with the OSRAM BT Control App

- By connecting the Control App and synchronizing the RTC (real-time clock) in the DALI ECO BT RTC, the user **automatically starts the HCL function**, which is based on a pre-defined light curve.
- The user can switch and dim the light via smartphone.
- The user can tune the light via smartphone (Tunable White).
- The user can set a password to limit access.



5.1.3.4 Additional configuration options via the OSRAM BT Config App

The controller can be configured via smartphone with the OSRAM BT Config App.

For using the HCL function, the BT Config App configuration is not mandatory, but enables more flexibility to adapt the behavior to the requirements of the customer.



Important note:

After powering up the controller, it can be configured with the BT Config App **for two hours only (as long as no admin password is stored)**. After the two-hour delay time has expired, connecting to the controller with the BT Config App is blocked. The timer can be reset by power-cycling the controller. When an admin password is set, the access to the controller will no longer expire.

The following features are a selection of the most popular project-specific adaptations. There are also many additional settings which can be looked up in the app.

5.1.3.5 Password protection

Please see 5.1.1.5: Password protection

5.1.3.6 HCL activation and adaptation

The firmware of the DALI ECO BT RTC Control device consists of a pre-defined HCL curve, which can be automatically started by connecting the OSRAM BT Control App, including automatic synchronization of the real-time clock. If the pre-defined light curve does not fit to the customer requirements, the curve can be easily adapted and stored as a new HCL curve.

Important note:

After activation of the **HCL function, the light curve brightness points are active!** This means that if the DLHV (daylight harvesting) function is active at the same time, the HCL curve is in the lead and **HCL will override DLHV** (see chapter 4.1.2.7).

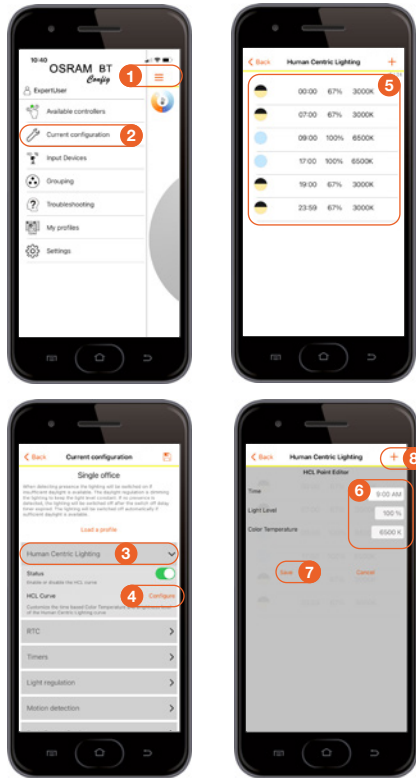

Activate the HCL function

1. Open the main menu.
2. Open “Current configuration” in the main menu.
3. Open “Human Centric Lighting” and “Enable HCL”, which starts a pre-programmed HCL curve.
4. If needed, “configure” the HCL curve according to the application needs.
5. Click on any of the available light curve points for modification.
6. “Time”, “Light Level” and “Color Temperature” can be configured.
7. If changes have been made, please click on “Save”.
8. To insert additional light curve points, please click on the “+”.

This diagram shows the pre-programmed HCL light curve:

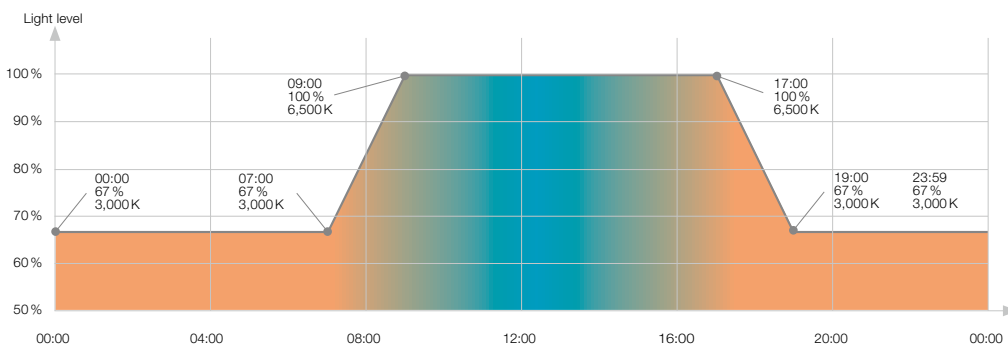

Important note:

Save all settings as a profile and use the “Configure multiple devices” feature (see chapter 4) to upload the same settings on multiple BT Control products. This saves time during luminaire production.

5.2 Single-room applications with integrated BT Control

Single office, open-plan office, corridor or classroom applications with automatic sensor control and/or manual pushbutton control for pendant, mounted or floor-standing luminaires with one (direct) or two (direct/indirect) light outputs.

5.2.1 Single office (with out-of-the-box light functions)

5.2.1.1 Requirements

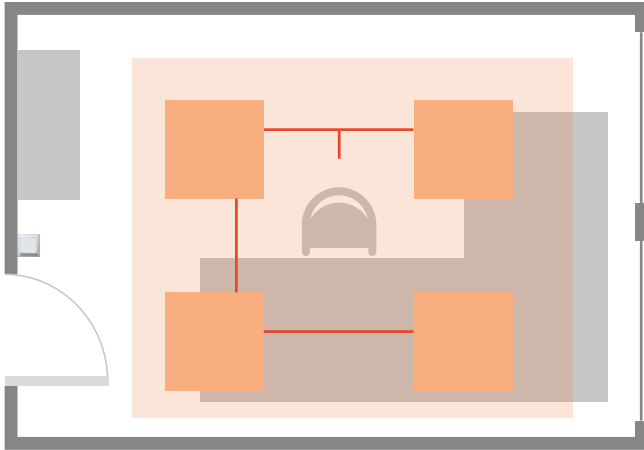

The office luminaires can be switched and dimmed with one pushbutton.

The integrated presence sensor automatically detects presence and turns the light on (and off again after a 15-minute delay time).

During presence, the daylight harvesting function will dim the artificial light up and down according to the amount of daylight available.

5.2.1.2 Application setup and wiring diagram

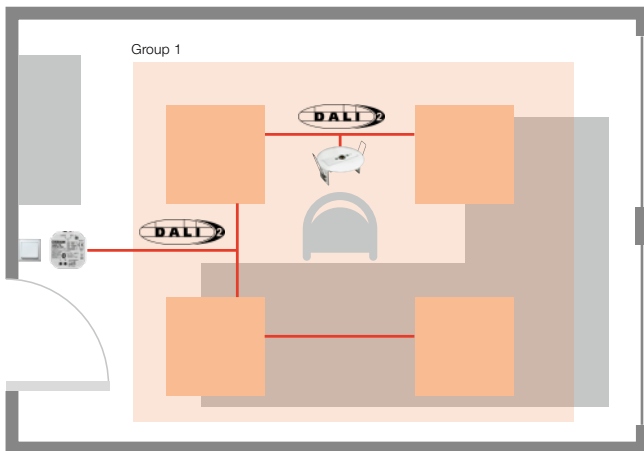

Solution with DALI ACU BT

4 x standard DALI-2 luminaire

1 x DALI sensor LS/PD CI G2

Light and presence detector for ceiling integration

1 x DALI ACU BT

DALI-2 controller (in flush-mounted box)

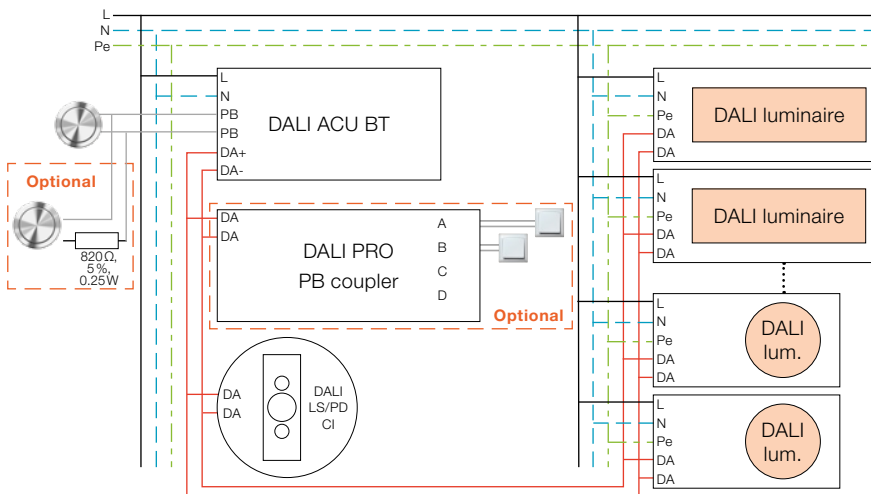

5.2.1.3 Out-of-the-box features (no app for configuration needed!)

Manual control via the connected pushbutton:

- Short press: On/off
- Long press: Dim up/down
- Double press: Storing the actual light level as set point for DLHV (daylight harvesting)



Optional: Second pushbutton (with resistor):

- Short press: Scene toggle
- Long press: Tune cold/warm (Tunable White)



Optional: Pushbutton coupler:



Name	Function of input A	Function of input B	Function of input C	Function of input D
1: 1-channel Tunable White (default)	SP*: Switch on/off LP**: Dim up/down Groups: All (1-4)	SP: Toggle scene LP: Change color temp. Groups: All (1-4)	SP: Recall scene 1 LP: --- Groups: All (1-4)	SP: Recall scene 2 LP: --- Groups: All (1-4)

* SP = Short press

** LP = Long press

Control via smartphone with the OSRAM BT Control App

- The user can switch and dim the light via smartphone.
- The user can tune the light via smartphone (Tunable White).
- The user can set a password to limit access.



5.2.1.4 Additional configuration options via the OSRAM BT Config App

The controller can be configured via smartphone with the OSRAM BT Config App.

The BT Config App configuration is not mandatory, but enables more flexibility to adapt the behavior to the requirements of the customer.



Important note:

After powering up the controller, it can be configured with the BT Config App **for two hours only (as long as no admin password is stored)**. After the two-hour delay time has expired, connecting to the controller with the BT Config App is blocked. The timer can be reset by power-cycling the controller. When an admin password is set, the access to the controller will no longer expire.

The following features are a selection of the most popular project-specific adaptations. There are also many additional settings which can be looked up in the app.

5.2.1.5 Password protection

When connecting to the OSRAM BT Config App for the first time, a window pops up where an admin password and the user password can be set.

If you want to add or change the password, follow the steps below:

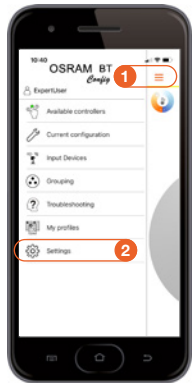

Set the admin/user password

1. Open the main menu.
2. Open “Settings”.
3. Open “Password”.
4. Enter an admin password to restrict the connection with the OSRAM BT Config App.

Please note: When the admin password is empty, you can only connect to the controller within two hours after connecting to mains. To reconnect after this time, you need to power-cycle the controller.

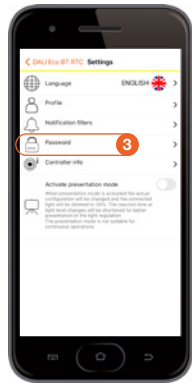

5. Enter a user password to restrict the connection with the OSRAM BT Control App.

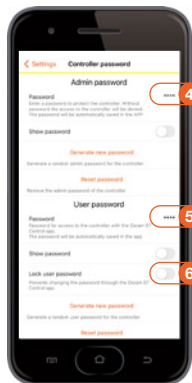

6. Enable “Lock user password” to restrict the change of the user password via the OSRAM BT Control App.

5.2.1.6 Switch-off delay time

The switch-off delay is the time after which the controller will leave the “on-state”. The switch-off delay timer is retriggered by each motion signal or manual user operation. The light will go **off** when no standby level is activated.

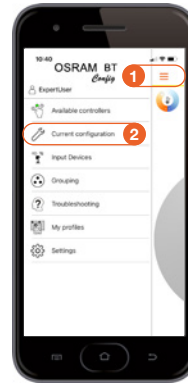

Change the switch-off delay time

1. Open the main menu.
2. Open “Current configuration”.
3. Open “Motion detection”.

Change the switch-off delay time according to your preferences.

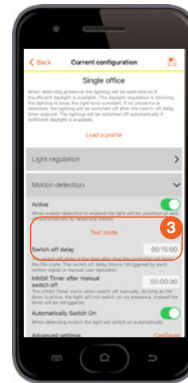

5.2.1.7 Standby level and time

When activated, the light will go to the standby level after the switch-off delay time has expired. The light will switch **off** after the standby time has expired.

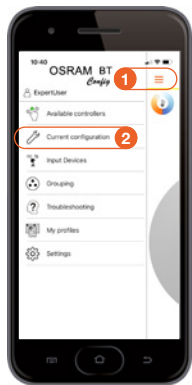

Activate the standby level and time

1. Open the main menu.
2. Open “Current configuration”.
3. Open “Advanced settings”.

Activate standby level and define the standby level and standby time according to your needs.

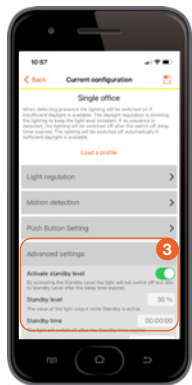

5.2.1.8 PIR inhibit timer after manual switch-off

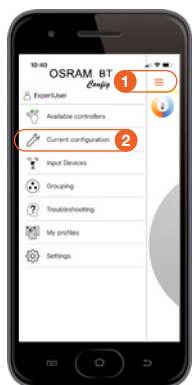

Change the PIR inhibit timer

1. Open the main menu.
2. Open “Current configuration”.
3. Open “Motion detection”.

Change the inhibit timer after manual switch-off.

The timer starts when manually switched off via pushbutton or app. As long as the timer is active, the presence sensor will not switch on the light. Instead, it will retrigger the timer.

- Change the setting to 01:00:00 to be sure that the light will not switch on automatically when you come back.
- Leave it at 00:00:30 sec if you want the automatic switch-on to be active again after you have left the room.

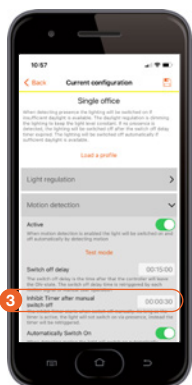

5.2.1.9 Manual setting of light regulation

Depending on the availability of natural daylight and the room setup, the light regulation value might need to be set manually – instead of automatically – to get the right amount of light according to customer needs.

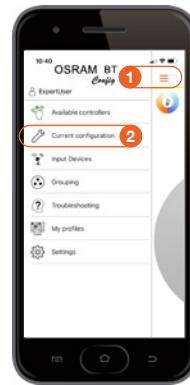

Manual setting of light regulation

1. Open the main menu.
2. Open “Current configuration”.
3. Now open the “Light regulation”.

4. Click on “Manual” to define the required light level manually.

5. Dim the light to the required level and use a lux meter to measure the amount of light directly at the place where the light is needed, e.g. a desk surface.

6. Click on “Save” to store the light level as a reference value for light regulation.

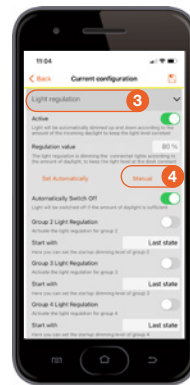

5.2.1.10 State after power failure

“State after power failure” defines the behavior of the connected DALI LED drivers after a power failure.

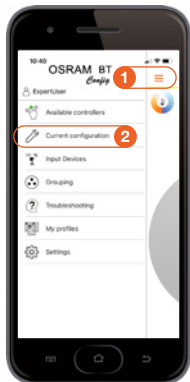

Change the state after power failure

1. Open the main menu.
2. Open “Current configuration”.
3. Open “Advanced settings”.

Change the **state after power failure** between **on/off/last state/standby** according to your needs.

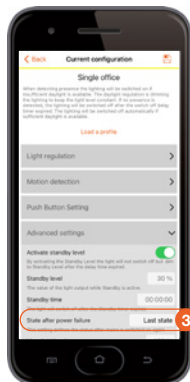

5.2.2 Meeting room with scene control

5.2.2.1 Requirements

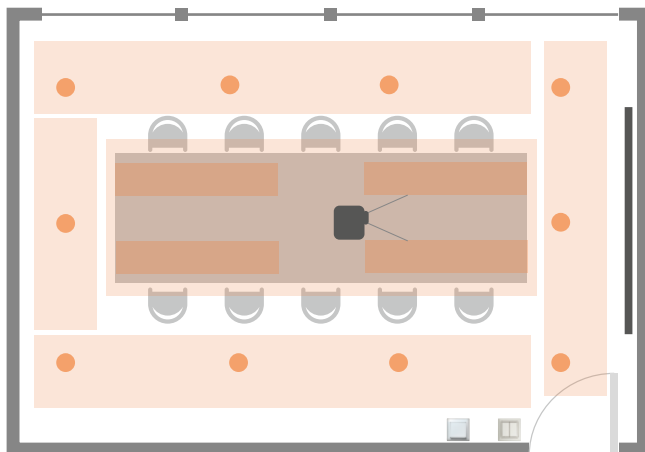

The meeting room luminaires can be switched and dimmed and pre-configured. Light scenes can be recalled by using pushbuttons.

The light will be switched on manually when a person enters the room, but automatically turned off by the sensor after a 15-minute delay time.

During presence, the daylight harvesting function will dim the artificial light up and down according to the amount of daylight available.

5.2.2.2 Application setup and wiring diagram

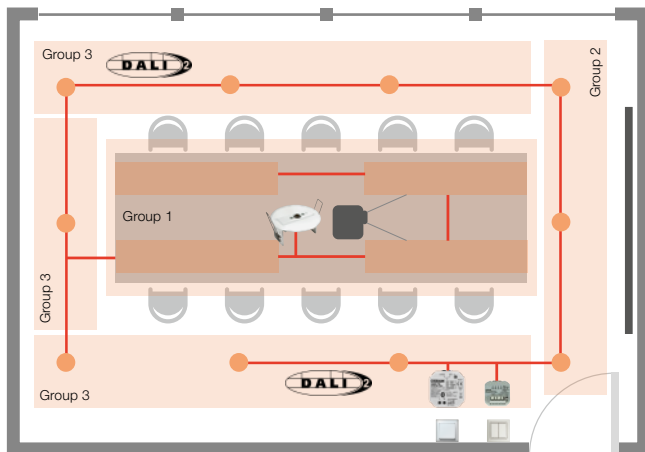

Solution with DALI ACU BT

1 x DALI LS/PD CI
Light and presence detector for ceiling integration



Standard DALI luminaires
4 x
10 x



1 x DALI ACU BT
DALI controller (best mounted in a flush box)



1 x DALI PRO PB coupler

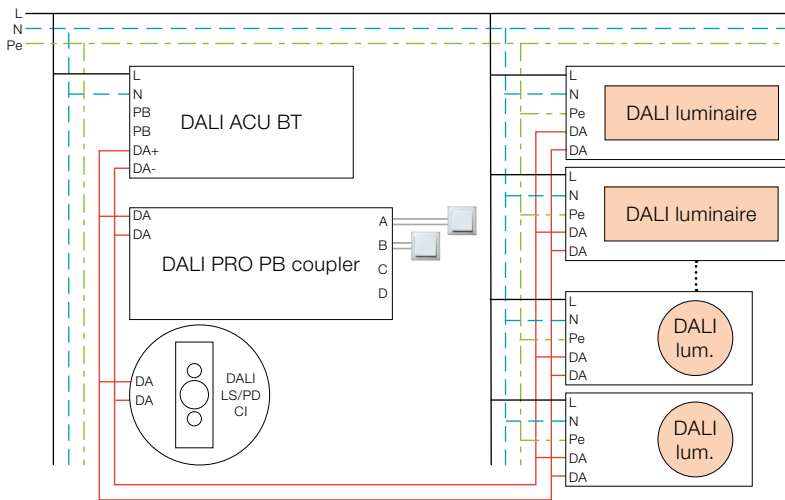

5.2.2.3 Out-of-the-box features (no app for configuration needed!)

Pushbutton coupler



Name	Function of input A	Function of input B	Function of input C	Function of input D
1: 1-channel Tunable White (default)	SP: Switch on/off LP: Dim up/down Groups: All (1-4)	SP: Toggle scene LP: Change color temp. Groups: All (1-4)	SP: Recall scene 1 LP: --- Groups: All (1-4)	SP: Recall scene 2 LP: --- Groups: All (1-4)

* SP = Short press

** LP = Long press

Control via smartphone with the OSRAM BT Control App

- The user can switch and dim the light via smartphone.
- The user can set a password to limit access.



4.2.2.4 Additional configuration options via the OSRAM BT Config App

The controller can be configured via smartphone with the OSRAM BT Config App.

The BT Config App configuration is not mandatory, but enables more flexibility to adapt the behavior to the requirements of the customer.

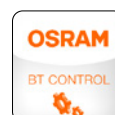

Important note

After powering up the controller, it can be configured with the BT Config App **for two hours only (as long as no admin password is stored)**. After the two-hour delay time has expired, connecting to the controller with the BT Config App is blocked. The timer can be reset by power-cycling the controller. When an admin password is set, the access to the controller will no longer expire.

The following features are a selection of the most popular project-specific adaptations. There are also many additional settings which can be looked up in the app.

5.2.2.5 Password protection

Please see 5.2.1.5: Password protection

5.2.2.6 Change of default setup

The default setup of the control unit is the “Single Office” mode, which needs to be changed to the “Meeting Room” mode first.

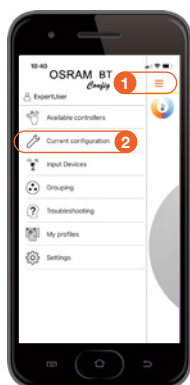

Change of default setup

1. Open the main menu.
2. Open “Current configuration”.
3. The “Single office” profile is activated by default.
4. Click on “Load a profile”.
5. Select the “Meeting room” profile and click on “OK” to save this change of configuration.

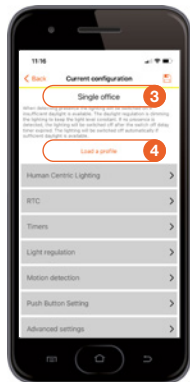

5.2.2.7 Grouping

According to the meeting room requirements, the luminaires need to be grouped to realize the setup for two different light scenes: “Meeting” and “Presentation”.

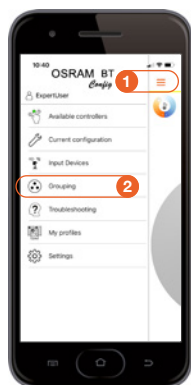

Group the luminaires

1. Open the main menu.
2. Open “Grouping” in the main menu.
3. Start the addressing procedure by selecting “Activate Grouping”.
4. All found LED drivers will be listed and automatically assigned to group 1.

After selecting one device, the connected luminaire starts flashing.



5. After selecting the group number, the number changes 1-2-3-4-1 ..., as up to four groups can be configured.

- Group 1 = Table light
- Group 2 = Projector wall light
- Group 3 = Surrounding light

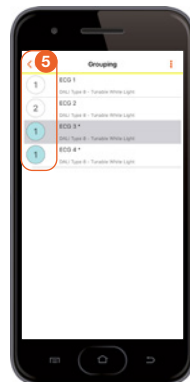
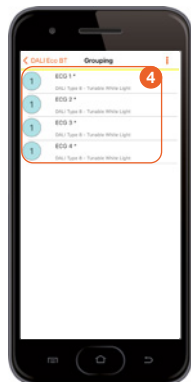

5.2.2.8 Scene creation

The meeting room light should be able to change just by clicking on a pushbutton, based on two different lighting scenarios: “Meeting” and “Presentation”.

Scene 1: Meeting

- Recall via pushbutton
- Light level group 1: 80 %
- Light level group 2: 50 %
- Light level group 3: 50 %

Scene 2: Presentation

- Recall via pushbutton
- Light level group 1: 50 %
- Light level group 2: 0 %
- Light level group 3: 30 %

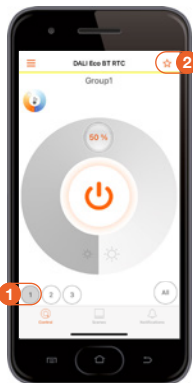

Create the scenes

Go to the **control menu** and start with **scene 1**:

1. Click on “Group 1” and dim the light to the required level (group 1 = 80 %).

Repeat this step for “Group 2” (50 %) and “Group 3” (50 %).

2. Click on the “star” to save this scenario as **scene 1 = “Meeting” for group 1 (80 %), group 2 (50 %) and group 3 (50 %).**

Repeat these steps for “Scene 2” = Presentation

3. Open the scene menu to activate the stored scenes or press the buttons 3 and 4 on the pushbutton coupler.

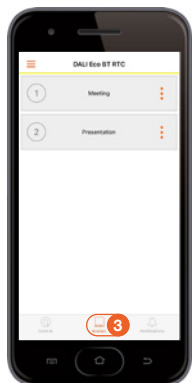

5.2.3 Classroom with daylight harvesting (DLHV) plus light group offset

5.2.3.1 Requirements

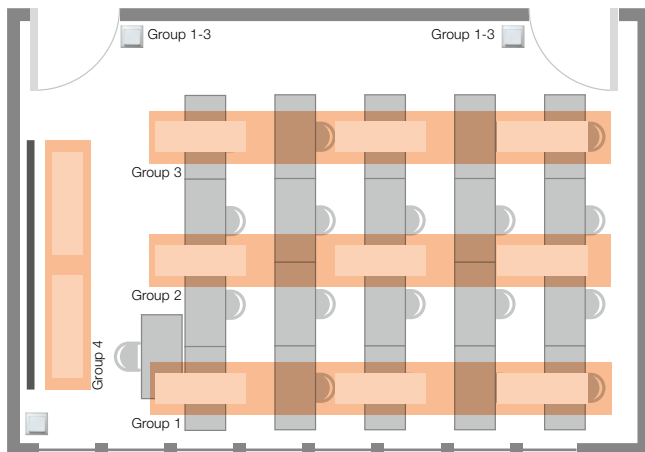

The classroom luminaires are divided into four light groups. Group 4 (presentation board) can be switched and dimmed separately.

The lights will be switched on manually when a person enters the room, but automatically turned off after a 15-minute delay time if no presence is detected.

During presence, the daylight harvesting function will dim the artificial light up and down according to the amount of daylight available.

5.2.3.2 Application setup and wiring diagram

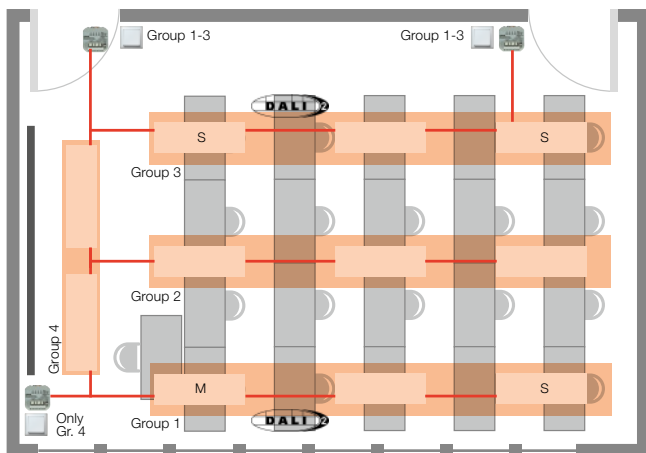

Solution with DALI ECO BT

3 x DALI PRO PB coupler

7 x standard DALI luminaires

M = Master luminaire

1 x DALI luminaire with integrated DALI ECO BT Control device and DALI LS/PD LI sensor

S = Sensor luminaire

3 x DALI luminaire with integrated DALI LS/PD LI sensor

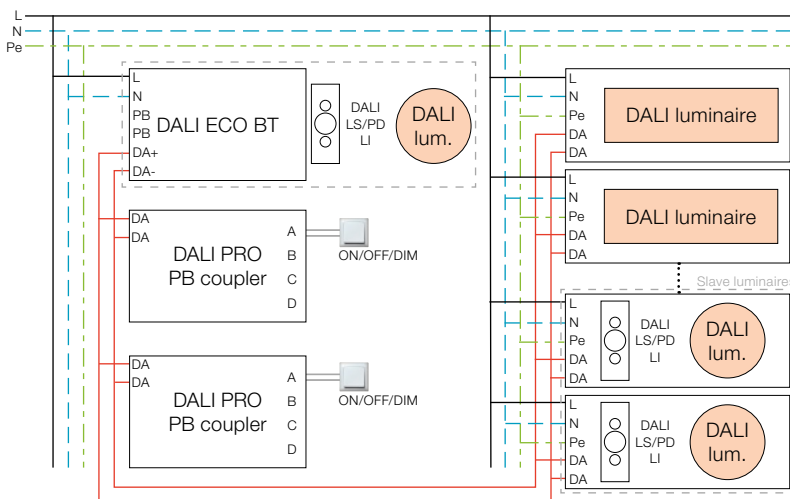
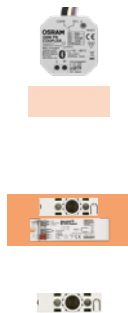

5.2.3.3 Out-of-the-box features (no app for configuration needed!)

Attention: For this application, the out-of-the-box features are **not** sufficient.

Additional configuration via the **OSRAM BT Config App** is required (see chapter 5.2.3.4 ff.)

5.2.3.4 Configuration via the OSRAM BT Config App

The controller can be configured via smartphone with the OSRAM BT Config App.

The BT Config App configuration is **mandatory** for this application!

The grouping feature needs to be activated, the HCL function needs to be deactivated and the two pushbuttons need to be configured as well.



Important note:

After powering up the controller, it can be configured with the BT Config App **for two hours only (as long as no admin password is stored)**. After the two-hour delay time has expired, connecting to the controller with the BT Config App is blocked. The timer can be reset by power-cycling the controller. When an admin password is set, the access to the controller will no longer expire.

The following features are a selection of the most popular project-specific adaptations. There are also many additional settings which can be looked up in the app.

5.2.3.5 Password protection

Please see 4.2.1.5: Password protection

5.2.3.6 Activation of semi-automatic mode (manually on, automatically off)

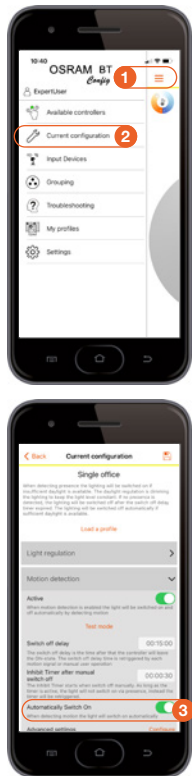

Activation of semi-automatic mode

1. Open the main menu.
2. Open “Current configuration”.
3. Open “Motion detection”.
4. Move the “Automatically Switch On” slider to off.

The presence sensor will not switch on the light automatically while detecting presence, the light needs to be switched on manually via the pushbutton.

5.2.3.7 Grouping

According to the classroom requirements, the luminaires need to be grouped to realize the four different light groups.



Group the luminaires

1. Open the main menu.
 2. Open “Grouping” in the main menu.
 3. Start the addressing procedure by selecting “Activate Grouping”.
 4. All found LED drivers will be listed and automatically assigned to group 1.
- After selecting a device, the connected luminaire starts flashing.
5. After selecting the group number, the number changes 1-2-3-4-1 ..., as up to four groups can be configured.

- Group 1 = Window row light
- Group 2 = Center row light
- Group 3 = Inner row light
- Group 4 = Presentation board light



5.2.3.8 DLHV function with defined light group offset

Depending on the availability of natural daylight and the room setup, the light regulation provides the right amount of light according to the needs of the customer. As the DLHV function is dedicated to group 1 only, the other light groups – group 2 and group 3 – have to be run with a defined offset compared to group 1 to guarantee an equal light distribution throughout the room.

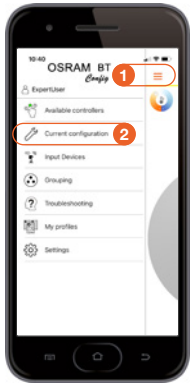

Define the light group offset

1. Open the main menu.
2. Open “Current configuration”.
3. Now open the “Light regulation”.
4. Activate the “Group 2 Light Regulation” and define the “Offset” according to room requirements.

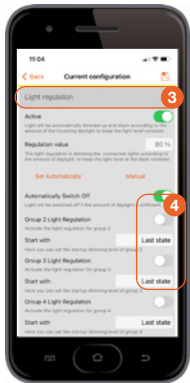

Repeat step 4 for the “Group 3 Light Regulation” setup.

5.2.3.9 Change of pushbutton coupler (PBC) setting for group 4 (presentation board)

The default setup of all PBCs is “1: 1-channel Tunable White”. As only **group 4 (presentation board)** has a dedicated pushbutton for separate control, only the dedicated PBC setup needs to be changed to “4: 4-channel dimming”. The pushbutton needs to be connected to **input D** on the dedicated PBC.

Name	Function of input A	Function of input B	Function of input C	Function of input D
1: 1-channel Tunable White (default)	SP*: Switch on/off LP**: Dim up/down Groups: All (1–4)	SP: Toggle scene LP: Change color temp. Groups: All (1–4)	SP: Recall scene 1 LP: --- Groups: All (1–4)	SP: Recall scene 2 LP: --- Groups: All (1–4)
2: 2-channel Tunable White	SP: Switch on/off LP: Dim up/down Group: 1	SP: Switch on/off LP: Dim up/down Group: 2	SP: --- LP: Change color temp. Group: 1	SP: --- LP: Change color temp. Group: 2
3: 2-channel dimming	SP: Switch on/off LP: Dim up/down Group: 1	SP: Switch on/off LP: Dim up/down Group: 2	SP: On LP: --- Groups: All (1–4)	SP: Off LP: --- Groups: All (1–4)
4: 4-channel dimming	SP: Switch on/off LP: Dim up/down Group: 1	SP: Switch on/off LP: Dim up/down Group: 2	SP: Switch on/off LP: Dim up/down Group: 3	SP: Switch on/off LP: Dim up/down Group: 4
5: Scene control	SP: Recall scene 1 LP: --- Groups: All (1–4)	SP: Recall scene 2 LP: --- Groups: All (1–4)	SP: Recall scene 3 LP: --- Groups: All (1–4)	SP: Recall scene 4 LP: --- Groups: All (1–4)
6: 1-group Tunable White and HCL¹⁾	SP: Switch on/off LP: Dim up/down Groups: All (1–4)	SP: --- LP: Change color temp. Groups: All (1–4)	SP: Recall scene 1 LP: --- Groups: All (1–4)	SP: HCL resume LP: --- Groups: All (1–4)

¹⁾ HCL only applicable with DALI ECO BT RTC Control device

* SP = Short press

** LP = Long press

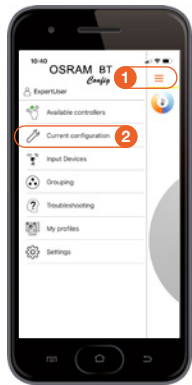

Change of default setup for group 4

1. Open the main menu.
2. Open “Current configuration”.
3. Open “Push Button Setting” and click on “Configure” for the “Push Button Coupler”.
4. Please identify the dedicated PBC of group 4 by pressing the connected pushbutton.

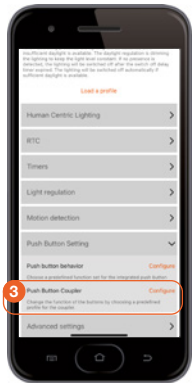

5. Select the “4. DIM – 4 groups” profile and click on “Done” to save this change of configuration.



5.2.4 Corridor including standby (infinite timer)

5.2.4.1 Requirements

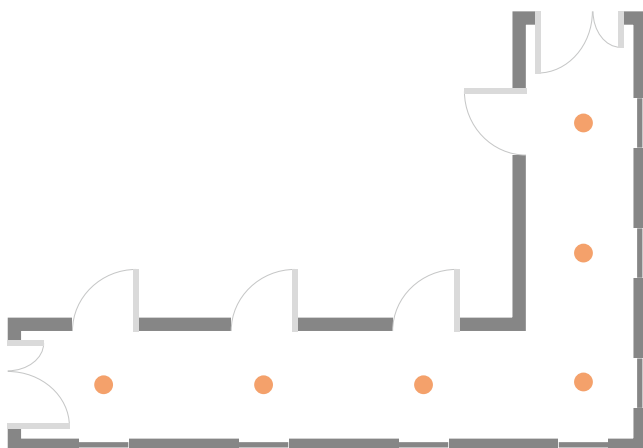

The lights will be switched on automatically when a person enters the corridor and automatically dimmed down to a light level of 10 % after the delay time has expired and if no presence is detected.

The light will stay on and never switch off due to safety requirements, so the standby time is infinite.

5.2.4.2 Application setup and wiring diagram

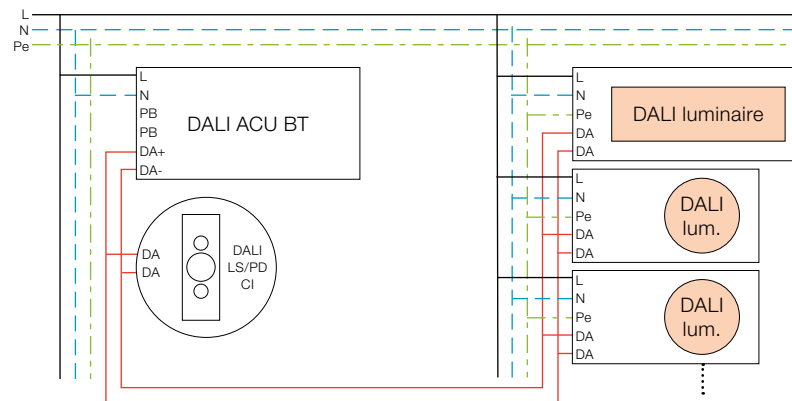
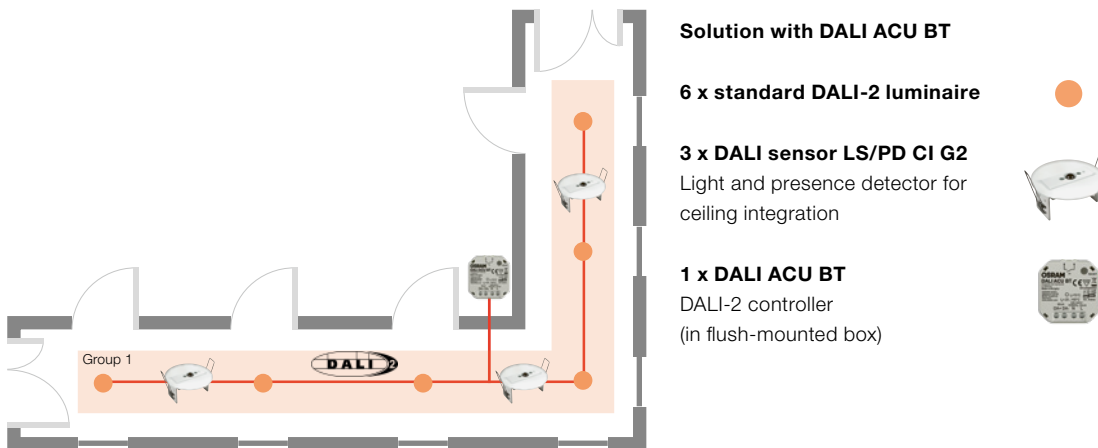

5.2.4.3 Out-of-the-box features (no app for configuration needed!)

Attention: For this application, the out-of-the-box features are **not** sufficient.

Additional configuration via the **OSRAM BT Config App** is required (see chapter 5.2.3.4 ff.)!

5.2.4.4 Configuration via the OSRAM BT Config App

The controller can be configured via smartphone with the OSRAM BT Config App.

The BT Config App configuration is **mandatory** for this application!

The grouping feature needs to be activated, the HCL function needs to be deactivated and the two pushbuttons need to be configured as well.



Important note:

After powering up the controller, it can be configured with the BT Config App **for two hours only (as long as no admin password is stored)**. After the two-hour delay time has expired, connecting to the controller with the BT Config App is blocked. The timer can be reset by power-cycling the controller. When an admin password is set, the access to the controller will no longer expire.

The following features are a selection of the most popular project-specific adaptations. There are also many additional settings which can be looked up in the app.

5.2.4.5 Password protection

Please see 4.2.1.5: Password protection

5.2.4.6 Change of default setup

The default setup of the control unit is the “Single Office” mode, which needs to be changed to the “Corridor” mode first.

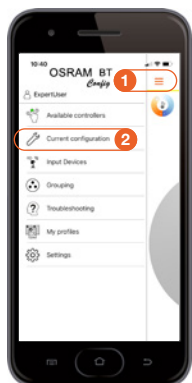

Change of default setup

1. Open the main menu.
2. Open “Current configuration”.
3. The “Single office” profile is activated by default.
4. Click on “Load a profile”.
5. Select the “Corridor” profile and click on “OK” to save this change of configuration.

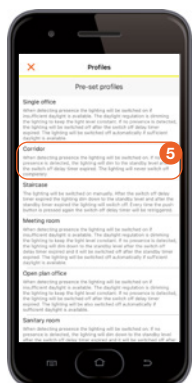
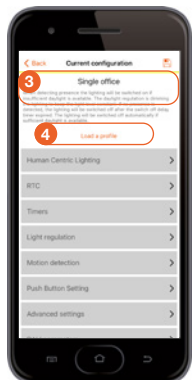

5.2.4.7 Standby level and time

When the “Corridor” mode is activated (see chapter 5.2.4.6), the light will go to the pre-defined standby level of 10 % after the switch-off delay time has expired. The light will never switch off as the standby time is infinite.

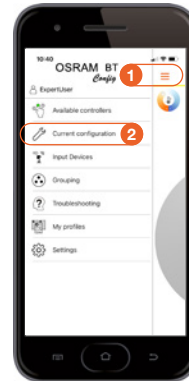

Choose the standby level

1. Open the main menu.
2. Open “Current configuration”.
3. Open “Advanced settings”.

Choose the required “Standby level”. The default level in “Corridor” mode is 10 %.

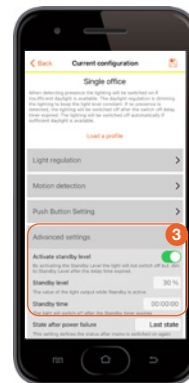

5.2.5 Open-plan office including standby

5.2.5.1 Requirements

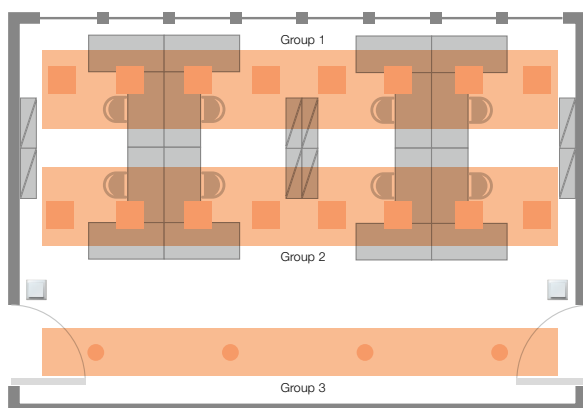

The open-plan office luminaires are divided into three light groups which can be switched and dimmed.

The lights will be switched on automatically when a person enters the room and dimmed down to a standby level after a 15-minute delay time if no presence is detected.

During presence, the daylight harvesting function will dim the artificial light up and down according to the amount of daylight available.

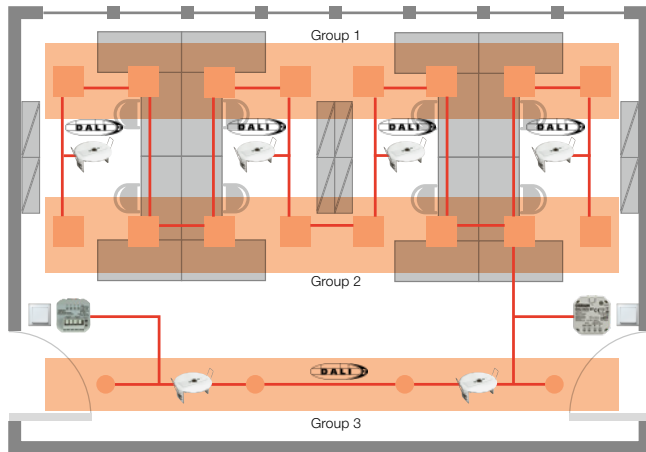

Solution with DALI ACU BT

1 x DALI ACU BT
DALI controller
(best mounted in a flush box)

Standard DALI luminaire
16 x
4 x

1 x DALI PRO PB coupler

6 x DALI LS/PB CI
Light and presence detector for ceiling integration

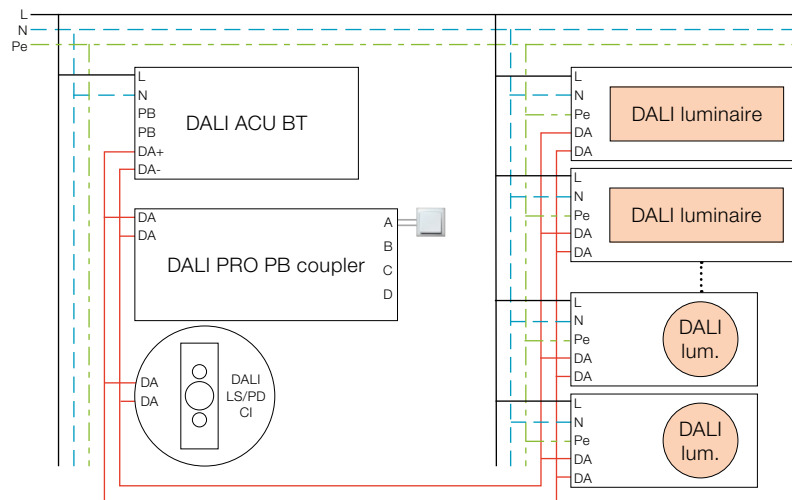

5.2.5.3 Out-of-the-box features (no app for configuration needed!)

Attention: For this application, the out-of-the-box features are **not** sufficient.

Additional configuration via the **OSRAM BT Config App** is required (see chapter 5.2.3.4 ff.)!

5.2.5.4 Configuration via the OSRAM BT Config App

The controller can be configured via smartphone with the OSRAM BT Config App.

The BT Config App configuration is **mandatory** for this application!

The grouping feature needs to be activated, the HCL function needs to be deactivated and the two pushbuttons need to be configured as well.



Important note:

After powering up the controller, it can be configured with the BT Config App for **two hours only (as long as no admin password is stored)**. After the two-hour delay time has expired, connecting to the controller with the BT Config App is blocked. The timer can be reset by power-cycling the controller. When an admin password is set, the access to the controller will no longer expire.

The following features are a selection of the most popular project-specific adaptations. There are also many additional settings which can be looked up in the app.

5.2.5.5 Password protection

Please see 5.2.1.5: Password protection

5.2.5.6 Change of default setup

The default setup of the control unit is the “Single Office” mode, which needs to be changed to the “Open-plan office” mode first.

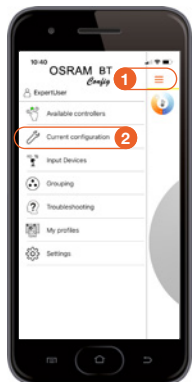

Change of default setup

1. Open the main menu.
2. Open “Current configuration”.
3. The “Single office” profile is activated by default.
4. Click on “Load a profile”.
5. Select the “Open-plan office” profile and click on “OK” to save this change of configuration.

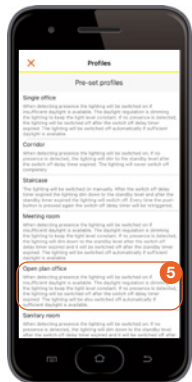
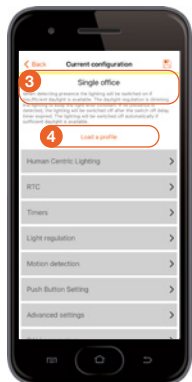

5.2.5.7 Standby level and time

When the “Open-plan office” mode is activated (see chapter 5.2.5.6), the light will go to the pre-defined standby level of 30 % after the switch-off delay time has expired. The light will switch off after one hour if no presence is detected during the standby time.

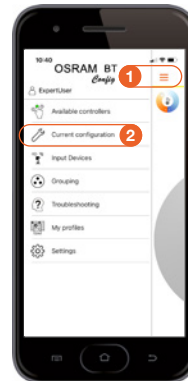

Choose the standby level and time

1. Open the main menu.
2. Open “Current configuration”.
1. Open “Advanced settings”.

Choose the required “Standby level” and “Standby time”.

Default values in “Open-plan office” mode:

- Standby level = 30 %
- Standby time = 1 hour

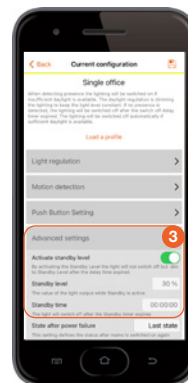

5.2.5.8 Grouping

According to the open-plan office requirements, the luminaires need to be grouped to realize the three different light groups.

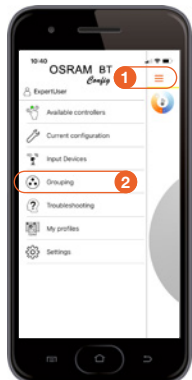

Group the luminaires

1. Open the main menu.
2. Open “Grouping” in the main menu.
3. Start the addressing procedure by selecting “Activate Grouping”.
4. All found LED drivers will be listed and automatically assigned to group 1.

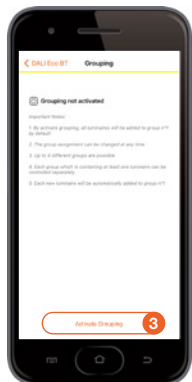

After selecting a device, the connected luminaire starts flashing.

5. After selecting the group number, the number changes 1-2-3-4-1 ..., as up to four groups can be configured.

- Group 1 = Window row light
- Group 2 = Center row light
- Group 3 = Corridor row light

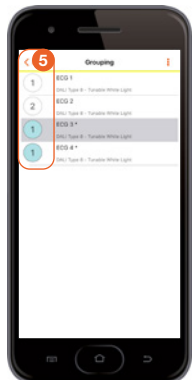
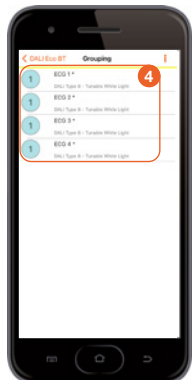

5.2.5.9 DLHV function with defined light group offset

Depending on the availability of natural daylight and the room setup, the light regulation provides the right amount of light according to the needs of the customer. As the DLHV function is dedicated to group 1 only, the other light groups – group 2 and group 3 – have to be run with a defined offset compared to group 1 to guarantee an equal light distribution throughout the room.

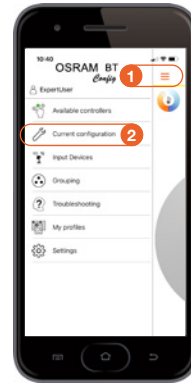

Define the light group offset

1. Open the main menu.
2. Open “Current configuration”.
3. Now open the “Light regulation”.
4. Activate the “Group 2 Light Regulation” and define the “Offset” according to room requirements.

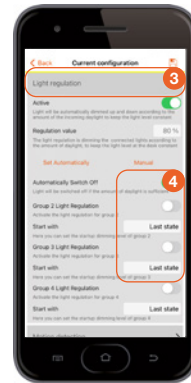

Repeat step 4 for the “Group 3 Light Regulation” setup.

5.2.6 Open-plan office including Swarm function

5.2.6.1 Requirements

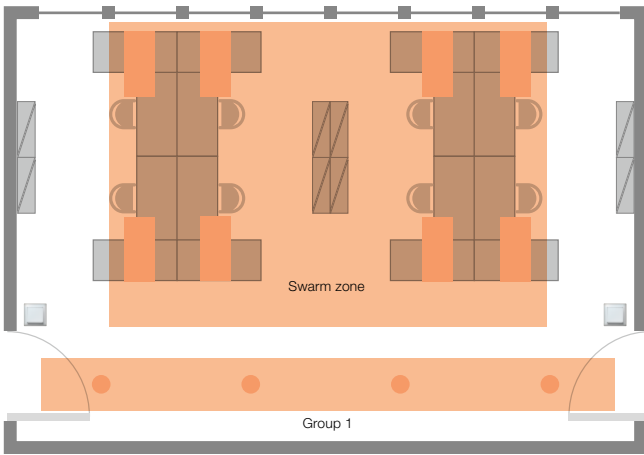

The open-plan office luminaires are floor-standing luminaires in the desk area and downlights in the corridor area. The desk luminaires are wirelessly interconnected and react as a big swarm as soon as presence is detected by one of the Swarm luminaires.

The lights will be switched on automatically when a person enters the Swarm zone. If no presence is detected anymore, the lights will be dimmed down to standby level after a 15-minute delay time.

During presence, the daylight harvesting function will dim the artificial light up and down according to the amount of daylight available.

5.2.6.2 Application setup and wiring diagram

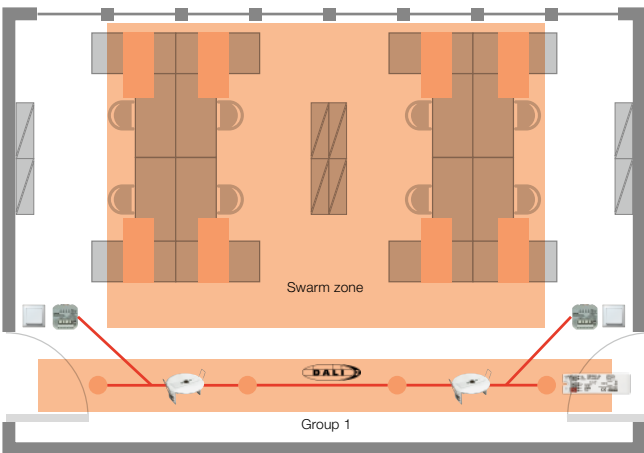

Solution with DALI ECO BT

8 x floor-standing DALI luminaire

DALI luminaire with integrated DALI ECO BT Control device and DALI LS/PD LI sensor

4 x standard DALI luminaire

1 x DALI ECO BT

2 x DALI PRO PB coupler

2 x DALI LS/PD CI

Light and presence detector for ceiling integration



a) Wiring diagram of floor-standing luminaires shown in the Swarm zone

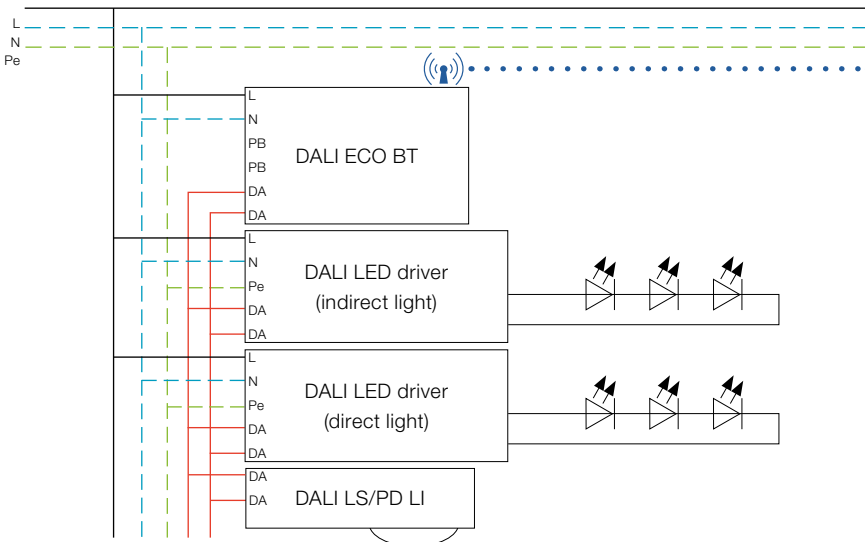

b) Wiring diagram of group 1 with standard DALI luminaires

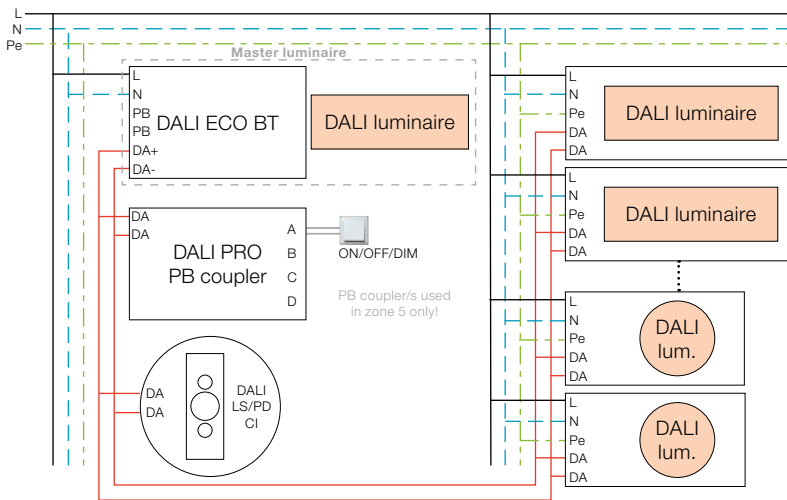

5.2.6.3 Out-of-the-box features (no app for configuration needed!)

Attention: For this application, the out-of-the-box features are **not** sufficient.

Additional configuration via the **OSRAM BT Config App** is required (see chapter 5.2.6.4 ff.)!

5.2.6.4 Configuration via the OSRAM BT Config App

The controller can be configured via smartphone with the OSRAM BT Config App.

The BT Config App configuration is **mandatory** for this application!



The grouping feature needs to be activated, the HCL function needs to be deactivated and the two pushbuttons need to be configured as well.

Important note:

After powering up the controller, it can be configured with the BT Config App **for two hours only (as long as no admin password is stored)**. After the two-hour delay time has expired, connecting to the controller with the BT Config App is blocked. The timer can be reset by power-cycling the controller. When an admin password is set, the access to the controller will no longer expire.

The following features are a selection of the most popular project-specific adaptations. There are also many additional settings which can be looked up in the app.

5.2.6.5 Password protection

Please see 5.2.1.5: Password protection

5.2.6.6 Activation of Swarm feature via Expert mode

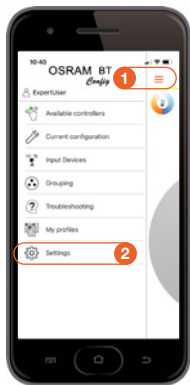

Activate the Swarm feature

Eight (8) BT Control devices in the Swarm zone need to be connected – one by one!

1. Open the main menu.
2. Open “Settings”.
3. Open “Profile”.

Please enter the following:

4. Name = **ExpertUser**
Company = **OSRAM**

5. Click on “Save”.

Go back to the main menu.

The profile change can now be identified by:

6. Name = **ExpertUser**
Additional function = **Diagnostic**

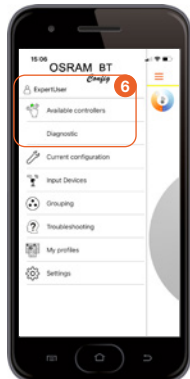
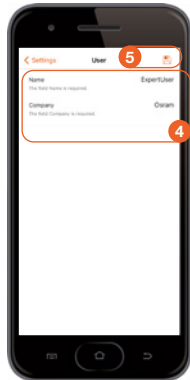
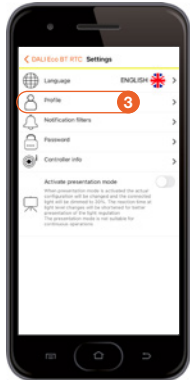

5.2.6.7 Swarm zone creation

Depending on the room setup, the independent desk luminaires can be integrated into a Swarm zone. A wireless information transfer between the luminaires is guaranteed due to the activated Swarm feature in each BT Control device. Each of the luminaires will switch on when presence is detected and all other Swarm luminaires will react accordingly.

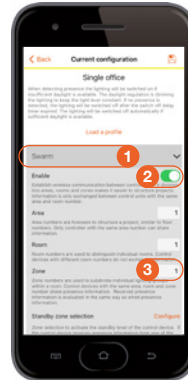

Create the Swarm zone/s

1. Open “Swarm”.
2. Enable the “Swarm function” for **this** BT Control.
3. Now check which **area, room and zone this** BT Control belongs to, as each of the **eight BT Control devices** needs to be in the same **Swarm zone**.

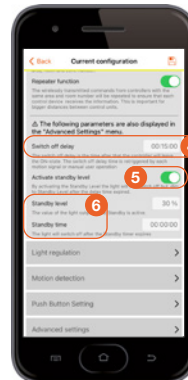

Important information:

- **System boundaries:**
 - Max. 20 participants in one zone
 - Max. 20 different zones
 - Max. 50 different rooms
 - Max. 50 different areas
- Presence information **can only be exchanged** between controllers with the **same area and room number**.

Now **scroll down** in the **Swarm menu**:

4. Check the “Switch off delay”.
5. Enable “Activate standby level”.
6. Define the “Standby level” and “Standby time” for **this** BT Control.

Attention: All BT Control devices linked in zone/s should have the same parameters programmed for an even and timely light distribution!

Important note:

As long as the **BT Control device is connected to the BT Config App**, the Swarm feature is **not working** because the Swarm connection is blocked by the app! Therefore, it is necessary to **disconnect the BT Config App first**. The **Swarm connection/s** between the BT controllers **will only be established afterwards**.

5.2.7 Open-plan office including Swarm function and zone division

5.2.7.1 Requirements

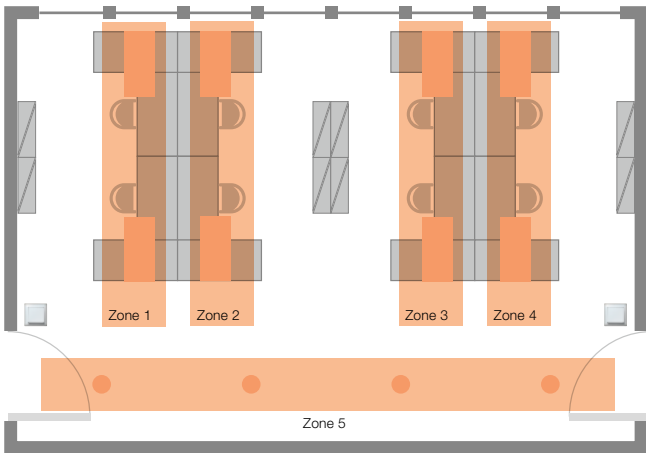

The open-plan office luminaires are floor-standing luminaires in the desk area and downlights in the corridor area. They are divided into five light zones.

The lights will be switched on automatically when a person enters a respective zone, while luminaires in linked zones will go to a pre-defined standby level. If no presence is detected anymore, the light will be dimmed down to standby level after a 15-minute delay time.

During presence, the daylight harvesting function will dim the artificial light up and down according to the amount of daylight available.

5.2.7.2 Application setup and wiring diagram

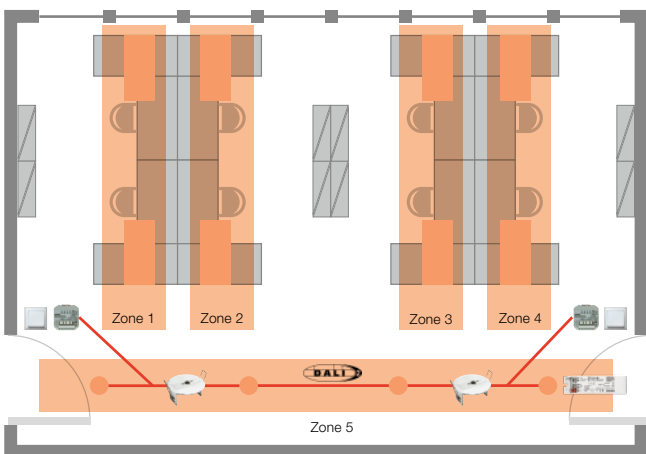

Solution with DALI ECO BT

8 x floor-standing DALI luminaire

DALI luminaire with integrated DALI ECO BT Control device and DALI LS/PD LI sensor

4 x standard DALI luminaire

1 x DALI ECO BT

2 x DALI PRO PB coupler

2 x DALI LS/PD CI

Light and presence detector for ceiling integration



c) Wiring diagram of floor-standing luminaires shown in zones 1-4

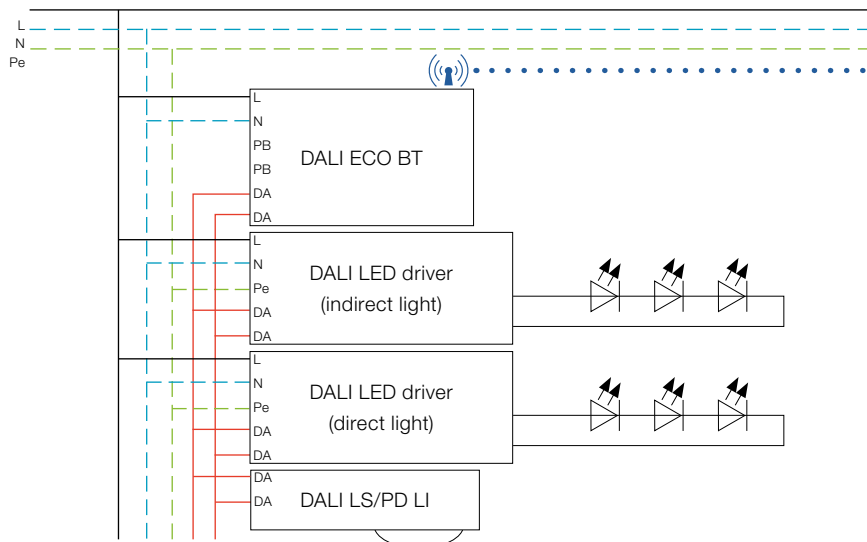

d) Wiring diagram of zone 5 with standard DALI luminaires

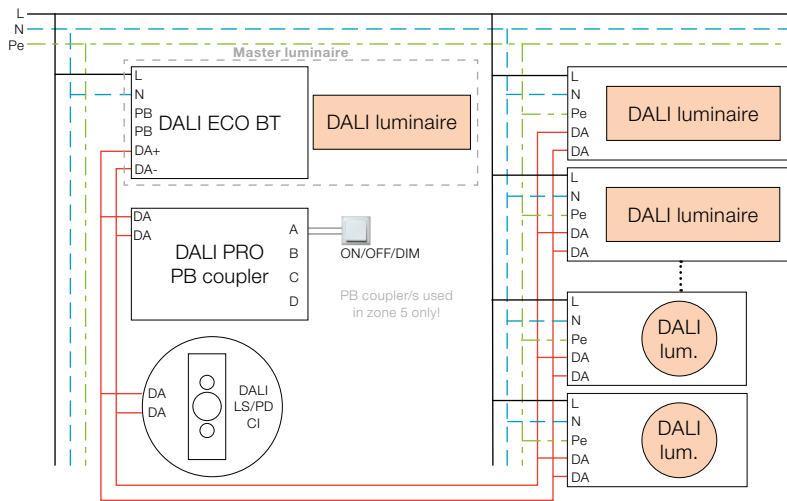

5.2.7.3 Out-of-the-box features (no app for configuration needed!)

Attention: For this application, the out-of-the-box features are **not** sufficient.

Additional configuration via the **OSRAM BT Config App** is required (see 5.2.5.4 ff.)!

5.2.7.4 Configuration via the OSRAM BT Config App

The controller can be configured via smartphone with the OSRAM BT Config App.

The BT Config App configuration is **mandatory** for this application!

The grouping feature needs to be activated, the HCL function needs to be deactivated and the two pushbuttons need to be configured as well.



Important note:

After powering up the controller, it can be configured with the BT Config App **for two hours only (as long as no admin password is stored)**. After the two-hour delay time has expired, connecting to the controller with the BT Config App is blocked. The timer can be reset by power-cycling the controller. When an admin password is set, the access to the controller will no longer expire.

The following features are a selection of the most popular project-specific adaptations. There are also many additional settings which can be looked up in the app.

5.2.7.5 Password protection

Please see 5.2.1.5: Password protection

5.2.7.6 Activation of Swarm feature via Expert mode

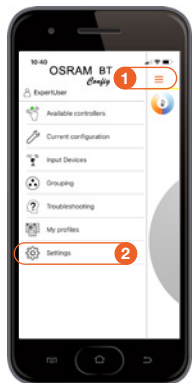

Activate the Swarm feature

Nine (9) BT Control devices need to be connected – one by one!

1. Open the main menu.
2. Open “Settings”.
3. Open “Profile”.

Please enter the following:

**4. Name = ExpertUser
Company = OSRAM**

5. Click on “Save”.

Go back to the main menu.

The profile change can now be identified by:

**6. Name = ExpertUser
Additional function = Diagnostic**

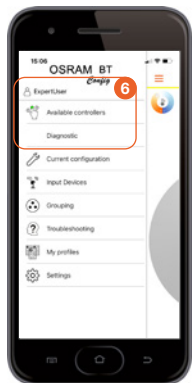
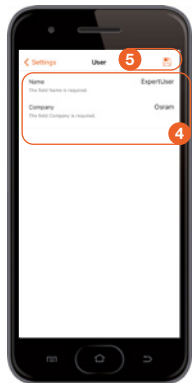
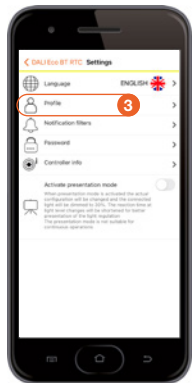

5.2.7.7 Creation of different Swarm zone/s

Depending on the room setup, the independent desk luminaires can be integrated into different light zones. A wireless information transfer between zones is guaranteed due to the activated Swarm feature in each BT Control device. Nevertheless, each of the zones will react independently and switch on their lights when presence is detected. Additionally, lights in other zone/s can react as well, according to the configuration for each of the linked zones.



Create the Swarm zone/s

1. Open “Swarm”.

2. Enable the “Swarm function” for **this** BT Control.

3. Now choose which **zone (1 to 5)** **this** BT Control belongs to, as each of the **nine BT Control devices** needs to be in **different zone/s** for standby feature.

4. Click on “Configure” in “Standby zone selection”.



5. Define the **standby zone/s** for **this** BT Control.

Important information:

- System boundaries:
 - Max. 20 participants in one zone
 - Max. 20 different zones
 - Max. 50 different rooms
 - Max. 50 different areas
- Presence information **can only be exchanged** between controllers with the **same area and room number**.

- Configuration of standby zone/s: The standby zone/s are the zone/s which go into standby mode while **this** BT Control is triggered by presence detected!

For example: This BT Control is in **zone 4**. The standby zone/s triggered by presence detection of **this** BT Control can be freely chosen – e.g. zone 5 only or zones 3 and 5 or even **all** other zones, meaning zones 1, 2, 3 and 5.

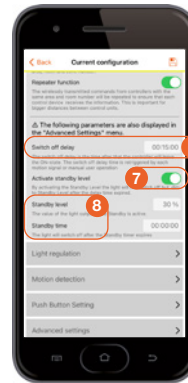

Now **scroll down** in the **Swarm** menu:

6. Check the “Switch off delay”.

7. Enable “Activate standby level”.

8. Define the “Standby level” and “Standby time” for **this** BT Control.

Attention: All BT Control devices linked in zone/s should have the same parameters programmed for an even and timely light distribution!

Important note:

As long as the **BT Control device is connected to the OSRAM BT Config App**, the Swarm feature is **not working** because the Swarm connection is blocked by the app! Therefore, it is necessary to **disconnect the OSRAM BT Config App first**. The **Swarm connection/s** between the BT controllers **will only be established afterwards**.

OSRAM GmbH
Headquarters Germany
Phone: +49 89 6213-0
E-mail: contact@osram.com

OSRAM a.s Office Austria
Phone: +43 1 250 24
E-mail: info@osram.at

OSRAM Benelux B.V.
Netherlands
Phone: +31 (0) 88 750 8800
E-mail: osram@osram.nl

Belgium
Phone: +32 (0) 2 588 49 51
E-mail: osram@osram.be

OSRAM Sales EOOD Bulgaria
Phone: +359 32 348 110
E-mail: sales-sofia@osram.com

OSRAM d.o.o. Croatia
Phone: +385 1 3032-023
E-mail: osram@osram.hr

OSRAM Ceska republika s.r.o.
Czech Republic
Phone: +42 0 554 793 111
E-mail: osram@osram.cz

OSRAM A/S Denmark
Phone: +45 43 30 20 40

OSRAM Oy Finland
Phone: +358 9 8493 2200
E-mail: asiakaspalvelu@osram.fi

Baltic DS/OSRAM Oy Finland:
Estonia, Latvia and Lithuania
Phone: +358 9 8493 2200
E-mail: customerservice@osram.fi

OSRAM Lighting Middle East FZE
Dubai – United Arab Emirates
Phone: +971 4 523 1777
E-mail: ds-mea@osram.com

OSRAM Lighting SASU France
Phone: +33 3 68 41 89 33
E-mail: oem@osram.fr

OSRAM Limited Great Britain
Phone: +44 1925 273 360
E-mail: oem@osram.com

OSRAM a.s. Magyarországi
Fióktelepe Hungary
Phone: +36 1 225 30 55
E-mail: info@osram.hu

OSRAM SpA Società Riunite
OSRAM Edison Clerici Italy
Phone: +39 02 424 91
E-mail: oemcentroservizi@osram.com

OSRAM Lighting AS Norway
Phone: +47 40 00 40 14

OSRAM North Africa S.a.r.l.
E-mail: contact@osram.com

OSRAM (Pty.) Ltd. South Africa
Phone: +27 10 221 40 00

OSRAM Sp. z.o.o. Poland
Phone: +48 22 376 57 00
E-mail: biuro.pl@osram.pl

OSRAM LDA
Portugal, Açores, Madeira
Phone: +351 21 033 22 10
E-mail: osram@osram.pt

OSRAM OOO Russia DS
Phone: +7 (499) 649-7070
E-mail: ds-russia@osram.com

OSRAM Romania S.R.L.
Phone: +40 (21) 232 85 61
E-mail: osram_ro@osram.com

OSRAM, a.s. Slovak Republic
Phone: +421 35 64 64 473
E-mail: contact@osram.com

OSRAM a.s. Slovenia
Phone: +43 1 250 24
E-mail: info@osram.at

OSRAM Lighting S.L. Spain
Phone: +34 91 491 52 17
E-mail: marketing-ds@osram.com

OSRAM AB Sweden
Phone: +46 128 70 400
E-mail: info@osram.se

OSRAM Lighting AG Switzerland
Phone: +41 52 555 25 55
E-mail: info.ch@osram.com

OSRAM Teknolojileri Ticaret A.S.
Turkey
Phone: +90 212 703 43 00
E-mail: contact@osram.com

OSRAM Sales Greece
Phone: +30 21 309 940 36
E-mail: greece@osram.com

OSRAM GmbH

Headquarters Germany:

Marcel-Breuer-Strasse 6
80807 Munich, Germany
Phone +49 89 6213-0
Fax +49 89 6213-2020
www.osram.com

OSRAM