



# Ensto One Home

## for single family houses

Ensto One Home makes your EV charging easy, safe and smart. Elegant and durable charging unit is with fixed charging cable a key to super electric driving experience. Smart connectivity enables local load management solutions.

**3,6**  
kW

**7,4**  
kW

**11**  
kW

**22**  
kW



"Super Electric  
Charging at Home!"



"Plug-in or full EV,  
Ensto One Home is  
your choice!"

# My home is my castle

Experience the future of charging at home

EVs or PHEVs spend most of their time at home, just like you. Ensto One Home is the easy and safe way to charge your car while you can concentrate on other, more important matters. Ensto One Home ensures the Super Electric Driving Experience.

### SUPER EASY INSTALLING

Ensto One Home is easy and fast to install on the wall or on dedicated Ensto One pole. It's also super fast to get ready, Ensto Charger Control app enables adjusting charging current if needed and that's it!

### SUPER EASY CHARGING

Ensto One Home is always equipped with fixed 5-meter charging cable and Type 2 plug. When not in use, plug rests gently in the middle of the indicator ring. Super easy, right?

### SUPER SAFE CHARGING

Ensto One Home is designed according to latest standards concerning EV charging. It's made to last also in harsh weather conditions. Ensto One Home makes sure, that you're ready for your next super electric driving experience.

### SMART CHARGING

Ensto One Home has available new smart connection features for load management purposes. These features enable to adjust charging current and charging event based on building's total energy consumption.

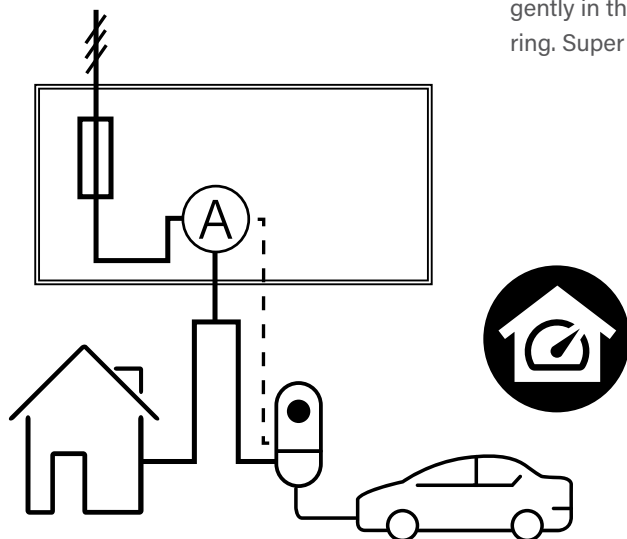

### WHY LOAD MANAGEMENT MAKES PERFECT FIT WITH EV CHARGING:

- Enables to install EV charger on homes with limited power capacity
- Helps to optimize the needed grid fuse size and costs
- Provides adjustable & dynamic charging operation

**STRUCTURE**

- Enclosures polycarbonate (PC) plastic
- IP54
- IK10
- Ambient temperature range -40...+50 °C

**INSTALLATION**

- Wall installation as a default, optionally available also pole adapter and full length pole
- 1-phase (L1, N, PE) or 3-phase (L1, L2, L3, N, PE) Cu 2.5-10 mm2
- Ensto Charger Control mobile app for adjusting max. static charging current from 6A-16A/32A or enabling optional load management features

**FEATURES**

- Fixed, 5 m cable with Type 2 plug and integrated plug holder
- Two current versions 16A and 32A, 1-phase or 3-phase
- Operating current adjustable from 6A-16A/32A
- Start/stop charging from the app if authorized operating mode is selected
- Built-in Residual Current Monitoring module for DC current leakage detection (RDC-DD, 6mA)
- Optionally also residual current operated circuit-breaker with integral overcurrent protection (RCBO, 30mA)
- Dynamic load management together with external energy meter (installed on distribution board) and Modbus cabling for communication
- Override mode with NO/NC input for connecting external control device to manage charging event (ON/OFF)
- Scheduling allows EV driver to schedule charging event based on most optimal time



EVTL55.00

EVTL57.00

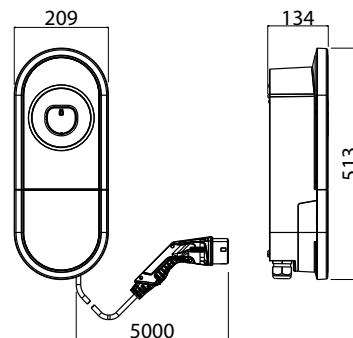





Product code	Technical name	Dynamic load management	Override	3,6 kW	7,4 kW	11 kW	22 kW	RCBO	
<b>Ensto One Home</b>									
EVH161B-HC000	Ensto One Home 1x16A Type2 cable IP54 DLM	yes*	yes**	x					
EVH321B-HC000	Ensto One Home 1x32A Type2 cable IP54 DLM	yes*	yes**		x				
EVH161B-HCR00	Ensto One Home 1x16A Type2 cable RCBO IP54 DLM	yes*	yes**	x				x	
EVH321B-HCR00	Ensto One Home 1x32A Type2 cable RCBO IP54 DLM	yes*	yes**		x			x	
EVH163B-HC000	Ensto One Home 3x16A Type2 cable IP54 DLM	yes*	yes**			x			
EVH163B-HCR00	Ensto One Home 3x16A Type2 cable RCBO IP54 DLM	yes*	yes**			x		x	
EVH323B-HC000	Ensto One Home 3x32A Type2 cable IP54 DLM	yes*	yes**				x		
EVH323B-HCR00	Ensto One Home 3x32A Type2 cable RCBO IP54 DLM	yes*	yes**				x	x	
<b>Supported energy meter models</b>									
Ensto One Home supported energy meter for dynamic load management. Please see supported models and details on installation instructions. Sold separately.									
<b>Installation accessories</b>							<b>Length</b>	<b>Height</b>	<b>Width</b>
EVTL55.00	Ensto One pole adapter, double-sided						73 mm	427 mm	170 mm
EVTL57.00	Ensto One full length pole, double-sided						73 mm	1298 mm	170 mm

\* Will require energy meter installed on distribution board and related Modbus cabling. See supported energy meter models.

\*\* Override mode for connecting external control device to manage charging event (ON/OFF). Requires external contact NO/NC signal and cabling.

# Ensto enables smart EV charging for everyone!

	HOME CHARGING			PUBLIC CHARGING	
	WORK CHARGING				
	ENSTO ONE HOME	ENSTO ONE	ENSTO WALLBOX	ENSTO PRO	ENSTO MEDIA
					
	Super easy and safe home charger. It's the One for you.	Easy and smart home charging at apartment buildings or shared parking.	Modular solution for single or dual EV charging. Compact and user-friendly design.	An easy-to-use, long lifetime AC charging station for public EV charging.	Uniquely combines EV charging and outdoor advertisement with its stunning digital display.
1-PHASE	x	x	x	x	x
3-PHASE	x	x	x	x	x
KW / OUTLET	3,6 / 7,4 / 11 / 22	3,6 / 7,4 / 11 / 22	22	22	22
SMART	Local load management	x <sup>3)</sup>	x	x	x
DATA CONNECTION	-	Ethernet	4G/LAN/Wifi	4G/LAN/Wifi	LAN/4G
FIXED CABLE	x	-	-	-	-
CABLE RELEASE	-	x	x	x	x
NEEDED RCD	A or built-in <sup>1)</sup>	built-in	A or built-in <sup>1)</sup>	built-in	built-in
CHARGING OUTLETS	1	1	1-2	2	2
USER CONTROL	x <sup>1)</sup>	x <sup>4)</sup>	x <sup>4)</sup>	x <sup>4)</sup>	x <sup>4)</sup>
LOAD MANAGEMENT	-	x <sup>2)</sup>	x	x	x
MID-METER	-	x	x	x	x

1) Charger Control app  
 2) Cloud based, internet access mandatory  
 3) Cloud-based OCPP communication for EV Operators  
 4) In-built RFID reader, EV Operator specific solutions via OCPP

