

# ENSTO

## Ensto One Home



**EN** Installation Manual



RAK131B\_EN  
2025-04-28  
© 2025 Legrand Finland Oy

# Contents

1. Safety instructions.....	3
2. Description of symbols.....	3
3. Abbreviations.....	4
4. Delivery contents.....	4
5. Mounting instructions.....	5
5.1. Before installation.....	5
5.2. Cable entries.....	6
5.3. Wall mounting.....	8
6. Electrical connections.....	10
6.1. Power supply.....	10
6.2. Load management connections.....	12
6.2.1. Energy meter.....	12
6.2.2. External control device.....	15
6.2.3. Dynamic Load Management (DLM).....	16
6.2.4. Load Management in Override mode.....	17
6.2.5. Control of charging in Override mode.....	18
7. Technical information.....	19
8. Code key.....	22
9. Installation / Commissioning checklist.....	23
10. Dimension drawing.....	24
11. Troubleshooting.....	25
12. Charger Control Application.....	26
12.1. Pro settings in the Charger Control Application.....	26
12.2. Charger Settings.....	26
12.2.1. Technical max. charging current.....	26
12.2.2. Overcurrent limit.....	26
12.2.3. Earthing System.....	27
12.2.4. Connected phases.....	27
12.2.5. Phase rotation (only 3-phase chargers).....	27
12.2.6. Start Self test.....	27
12.2.7. Factory Reset.....	27
12.3. Load Management Settings.....	27
12.3.1. Energy meter vendor.....	27
12.3.2. Offline current.....	27
12.3.3. Measurement posititon.....	27
12.3.4. Connectivity settings.....	27
12.3.5. External control (dry contact).....	27

# Installation Manual

## 1. Safety instructions



Electrically skilled person

- The installation must only be done by a qualified professional.
- Read this Installation Manual carefully before you start the installation work.
- Obey the instructions in this Installation Manual, and make sure that the installation complies with national safety regulations, installation methods and restrictions.
- The information provided in this Installation Manual in no way exempts the installer or user from responsibility to obey all applicable safety regulations.
- This Installation Manual is a part of the product and must be stored in a safe location so that it is available for future reference.



**WARNING**

*Danger of electric shock! Risk of fire!*

- *Improper installation can cause personal injury and property damage.*
- *Do not switch on the power supply before the installation work is completed.*

## 2. Description of symbols

	WARNING - Indicates a hazard with a medium level of risk which, if not avoided, could result in death or serious injury or considerable damage to the equipment.
	Electrically skilled person is a person with relevant education and experience to enable him or her to perceive risks and to avoid hazards that electricity can create.
	Identifier for plug and socket outlet AC / EN62196-2 / Type 2
	Load management

### 3. Abbreviations

Abbreviation	Description
DLM	Dynamic Load Management to limit charging current if needed to protect the main fuses
LED	Light Emitting Diode
MCB	Miniature Circuit Breaker, protects cables and equipment from over load and short circuits
RCBO	Residual current Circuit Breaker with Overcurrent protection
RCD	Residual Current Device, protects humans and animals from electric shock
RDC-DD	Residual Direct Current Detecting Device, protects humans and animals from electric shock
RS-485	Recommended Standard 485, standard defining the electrical characteristics of drivers and receivers for use in serial communications systems

### 4. Delivery contents

- EVH Charging station
- Cable gland M32/M25 (depending on the model)
- Installation Manual in English, other languages please see [www.legrand.com](http://www.legrand.com)
- Multilingual User Guide

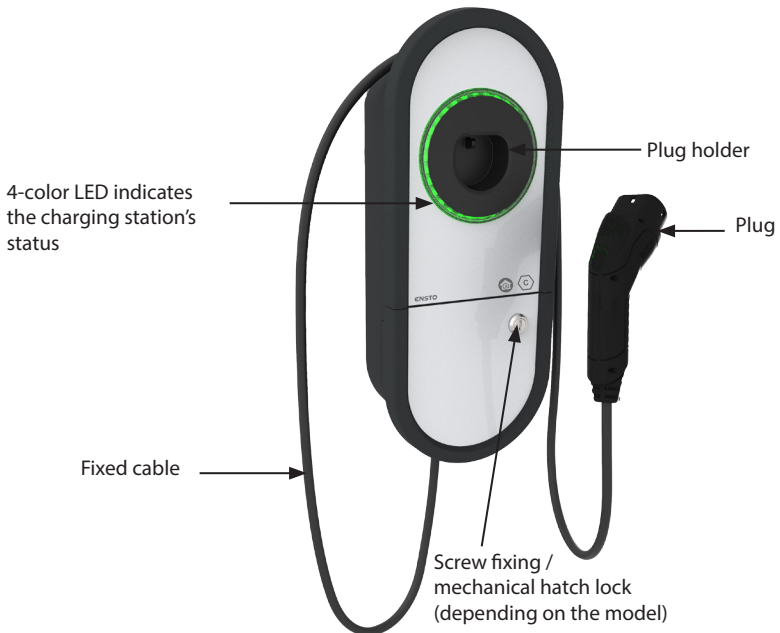

## 5. Mounting instructions

### 5.1. Before installation

Remove the charging station from its package. Do not scratch the surface of the charging station after removal from the package.

When selecting installation site, take into account the following:

- The charging station is applicable for indoor and outdoor use.
- To make sure the optimal charging performance, the charging station should not be exposed to direct sunlight.
- The minimum space necessary for operating and maintenance.

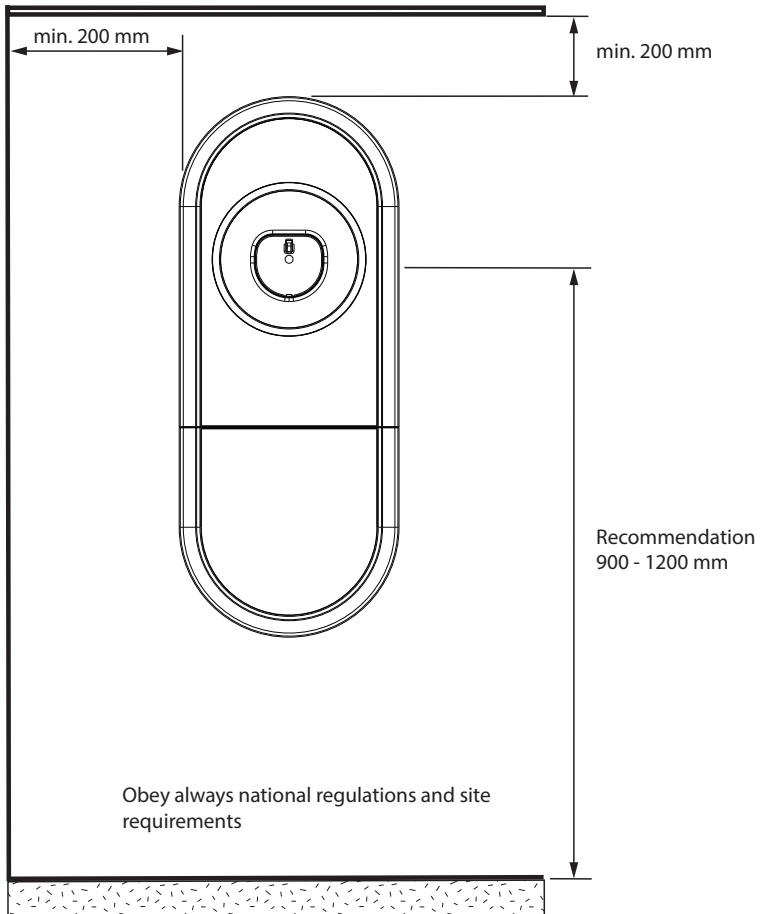

## 5.2. Cable entries

- Take the cable routing into consideration when planning the installation. The supply cable can be routed into the enclosure from the rear or bottom. Default cable routing is from the bottom.
- The M32 cable gland for the supply cable is pre-assembled on the bottom of the charging station.
- If it is necessary to open additional cable entries, you have to disassemble the charging station.

### Installation steps when cable routing is from alternative cable entries

1. Disassemble the charging station.

- 4** Remove the screws 5pcs.  
Remove the installation box from the base.

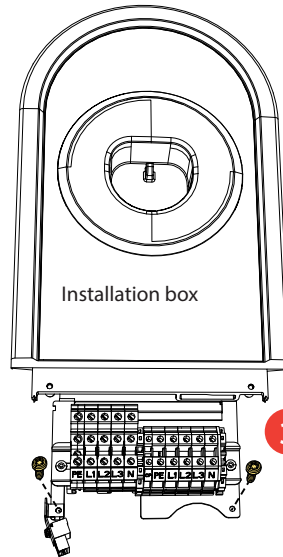
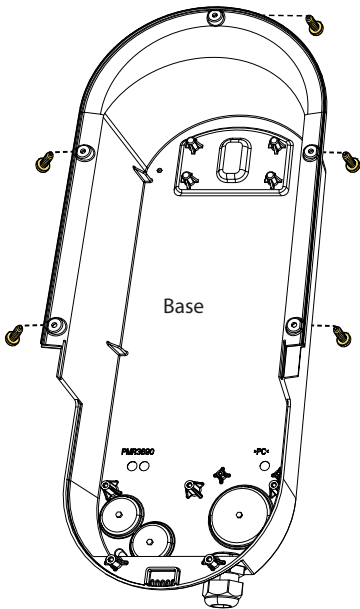

- 3** Remove the screws 2pcs.

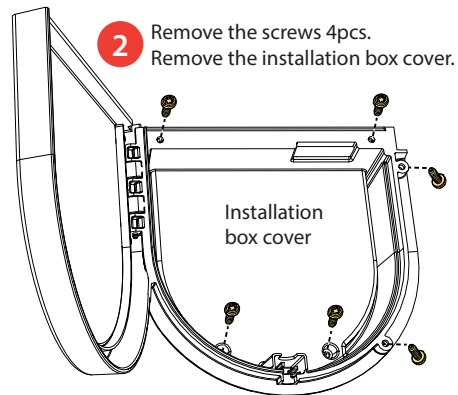

- 2** Remove the screws 4pcs.  
Remove the installation box cover.

- 1** Screw fixing: Remove the screws 2pcs.  
Mechanical lock: Unlock the hatch with a coin or suchlike.

2. Open the necessary cable entries with a step drill bit. M16 cable entries are applicable for the RS-485 or dry contact cabling.
3. Prepare the cable entries with applicable accessories.
4. Remove the included cable gland from the bottom and close the cable entry with a cover plug, PMR1217.32B (accessory).
5. Assemble the base and insert.
6. Assemble also the installation box cover, if electrical cables are installed in a separate session.

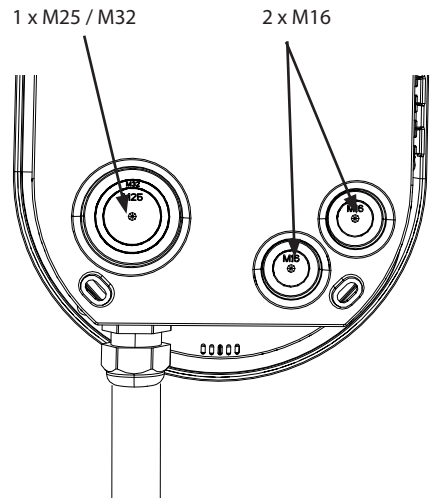
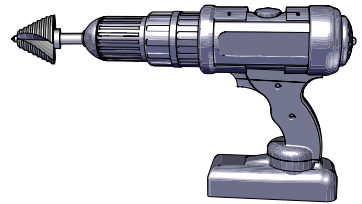
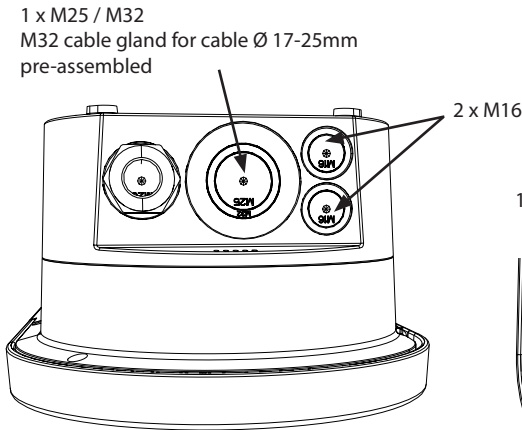

Accessories		
Part number	Description	Note
PMR1217.32B	Black cover plug for M32 opening	
KTM24.25/BLACK	M25 cable gland for cable Ø 10 - 16mm	EVH16...: included 1pc
PMR1219.3225B	Black reduction nipple, M32 => M25	EVH16...: included 1pc
RGM16B	Membrane gasket for cable Ø 5 - 9mm	
RMM25B	Membrane gasket for cable Ø 8 - 17mm	
RMM32B	Membrane gasket for cable Ø 12 - 24mm	

### 5.3. Wall mounting

- Make sure that the wall is robust and stable. The mounting surface must be flat and vertical.

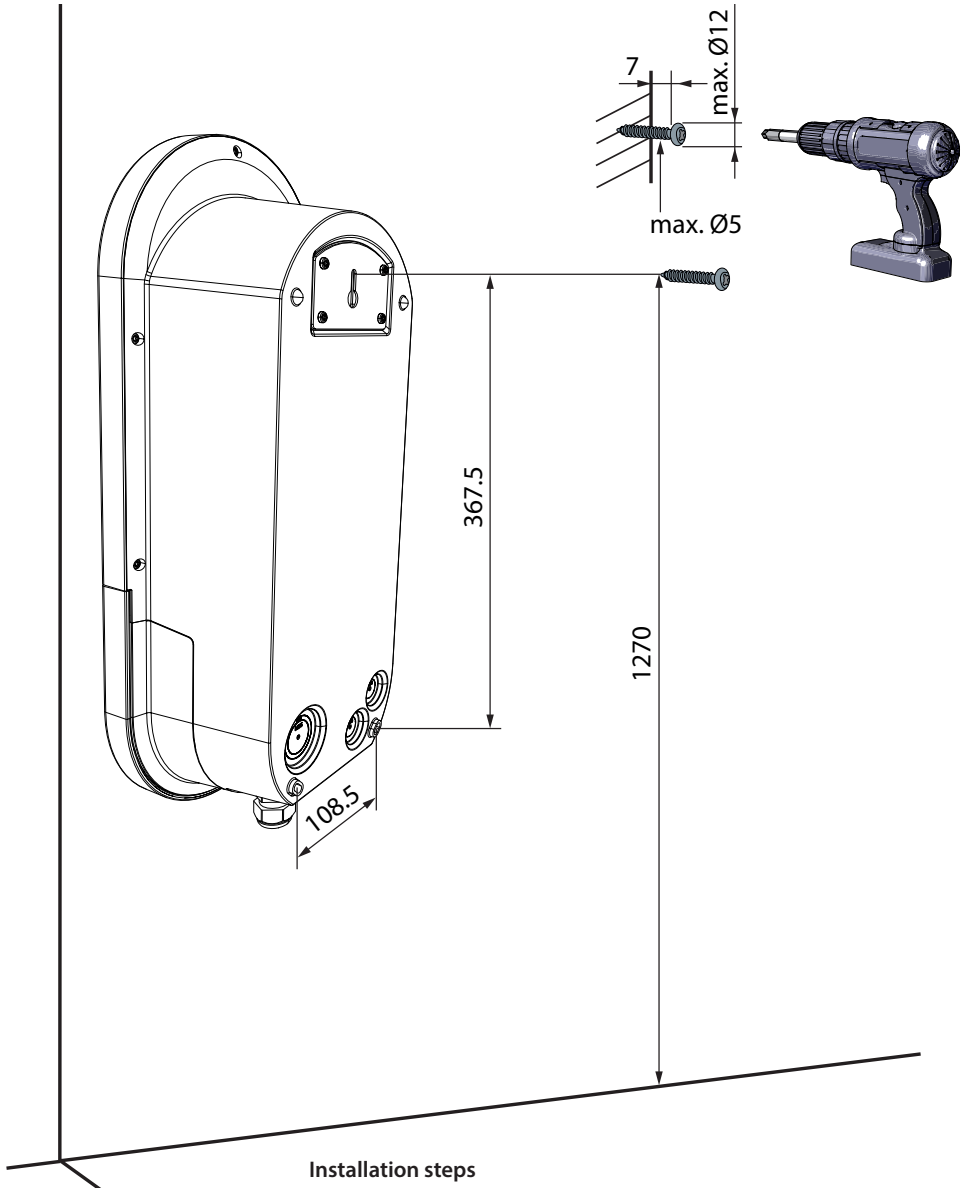

#### Installation steps

1. Select applicable screws for the the wall material.
2. Fasten the upper screw 1270 mm measured from the ground surface. The plug holder will be at a height of 1200 mm.

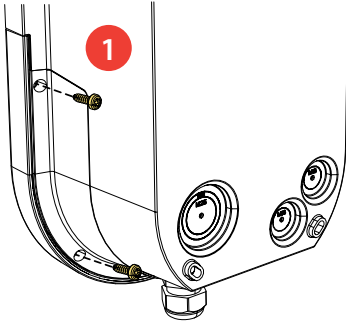

TX20  
Tightening torque 1,5 Nm

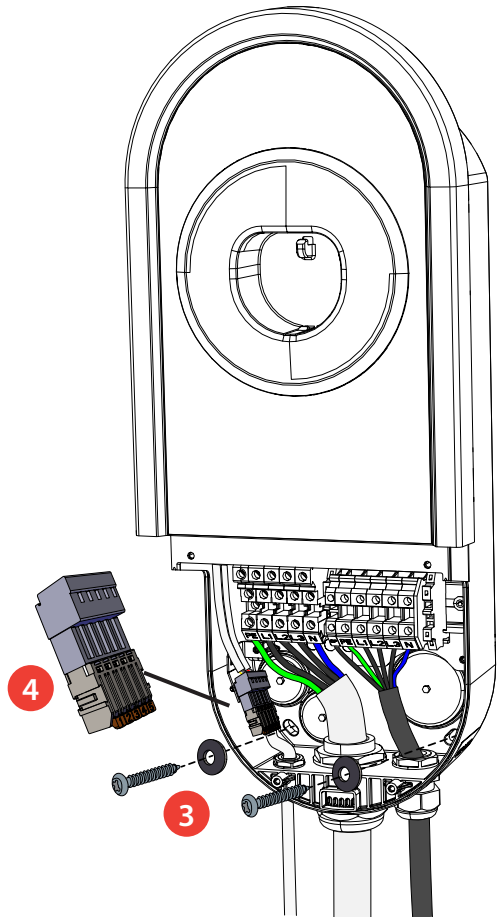
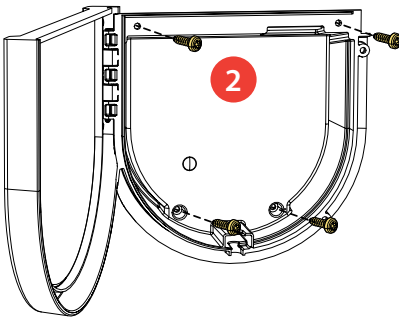

3. Open the installation box hatch by removing the fastening screws (2 pcs) / unlocking the hatch lock [1].
4. Remove the entire installation box cover by unscrewing the fastening screws (4 pcs) [2].
5. Hang the charging station on the screw you attached to the wall.
6. Attach the charging station on wall with two washers and fastening screws (not included) [3].  
**Be careful not to damage the fixed charging cable!**
7. Pull the electrical cables approx. 150mm through the cable glands.
8. Cut the supply cable conductors to applicable lengths. The earth conductor must be long enough, so that if a fault occurs it is the last one that comes loose.
9. Strip the conductors 11 mm and connect to the supply connectors.
10. Load management connections: If it is necessary to connect the charging station to an energy meter or an external control device, connect the required control cable to the pre-installed connector [4].
11. Put the installation box cover back in right position and fasten with the screws you removed.
12. Close the installation box hatch.

## 6. Electrical connections

The voltage and current ratings including cable sizes must comply with national regulations. The system dimensioning must be done by a qualified electrical designer.



*The default setting for the earthing system is TN network. If you connect the charging station to an IT network, you have to change the settings for the charging station accordingly.*

You can change the settings of the charging station with the **Charger Control Application**.

- Download the Charger Control application from Apple Store or Google Play.
- Pair your mobile device with the charging station.

For more information see the **User Guide** chapter **14. Charger Control Application**.

Settings intended for qualified professionals only, see the chapter **12. Charger Control Application**.

### 6.1. Power supply

#### **EVH161B-HC000 / EVH321B-HC000:**

- Install a residual current device (RCD type A, 30mA) and a circuit breaker (MCB max. 16A or max. 32A depending on charging station model) to the supply line. In addition obey local regulations for the power supply line.
- These charging station models can be connected to an IT network.

Note! The load management features do not support the IT network installation.

Please contact your local representative for more information.

#### TN network

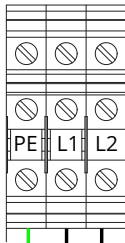

PE L N

Supply  
Cu 2.5 - 10 mm<sup>2</sup>

#### IT network

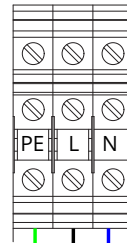

PE L1 L2

Supply  
Cu 2.5 - 10 mm<sup>2</sup>

**EVH163B-HC000 / EVH323B-HC000:**

- Install a residual current device (RCD type A, 30mA) and a circuit breaker (MCB max. 16A or max. 32A depending on charging station model) to the supply line. In addition obey local regulations for the power supply line.
- Do not connect these charging station models to an IT network.

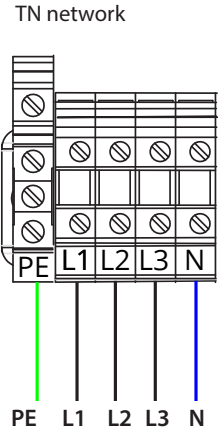

Supply  
Cu 2.5 - 10 mm<sup>2</sup>

**EVH161B-HCR00 / EVH321B-HCR00:**

- A combined device with residual current circuit breaker and over current protection (RCBO) is integrated.
- A label set of RCBO testing instructions is included in the delivery. Attach a language specific label on the installation box hatch.
- Do not connect these charging station models to an IT network.

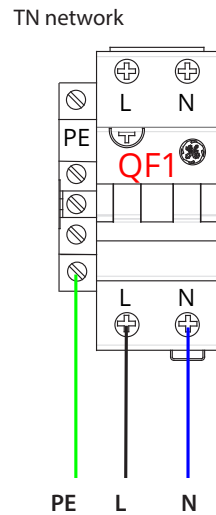

Supply  
Cu 2.5 - 10 mm<sup>2</sup>

### EVH163B-HCR00 / EVH323B-HCR00:

- A combined device with residual current circuit breaker and over current protection (RCBO) is integrated.
- A label set of RCBO testing instructions is included in the delivery. Attach a language specific label on the installation box hatch.
- Connect these charging station models to a 3-phase supply, otherwise the RCBO test button does not work.
- Do not connect these charging station models to an IT network.

TN network

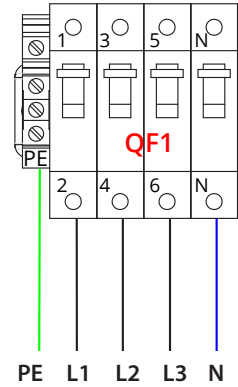

Supply  
Cu 2.5 - 10 mm<sup>2</sup>

## 6.2. Load management connections

Connect external control devices for load management to the pre-installed connector.

Note! Load management does not support IT earthing system.

If devices for load management functions are connected to the charging station, change the respective settings with the Charger Control Application.

### 6.2.1. Energy meter

- Use a twisted pair instrumentation cable RS-485 when you connect the energy meter to the charging station.
- Recommended cable type: NESMAK-HF 2x2x0,5+0,5 or similar.
- The system has been tested with 100 m cable length.
- Make sure that the signal wires are connected correctly to the energy meter.

## Legrand energy meters

- Connect the energy meter to terminals 1 [+], 2 [-] and 3 [SG]
- Make sure that the Modbus parameters of the charging station and energy meter are equal.
  - Modbus Address: 5
  - Baud rate: 19.200
  - Databits: 8
  - Parity: pair (even)
  - Stopbits: 1
- If necessary, configure the values in the Charger Control Application **“Settings/Charger settings/Property energy meter”** (in **PRO** mode settings see page 26) or in the energy meter settings. See the energy meter instructions for more detailed information.
- If there are communication problems on the RS-485 transmission line, such as echoes and reflections, terminate the line with an  $120\Omega$  resistor (not included). See the energy meter instructions for more information.

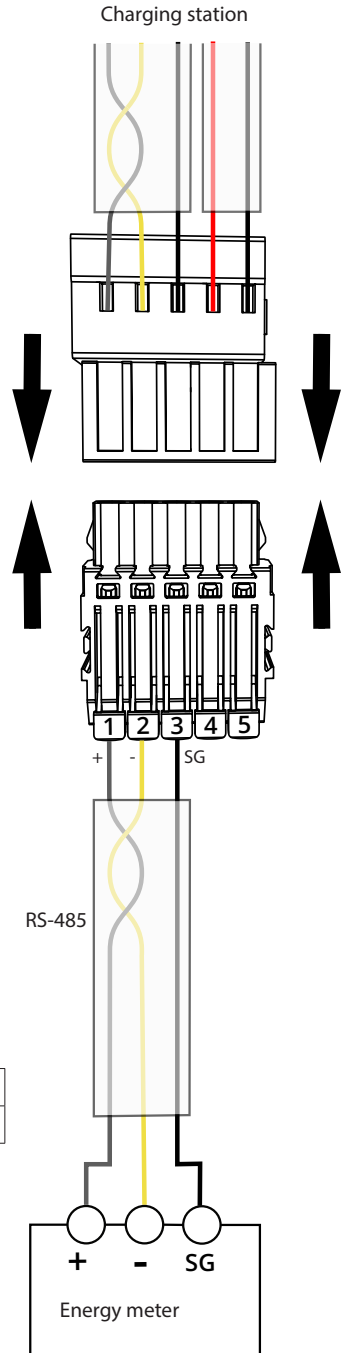

Legrand energy meters, e-catalogue part number					
4 120 81	4 120 83	4 120 91	4 120 93	4 120 41	4 120 43

## Alternative energy meter

- Connect the energy meter to terminals 1 [B+], 2 [A-] and 3 [GND].
- Make sure that the Modbus parameters of the charging station and energy meter are equal.
  - Modbus Address: client ID 1
  - Baud rate: 19.200
  - Databits: 8
  - Parity: none
  - Stopbits: 1
- If necessary, configure the values in the Charger Control Application **“Settings/Charger settings/Property energy meter”** (in **PRO** mode settings see page 26) or in the energy meter settings. See the energy meter instructions for more detailed information.
- Terminate the transmission line in accordance with the wiring example. Please see the energy meter instructions for more detailed information.

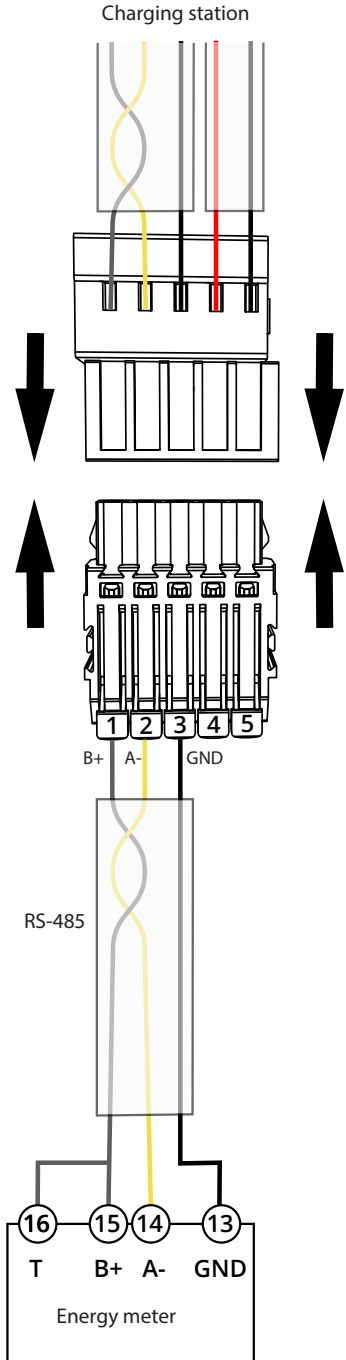





Vendor: Carlo Gavazzi	
Series	Part number example
EM21-72R	EM2172RVV23XOSX (Ensto EVHEM217)
EM330/EM340	EM340DINAV23XS1PFB
EM111/EM112	EM111DINAV81XS1PFB

### 6.2.2. External control device

- Connect a dry contact module for override mode to the terminals 4 and 5. Remove the jumper from the pre-installed connector.

**Note!** *If you do not connect a dry contact module to the charging station, do not remove the jumper or change the related settings in the Charger Control application.*

- Recommended cable type:  
Nestor HF, Dca - NESMAK-HF 2x2x0,5+0,5 K6/1000 or similar.
- The system has been tested with 200 m cable length.
- The default setting for external control is NC (normally closed).  
When the contact is closed, charging is allowed.  
When the contact is opened, charging is not allowed.
- If you install the external control as NO (normally open), change the settings accordingly in the Charger Control application.

External control	Switch	Charging
Normally closed (NC)		Allowed
		Not allowed
Normally open (NO)		Allowed
		Not allowed

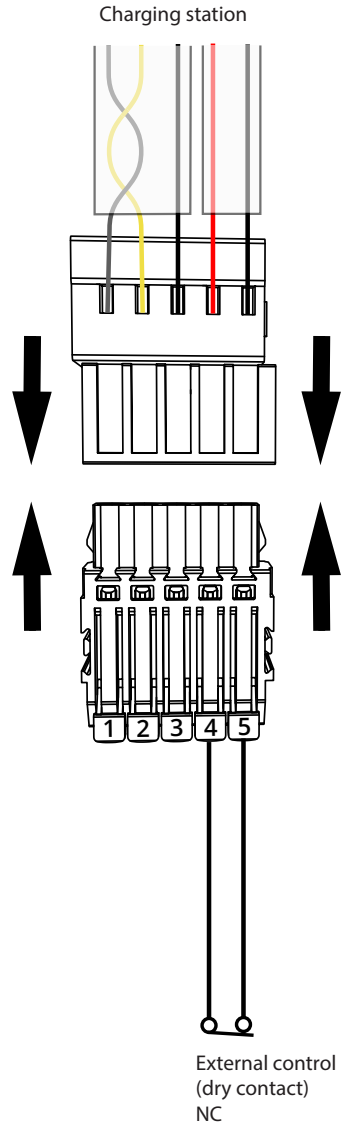

### 6.2.3. Dynamic Load Management (DLM)

You can implement dynamic load management with for this purpose compatible energy meter. The figure below shows an example how you can build up the system.

- The energy meter measures the total power consumption and the actual current per phase. If some other load over the set maximum current for load management is added when charging is ongoing, the charger will decrease the charging current. If the total power consumption reaches the allowed maximum power, the charging interrupts until the the total power consumption has decreased to a value at which the charging can continue.

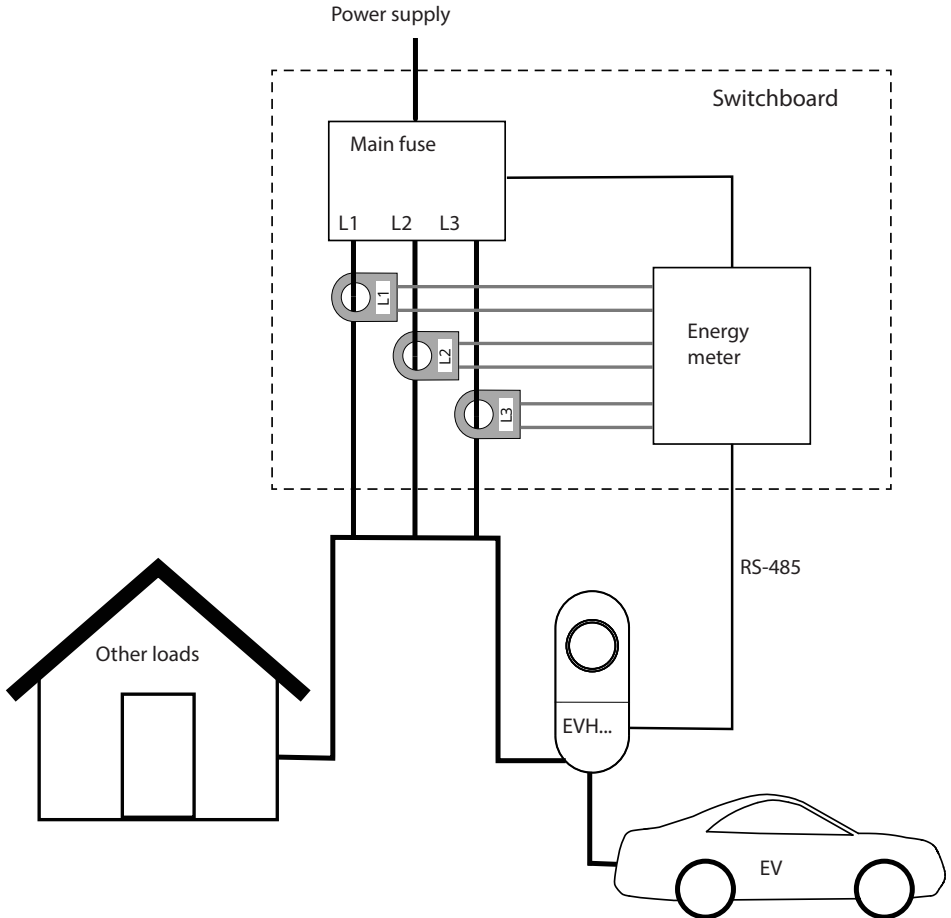

- Use only current transformers which have the same serial number, they are calibrated with one another.
- 1-phase measurement: select the correct parameters in the energy meter's settings.
- Please see the energy meter instructions for more detailed information.

## 6.2.4. Load Management in Override mode

Ensto One Home charging stations are compatible with a variety of home control systems.

The Legrand group has a wide assortment of devices for home control systems. The figure below shows an example how you can build up load management with Netatmo Connect.

- If the total load reaches the allowed maximum power, the Smart Load Shedder sends a signal to the Connected Contactor. The Connected Contactor switches off the charging current. When the Connected Contactor gets a signal that the total power consumption has decreased to a set value, it switches on the charging current.

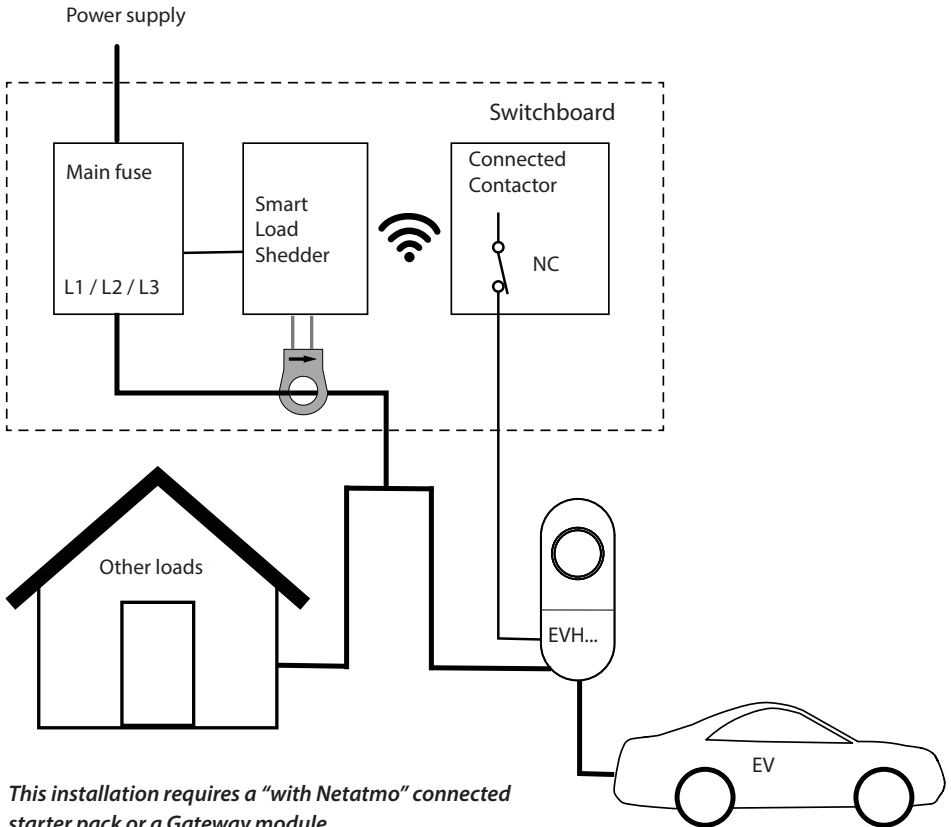

Device	Legrand catalogue part number
Smart Load Shedder	4 121 72
Connected Contactor	4 121 73

Please ask our local sales representative detailed information about the required devices for your installation.

### 6.2.5. Control of charging in Override mode

The charging events can be controlled by a dry contact module. The figure below shows an example how you can build up the override control of charging with a timer, switch, relay or similar.

When the dry contact is closed, the charging station gets power and can charge the connected vehicle. When the dry contact is open, the charging station does not get power and charging is not possible.

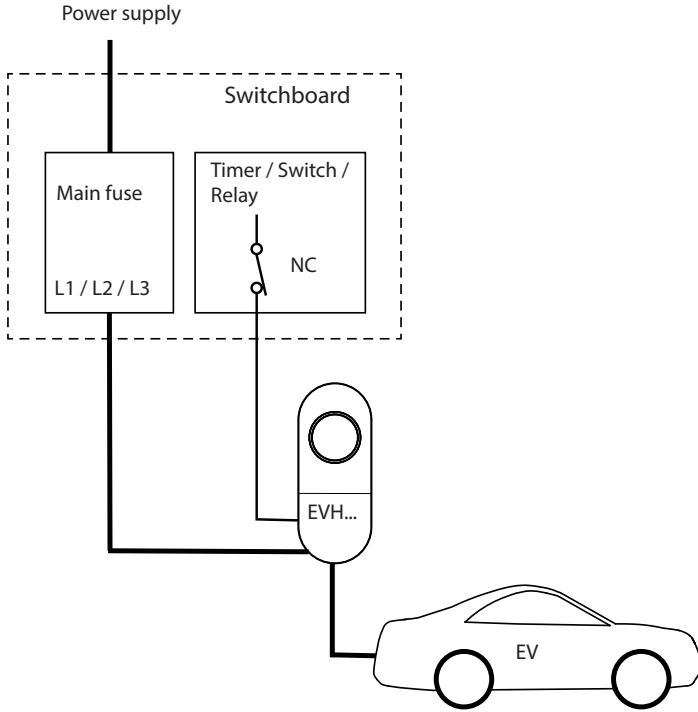

## 7. Technical information

Electrical Connections	EVH161B-HC000	EVH321B-HC000	EVH161B-HCR00	EVH321B-HCR00
Nominal supply voltage *	1-ph, 230 VAC			
Nominal frequency	AC 50 Hz			
Charging current max.	1x16 A	1x32 A	1x16 A	1x32 A
Charging power max.	3600 W	7400 W	3600 W	7400 W
Idle power loss	Depends on the LED settings: LED 1% => 1,5W / LED 50% => 1,8W / 100% => 3,9W			
Supply connections and terminals	L1, N, PE Cu 2.5 – 10 mm <sup>2</sup> Tightening torque: 1.5 - 1.8 Nm		L1, N, PE Cu 2.5 – 10 mm <sup>2</sup> Tightening torque PE: 1.5 - 1.8 Nm L + N: 2.5 - 3.0 Nm	

\* Supply voltage range 208 ... 264 V.

Please note that typically electric vehicles do not tolerate more than 7 volts of fluctuation in the main voltage during the charging session.

Electrical Connections	EVH163B-HC000	EVH323B-HC000	EVH163B-HCR00	EVH323B-HCR00
Nominal supply voltage *	3-ph, 400 VAC			
Nominal frequency	AC 50 Hz			
Charging current max.	3x16 A	3x32 A	3x16 A	3x32 A
Charging power max.	11 000 W	22 000 W	11 000 W	22 000 W
Idle power loss	Depends on the LED settings: LED 1% => 1,5W / LED 50% => 1,8W / 100% => 3,9W			
Supply connections and terminals	L1, L2, L3, N, PE Cu 2.5 – 10 mm <sup>2</sup> Tightening torque: 1.5 - 1.8 Nm		L1, L2, L3, N, PE Cu 2.5 – 10 mm <sup>2</sup> Tightening torque PE: 1.5 - 1.8 Nm L + N: 2.5 - 3.0 Nm	

\* Supply voltage range 360 ... 460 V.

Please note that typically electric vehicles do not tolerate more than 7 volts of fluctuation in the main voltage during the charging session.

Design and Mechanics	EVH161B-HC000 EVH163B-HC000	EVH321B-HC000 EVH323B-HC000	EVH161B-HCR00 EVH163B-HCR00	EVH321B-HCR00 EVH323B-HCR00
Material	Polycarbonate			
Color	Frame: RAL7021 dark grey Cover: Silver			
Installation box	Screw fixing		Mechanical hatch lock	
Weight	approx. 7 kg			
Ingress Protection	IP54			
Impact Resistance	IK10			
Operating temperature	-40 °C ... +50 °C			
Environmental service conditions	Indoor and outdoor use			
EV supply equipment classification	Equipment for locations with restricted access			
Mechanical resistance for stationary assembly	Medium resistance			
Mounting	Wall / Ground			

User Interface	EVH161B-HC000 EVH163B-HC000	EVH321B-HC000 EVH323B-HC000	EVH161B-HCR00 EVH163B-HCR00	EVH321B-HCR00 EVH323B-HCR00
Connection to vehicle	Fixed cable, length 5m <ul style="list-style-type: none"> <li>The use of adapters or conversion adapters to connect a charging cable to the charging outlet is not allowed.</li> <li>The use of cord extension sets to extend the charging cable range is not allowed.</li> </ul>			
Charging status indication	4-color LED: Green = Ready / Blue = Charging / Red = Error / Yellow = Internal maintenance			
Use access	Free access or authorization mode Settings done via mobile application			

Safety Features	EVH161B-HC000 EVH163B-HC000	EVH321B-HC000 EVH323B-HC000	EVH161B-HCR00 EVH163B-HCR00	EVH321B-HCR00 EVH323B-HCR00
Residual current device RCD	Leakage detection integrated RDC-DD, 6mA RCD, type A 30mA must be installed in distribution board		Leakage detection integrated RDC-DD, 6mA Residual current circuit breaker and over current protection integrated, RCBO, 30mA	
Miniature circuit breaker MCB	Max. 16A must be installed in distri- bution board	Max. 32A must be installed in distri- bution board		

Control and Communication	EVH161B-HC000 EVH163B-HC000	EVH321B-HC000 EVH323B-HC000	EVH161B-HCR00 EVH163B-HCR00	EVH321B-HCR00 EVH323B-HCR00
Operation mode	Standalone			
Wireless	Bluetooth			
Load management	Dynamic Load Management			
	<ul style="list-style-type: none"> <li>Supported energy meters (not included), see pages 13 and 14</li> </ul>			
Charging control system	Override			
	<ul style="list-style-type: none"> <li>required external control devices are not included</li> </ul>			
Charging control system	“Simplified control pilot” functionality, specified in EN IEC 61851-1:2019, Annex A.2.3 is not supported. ZEReady 1.2b and EVReady 1.4b are not supported.			

## 8. Code key

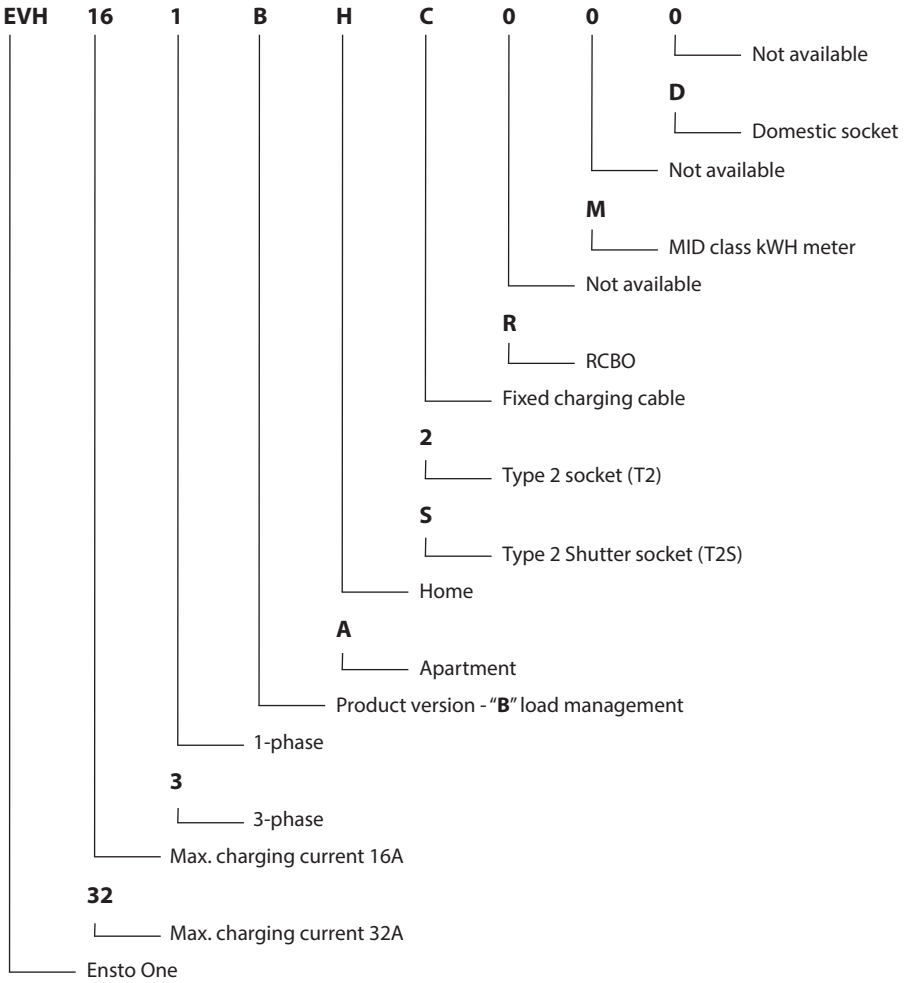

## 9. Installation / Commissioning checklist

### Introduction

Examine the mechanical and electrical installation in accordance with this checklist to make sure that the charging station is properly installed.

### Checking the Installation



*Examine the visual, mechanical and electrical installation when the charging station is un-powered.*

CATEGORY	X	ITEM
Overall look		You have received the ordered material.
		You do not see any scratches or damages.
Mechanical installation		The charging station is fixed properly on the installation site.
Electrical installation		Charging station's power supply capacity meets the electrical planning (cable size, protective devices...). Review the local electrical design plan.
		The PE-cable screw is tight.
		The power supply conductors (L1, L2, L3, N and PE) are properly connected.
		The insulation of the power supply cable and conductors (L1, L2, L3, N and PE) is intact.
		TN network: <ul style="list-style-type: none"> <li>The voltage between PE and N is less than 10 V.</li> </ul> IT network: <ul style="list-style-type: none"> <li>The voltage between L1 and N is 230 V.</li> <li>The voltage between L1 and PE is 130 V.</li> </ul>
		The PE conductor resistance is less than 3 Ω.
Operational check		All the LED states / color (green, blue, red) are functioning. <ul style="list-style-type: none"> <li>Use a car simulator.</li> <li>Create fail and charge.</li> <li>Red at bootup, green at idle and blue while charging.</li> </ul>
		Test the functionality of load management, if in use.
		Test the functionality of the protective device.
Ready for use		Update the software with the Charger Control application, if a new version is provided. <b>Obey the instructions given by the Charger Control application during the update.</b>

## 10. Dimension drawing

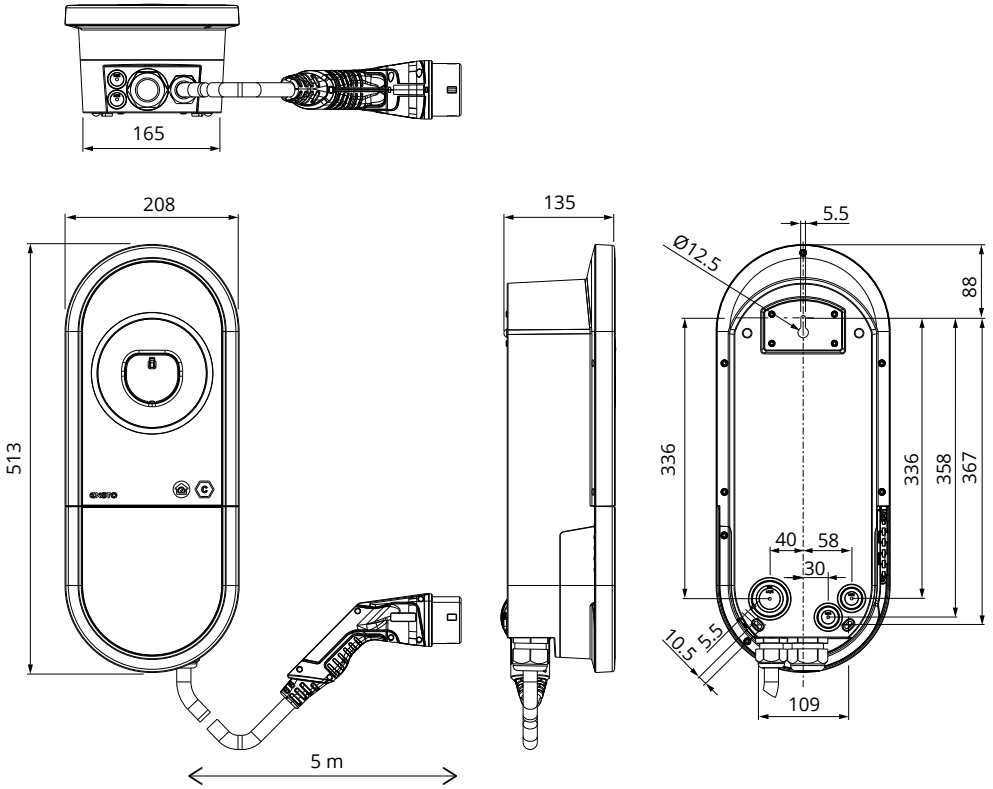

## 11. Troubleshooting

### *Charging station is off, no lights on*

<b>Issue</b>	<b>Corrective action</b>
Mains voltage does not exist in supply connectors (L1, L2, L3).	Make sure that the supply conductors are properly connected. Make sure that there is power available.
The circuit breaker QF1 is off (EVH...-HCR00).	Turn the QF1 on.

## 12. Charger Control Application

- The charging station is ready to use after the installation is completed.
- You can control the charging station and change settings with the Charger Control Application.
- In this chapter is described the settings, which are only allowed for qualified professionals.
- For additional instructions please see the User Guide for the Ensto One Home charging station.

**Note! Do not change the settings while charging is in progress.**

### 12.1. Pro settings in the Charger Control Application



#### WARNING

**Danger of electric shock! Risk of fire!**

- **Settings described in this chapter must only be done by a qualified professional.**

#### Enter / Exit the Pro mode

- Open the Charger Control on your mobile device.
- Go to «**Settings**».
- Select the three dots on the top right corner and press **Enter PRO mode / Exit PRO mode**.
- Available settings depend on the installed charging system.

### 12.2. Charger Settings

In this menu you can find settings related to the charging station.

#### 12.2.1. Technical max. charging current

- Maximum current that the electrical supply of the property can provide to the charging station.
- When you define the technical maximum current, take into account the main fuse size and the possible total energy consumption of the property. A safety limit prevents unnecessary triggering of the fuse and protective devices.

#### 12.2.2. Overcurrent limit

- Certain car models tend to take more charging current than set as the charging station's maximum charging current.
- In case an overcurrent of 10% lasts longer than 2 minutes, it results an error state. If the overcurrent is 16% it results an error state immediately.
- You can prevent unnecessary error states by setting an overcurrent limit.
- If the charging current is lower than 10A, you can set the overcurrent limit up to 30%.

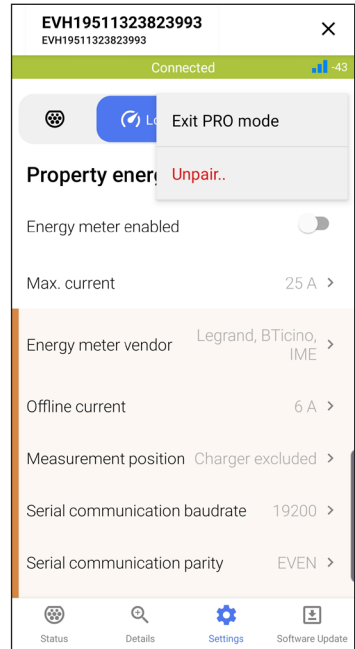

### 12.2.3. Earthing System

The default setting for power supply is TN network. If you connect the charging station to an IT network, you have to change settings for the charging station accordingly.

### 12.2.4. Connected phases

Select the phase the charging station is connected to.

### 12.2.5. Phase rotation (only 3-phase chargers)

Selection of phase rotation is only informative and does not affect the charging station's operation.

### 12.2.6. Start Self test

- The charging station performs a self test automatically at start-up.
- During the self-test, several components and their proper function is tested.
- The LED indicator is stable green during the self test.
- The extent and duration of the self test depend on the charging station model.
- If a critical fault is detected during the self test, the charging station will go to error state. You can see the error code in the error log.

### 12.2.7. Factory Reset

Here you can restore the charging station's factory settings.

## 12.3. Load Management Settings

In this menu you can find settings which are related to load management.

### 12.3.1. Energy meter vendor

Select the installed energy meter.

### 12.3.2. Offline current

The maximum charging current, if the connection to the Dynamic Load Management (DLM) server is interrupted.

### 12.3.3. Measurement position

The charging station can be included to or excluded from the energy measurement.

### 12.3.4. Connectivity settings

In these submenus you can modify the connectivity settings.

### 12.3.5. External control (dry contact)

Here you can change the settings for the override mode. The default setting for the contact is normally closed (NC).

- Charging is allowed when the contacts are closed.
- Charging is not allowed when the contacts are opened.

Legrand Finland Oy  
Linnoitustie 11,  
02600 Espoo, Finland  
Tel: +358 20 486 5010  
[www.legrand.fi](http://www.legrand.fi)

