

ENSTO

Ensto Pro EVF200 / EVF300



EN Installation Instructions
User Guide

CE

RAK112B_EN
2026-02-24
© 2024 Legrand Finland Oy

Contents

Installation Instructions

1. Safety instructions.....	3
2. Description of symbols.....	3
3. Abbreviations.....	4
4. Delivery contents.....	4
5. Accessories - installation method and site.....	5
6. Accessories - order numbers and dimensions.....	6
7. Mounting instructions.....	10
7.1. Before installation.....	10
7.2. EVF200 mounting on concrete casting at site.....	11
7.3. EVF200 mounting on ground mounting frame.....	13
7.4. EVF200 mounting on concrete foundation.....	14
7.5. EVF200 mounting on Unimi concrete foundation.....	16
7.6. EVF300 mounting on concrete casting at site.....	18
7.7. EVF300 mounting on concrete foundation.....	21
8. Supply connections.....	23
9. Commissioning.....	26
9.1. External connection terminals.....	26
9.2. View of the component layout on the control unit.....	27
9.3. Connecting to the charging station.....	28
9.4. Ethernet connections.....	29
9.5. WiFi coverage area.....	29
10. Technical data.....	31
12. Installation / Commissioning checklist.....	34
11. Cybersecurity.....	35
11.1 Cyberseccrity actions.....	35
11.2 Unique access passwords.....	35
11.2.1 INSTALLER password.....	35
11.2.2 OPERATOR password.....	35
12. Dimensional drawings.....	36
13. Maintenance / Preventive maintenance instructions.....	38
14. Testing instructions for the electric protective device.....	39
15. Troubleshooting.....	39
16. Code key.....	40
17. Warranty.....	40
18. Declaration of Conformity.....	40
19. Disposal.....	40

User Guide

20. User interfaces.....	41
21. Charging.....	41
21.1. Free charging.....	41
21.2. Charging with RFID.....	42

Installation Instructions

1. Safety instructions



Electrically skilled person

- The installation must only be done by a qualified professional.
- Read these instructions carefully before you install, operate or maintenance the charging station.
- Obey the instructions in this manual and make sure that the installation complies with national safety regulations, installation methods and restrictions.
- The information provided in this manual in no way exempts the installer or user from responsibility to obey all applicable safety regulations.
- Keep this manual for future reference.



WARNING

Danger of electric shock! Risk of fire!

- *Improper installation can cause personal injury and property damage.*
- *Do not switch on the power supply before the installation work is completed.*

2. Description of symbols

	WARNING - Indicates a hazard with a medium level of risk which, if not avoided, could result in death or serious injury or considerable damage to the equipment.
	Electrically skilled person is a person with relevant education and experience to enable him or her to perceive risks and to avoid hazards that electricity can create.
	Identifier for plug and socket outlet AC / EN62196-2 / Type 2
	Radio-frequency identification reading area for automatical identifying of RFID tags.
	Environmental instructions

3. Abbreviations

Abbreviation	Description
LED	Light Emitting Diode
MCB	Miniature Circuit Breaker, protects cables and equipment from over load and short circuits
OCPP	Open Charge Point Protocol, protocol how the charger communicates with the backend systems
RCBO	Residual current Circuit Breaker with Overcurrent protection
RCD	Residual Current Device, protects humans and animals from electric shock
RDC-DD	Residual direct current detecting device, protects humans and animals from electric shock
RFID	Radio Frequency Identification, information remote reading/writing system, here used to identify authorized charging point users
USB	Universal Serial Bus, specifications for cables, connectors and protocols
RS-485	Recommended Standard 485, standard defining the characteristics of drivers and receivers for use in serial communications systems

4. Delivery contents

- Charging station
- Triangular key
- Installation Instructions / User Guide in English, other languages please see www.legrand.com

Ensto Pro (EVF) is a solution for charging two electric vehicles.

The charging station is engineered especially for fast AC charging (max. 22kW).

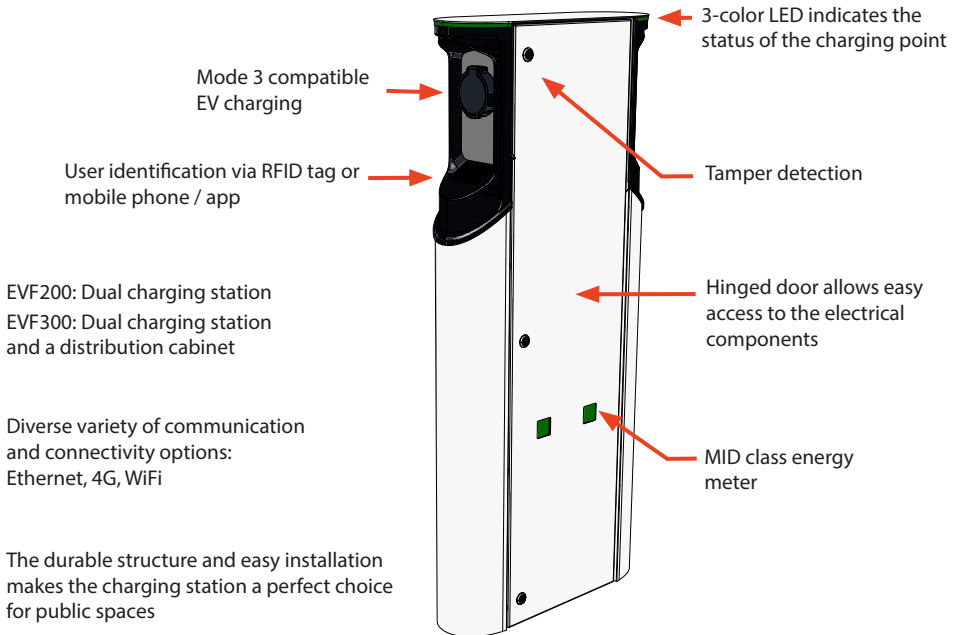

5. Accessories - installation method and site

The delivery does not include any installation accessories.

Please order applicable accessories for the selected mounting method separately.

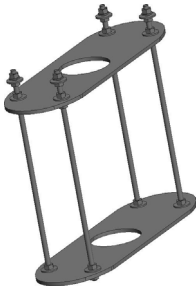
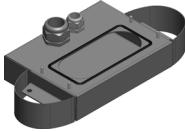
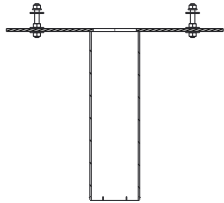
EVF200		
Installation method and site	Accessories	
Ground mounting on concrete at site	 <p>EVTL32.00: Ground mounting box, cable entry from bottom *</p>	Anchor bolts from a local supplier
Ground mounting on ground mounting frame	<p>or</p>	 <p>EVTL28.00: Ground mounting frame</p>
Ground mounting on concrete foundation	 <p>EVTL36.00: Adapter</p>	 <p>Concrete foundation, product code SJR-08 from Sähkö-Jokinen Oy, https://www.sahkojokinen.fi/en</p>
Ground mounting on Unimi concrete foundation	<p>EVTL34.00: Ground mounting box, cable entry from top *</p>	<p>From Unimi Solutions: Concrete foundation, product code 100-1 Cover plate Adapter, product code 100-13 www.unimi.se</p>

* EVTL32.00 or EVTL34.00 is mandatory to get the IP54 classification of the charging station.

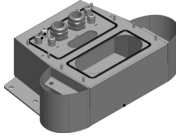
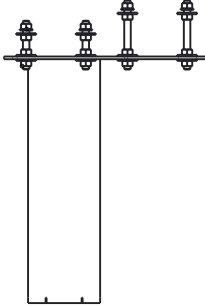
EVF300	
Installation method and site	Accessories
Ground mounting on concrete at site	Anchor bolts from a local supplier
Ground mounting on concrete foundation	 <p>EVTL35.00: Ground mounting box *</p>
	 <p>EVTL37.00: Adapter</p>
	<p>Concrete foundation, product code SJR-08 from Sähkö-Jokinen Oy, https://www.sahkojokinen.fi/en</p>

* EVTL35.00 is mandatory to get the IP54 classification of the charging station.

6. Accessories - order numbers and dimensions

EVTL32.00 ground mounting box for EVF200

EVTL32.00 is a ground mounting box with cable entry from bottom.

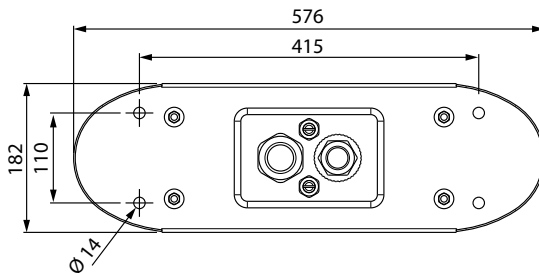
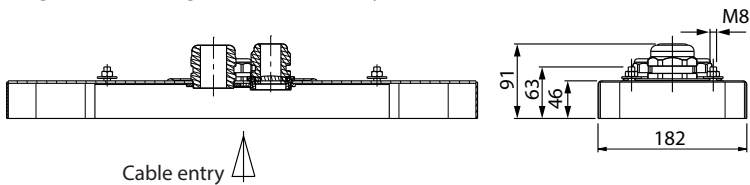

Cable glands M40x1.5: cable \varnothing 18-25mm
Optional M50: cable \varnothing 22-32mm



EVTL34.00 ground mounting box for EVF200

EVTL34.00 is a ground mounting box with cable entry from top.

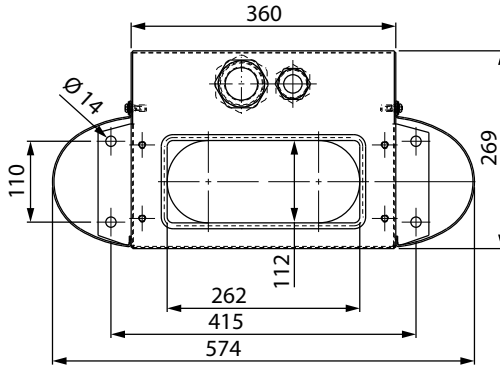
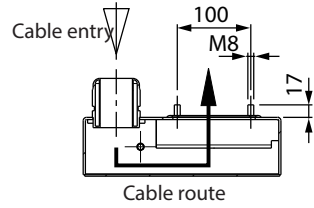
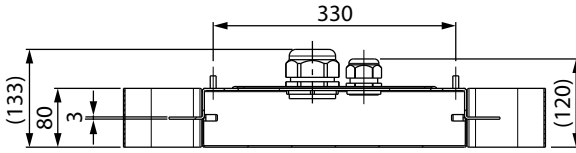

Cable glands M40x1.5: cable \varnothing 18-25mm
Optional M50: cable \varnothing 22-32mm

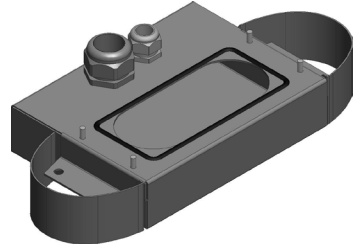

EVTL28.00 Ground mounting frame for EVF200

EVTL28.00 is a whole set as shown on the picture.

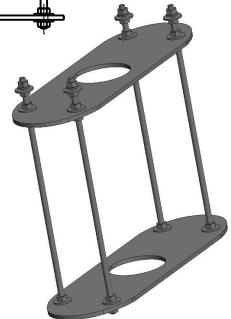
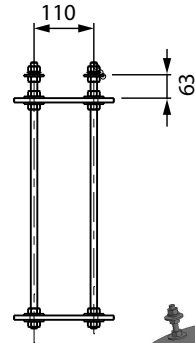
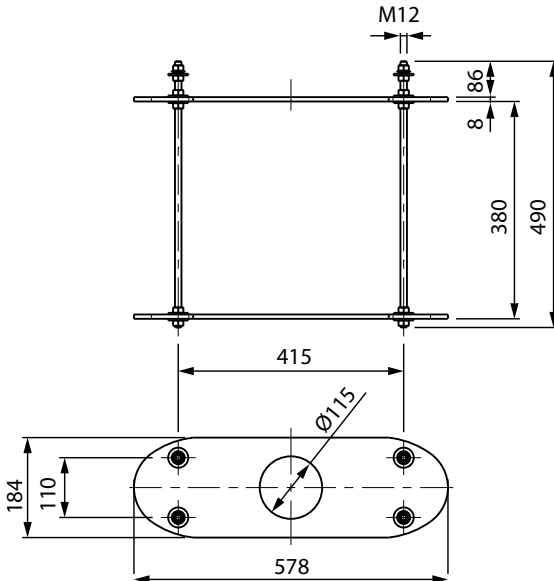

EVTL36.00 concrete foundation adapter for EVF200

The concrete foundation adapter is designed to be used with a concrete foundation, product code SJR-08, supplied by Sähkö-Jokinen Oy. Please order the foundation from: <https://www.sahkojokinen.fi/en>

If you want to use a foundation from another manufacturer, make sure that the foundation is compatible with the adapter.

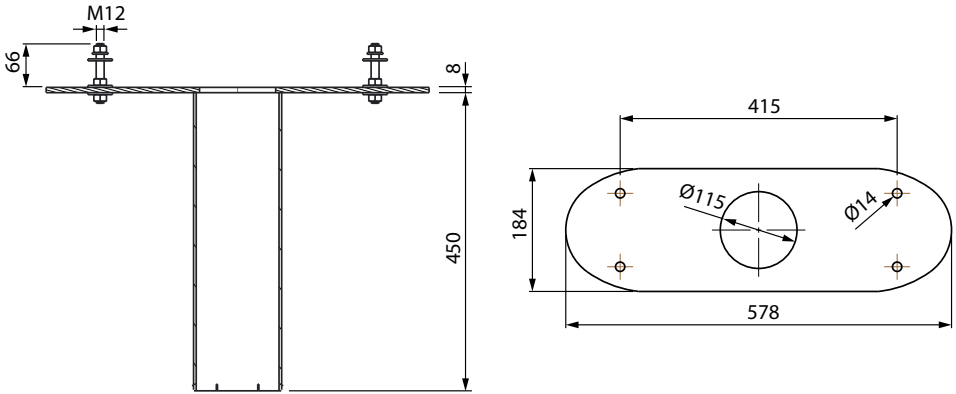

EVTL35.00 mounting box for EVF300

EVTL35.00 is a ground mounting box with cable entry from bottom to the main board.

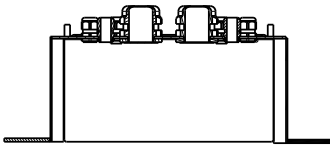
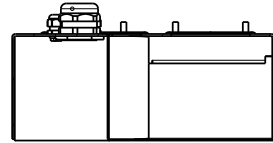
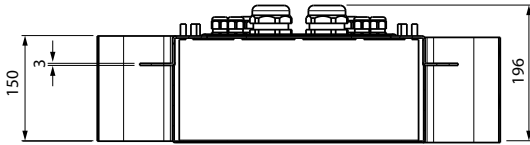

Cable glands M40x1.5: cable \varnothing 18-25mm
Optional M50: cable \varnothing 22-32mm

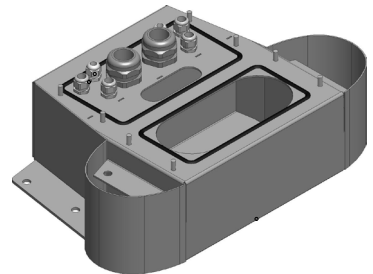
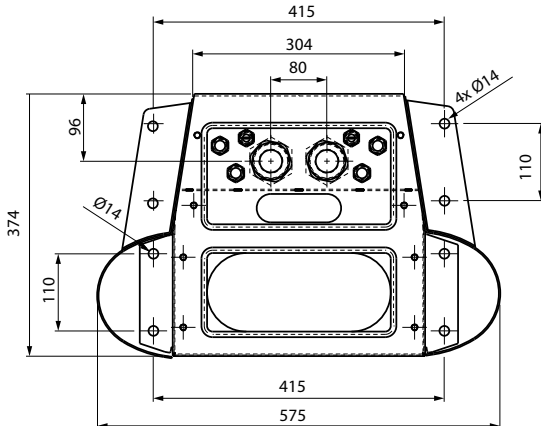

EVTL37.00 concrete foundation adapter for EVF300

The concrete foundation adapter is designed to be used with Sähkö-Jokinen SJR-08 foundation.
Please order the foundation from: <https://www.sahkojokinen.fi/en>

If you want to use a foundation from another manufacturer, make sure that the foundation is compatible with the adapter.

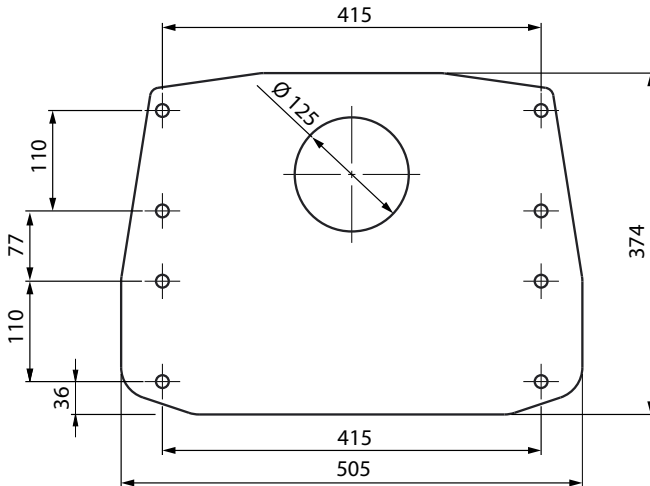
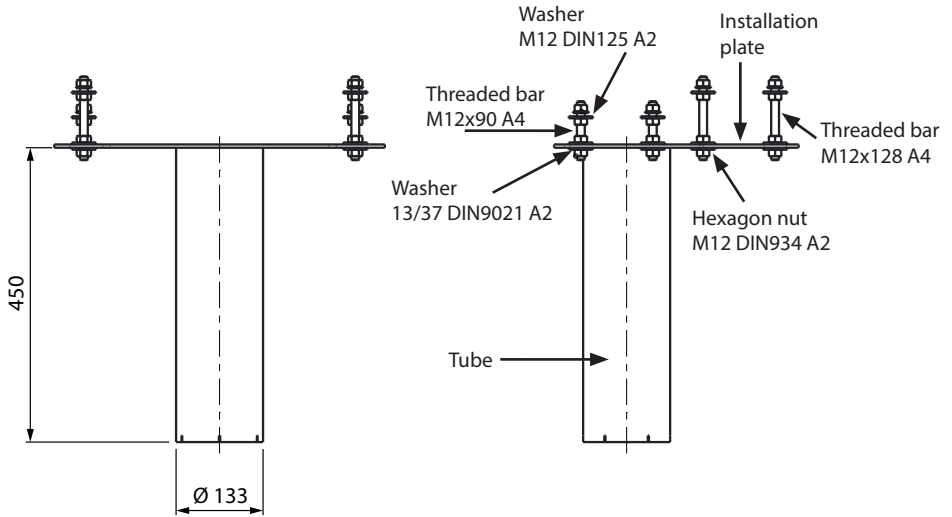

7. Mounting instructions

7.1. Before installation

Remove the package around the charging station. Remove the film protecting the metal parts only after the installation is completed.

Note! When you select the installation location, take into consideration the minimum space necessary for operating and maintenance.

EVF200

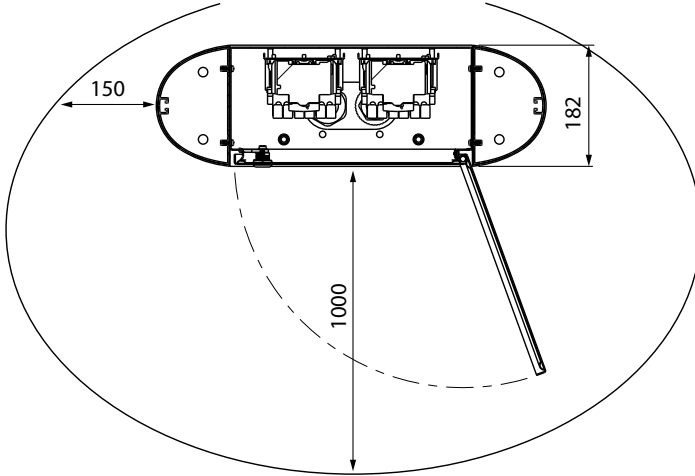

EVF300

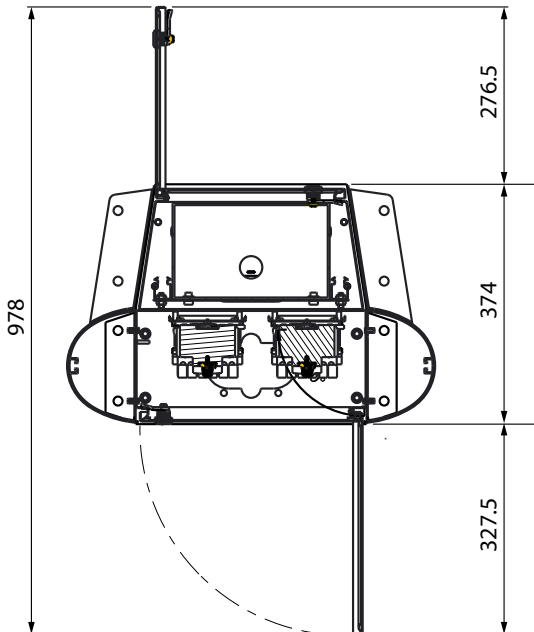

7.2. EVF200 mounting on concrete casting at site

Installation accessories	Ground mounting box EVTL32.00 / EVTL34.00	1 pc
	Anchor bolts M12	4 pcs
	Washers	
	Nuts	

Make sure that the materials used for the concrete foundation and the installation procedures follow local building regulations and safety standards.

- Dig a trench for cable conduits and an excavation pit for the concrete foundation. The pit floor should be compacted and level.
- Put cable and possible drain pipes in place.
- Fill the pit with concrete.
- Let the concrete cure, make sure that the surface stays level during the process.

Installation steps

1. Drill a hole in the concrete for the anchor bolts. For more information see the anchor bolt instructions. Use the ground mounting box as a jig.

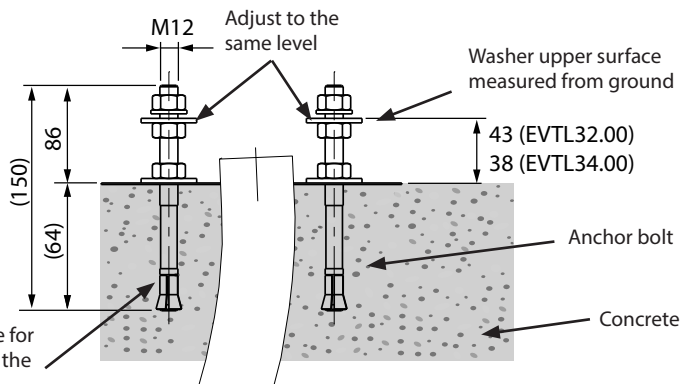
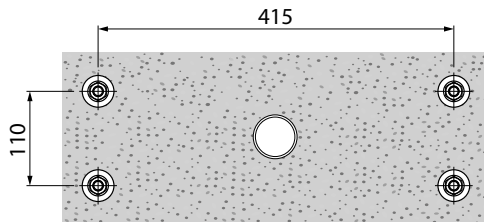
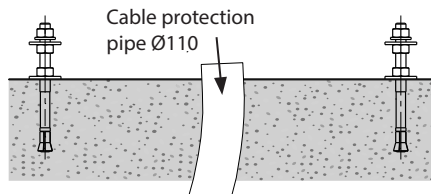

Select anchor bolts applicable for the thickness and strength of the concrete

2. Put the anchor bolts in place and tighten the anchor bolt nuts.
3. Adjust the upper nuts and washers on the anchor bolts horizontally. Use a spirit level.
4. Attach the mounting box to the anchor bolts with applicable washers and nuts.

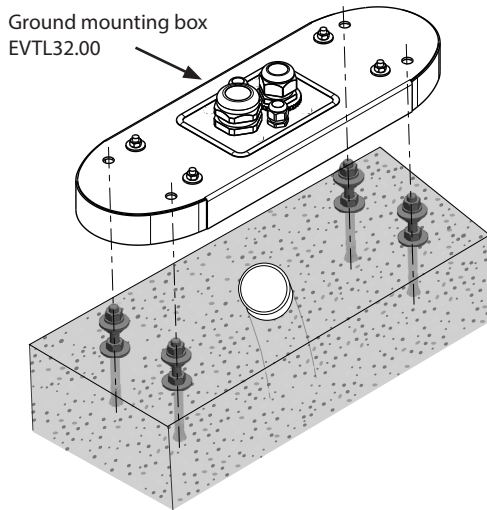

5. **EVTL32.00:** Pull electrical cables through the ground mounting box cable gland(s) approx. 400 mm measured from the upper surface of the mounting box.
EVTL34.00: Pull electrical cables through the ground mounting box cable gland(s) and further through the mounting box cable hole approx. 400 mm measured from the upper surface of the mounting box.
6. Tighten the cable gland(s). Close the unused cable entries with cable gland plugs.
7. Open the maintenance door of the charging station.
8. Remove the nuts and the washers from the ground mounting box.
9. Lift the charging station on the ground mounting box. Pull the electrical cables through the cable hole.
10. Attach the charging station in place with the washers and the nuts you removed from the ground mounting box.
11. **EVTL32.00:** Remove the supply cable sheath at the length of max. 200 mm.
EVTL34.00: Remove the supply cable sheath beginning from the cable gland exit.
12. Cut the supply cable conductors to applicable lengths. The earth conductor must be long enough, so that if a fault occurs it is the last one that comes loose.
13. Strip the supply cable conductors 25 mm.
14. Connect the supply cable conductors to the supply terminal blocks.
15. Make sure that the PE is connected to the charging station.
16. Make sure that there are not any loose connections (connectors or conductors) in the charging station.
17. Switch on F0, F1, F2 (if present) and QF1.
18. Close the maintenance door.

7.3. EVF200 mounting on ground mounting frame

Installation accessories	Ground mounting frame EVTL28.00	1 pc
	Ground mounting box EVTL32.00 / EVTL34.00	1 pc

Make sure that the materials used for the concrete foundation and the installation procedures follow local building regulations and safety standards.

- Plan the installation depth so that the top surface of the ground mounting frame is flush with the final ground surface. Take into consideration the possible paving materials.
- Dig a trench for cable conduits and an excavation pit (depth approximately 490 mm) for the concrete foundation. The pit floor should be compacted and level.
- Put the ground mounting frame into the pit.
- Put cable and possible drain pipes in place.
- Pour concrete over the frame and pipes.
- Let the concrete cure. Make sure that the surface stays level during the process.

Installation steps

1. Remove the upper nuts and washers from the top of the ground mounting frame bolts.
2. Put the mounting box on the mounting frame.
3. Adjust the nuts on the mounting frame bolts so that the top surface of the mounting box is horizontal.
4. **EVTL32.00:** Pull electrical cables through the ground mounting box cable gland(s) approx. 400 mm measured from the upper end of the mounting box.
EVTL34.00: Pull electrical cables through the ground mounting box cable gland(s) and further through the mounting box cable hole approx. 400 mm measured from the upper end of the mounting box.
5. Tighten the cable gland. Close the unused cable entries with cable gland plugs.
6. Open the maintenance door of the charging station.
7. Remove the nuts and the washers from the ground mounting box.
8. Lift the charging station on the mounting box. Pull the electrical cables through the cable hole.
9. Attach the charging station in place with the washers and the nuts you removed from the ground mounting box.
10. **EVTL32.00:** Remove the supply cable sheath at the length of max. 200 mm.
EVTL34.00: Remove the supply cable sheath beginning from the cable gland exit.
11. Cut the supply cable conductors to applicable lengths. The earth conductor must be long enough, so that if a fault occurs it is the last one that comes loose.
12. Strip the supply cable conductors 25 mm.
13. Connect the supply cable conductors to the supply terminal blocks.
14. Make sure that the PE is connected to the charging station.
15. Make sure that there are not any loose connections (connectors or conductors) in the charging station.
16. Switch on F0, F1, F2 (if present) and QF1.
17. Close the maintenance door.

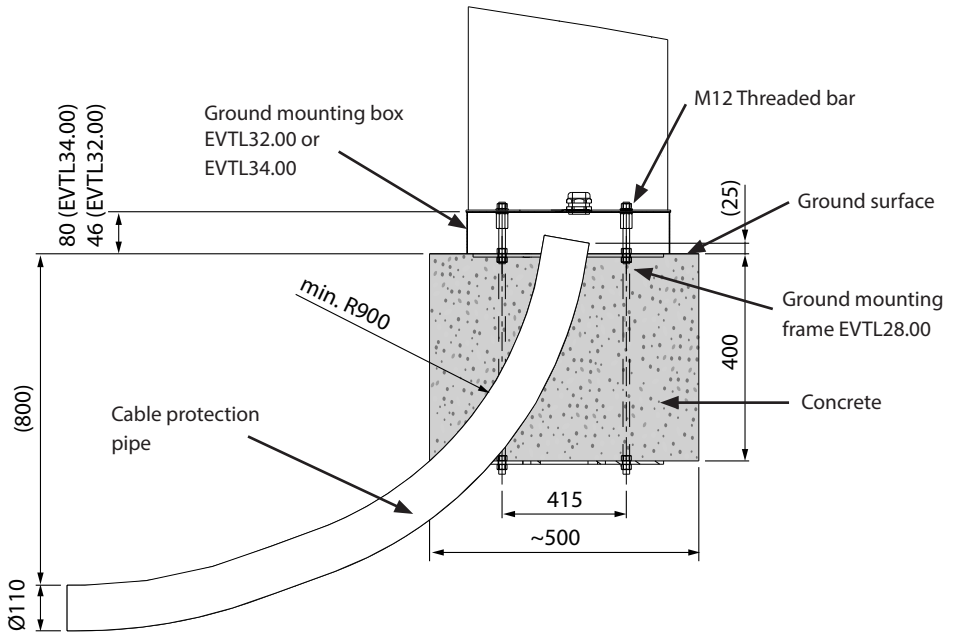

7.4. EVF200 mounting on concrete foundation

Installation accessories	Ground mounting box EVTL32.00 / EVTL34.00	1 pc
	Adapter for concrete foundation EVTL36.00	1 pc
	Concrete foundation	1 pc

This example describes the installation procedure when using a concrete foundation supplied by Sähkö-Jokinen Oy, product code SJR-08.

If you want to use a foundation manufactured by another supplier, make sure that the foundation is compatible with the adapter.

- Plan the installation depth so that the top surface of the adapter is above the ground surface. Take into consideration the possible paving materials.
- Dig a trench for cable conduits and an excavation pit for the concrete foundation to applicable depths.
- Lift the foundation into the pit.
- Put cable and possible drain pipes in place. Install the pipes in relevant inlets.
- Close the unused inlets with plugs.
- Tighten the foundation to its place by filling the excess space outside the foundation with gravel.

Installation steps

1. Assemble the concrete foundation adapter.
2. Attach the mounting box EVTL32.00 / EVTL34.00 on the concrete foundation adapter EVTL36.00 and put the assembly on the concrete foundation.
3. Attach the assembly in place. Use the screws on the concrete foundation.
4. **EVTL32.00:** Pull electrical cables through the ground mounting box cable gland(s) approx. 400 mm measured from the upper end of the mounting box.
EVTL34.00: Pull electrical cables through the ground mounting box cable gland(s) and further through the mounting box cable hole approx. 400 mm measured from the upper end of the mounting box.
5. Tighten the cable gland. Close the unused cable entries with cable gland plugs.
6. Open the maintenance door of the charging station.
7. Remove the nuts and the washers from the ground mounting box.
8. Lift the charging station on the mounting box. Pull electrical cables through the cable hole.
9. Attach the charging station in place with the washers and the nuts you removed from the ground mounting box.
10. **EVTL32.00:** Remove the supply cable sheath at the length of max. 200 mm.
EVTL34.00: Remove the supply cable sheath beginning from the cable gland exit.
11. Cut the supply cable conductors to applicable lengths. The earth conductor must be long enough, so that if a fault occurs it is the last one that comes loose.
12. Strip the supply cable conductors 25 mm.
13. Connect the supply cable conductors to the supply terminal blocks.
14. Make sure that the PE is connected to the charging station.
15. Make sure that there are not any loose connections (connectors or conductors) in the charging station.
16. Switch on F0, F1, F2 (if present) and QF1.
17. Close the maintenance door.

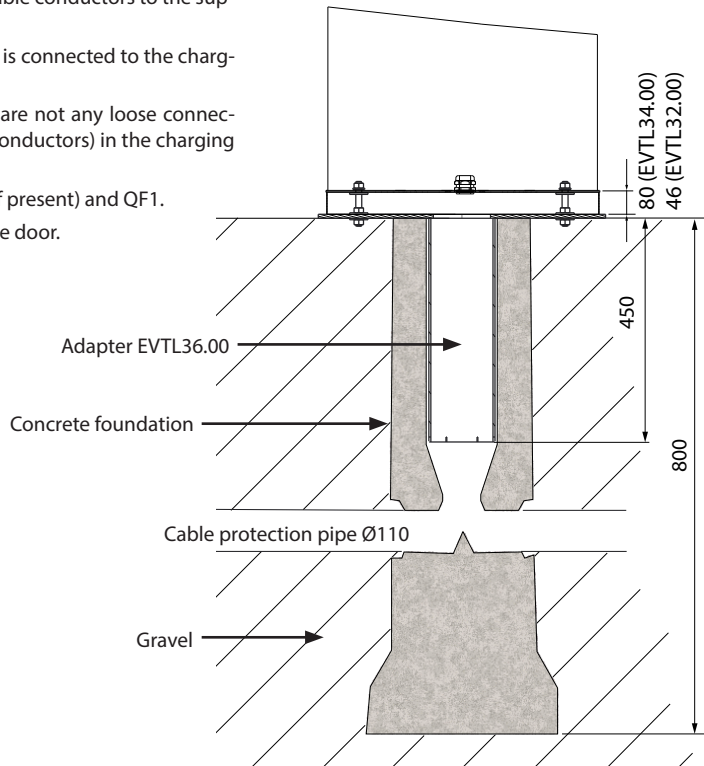

7.5. EVF200 mounting on Unimi concrete foundation

This example describes the installation procedure when a concrete foundation supplied by Unimi Solutions is used.

Installation accessories	Ground mounting box EVTL32.00 / EVTL34.00	1 pc
	Please order the following items from www.unimi.se	
	Concrete foundation Ensto Pro, product code 100-1	1 pc
	Cover plate	1 pc
	Ensto EVF compatible adapter element, product code 100-13	1 pc

Installation steps

Figure 1

- Dig a trench for cable conduits and an excavation pit for the concrete foundation to applicable depths. The pit floor should be compacted and level.
- Adjust the depth of the pit so that the top of the foundation will be flush with the final surrounding ground surface. Take into consideration the possible paving materials.
- Close the unused conduit openings with plugs included in the foundation delivery.
- Lift the foundation into the installation pit. You can use the attachment bar embedded in the foundation as a lifting point. Make sure that the mounting bar is in a direction that enables the installation of the charging station in correct position.
- Put cable conduits into the trenches and install the conduits to relevant inlets.
- Pull electrical cables through the conduits into the foundation.

Figure 2

- Tighten the foundation to its place by filling the excess space outside the foundation with gravel.
- Set the final layer of gravel so that the top of the foundation will be flush with ground or the final paving material.
- Always put a cover plate on the foundation if the charging station is installed in a separate session than the foundation.

Figure 3

- Remove the cover plate before you start the installation work.



Figure 4

- Put the adapter element on the foundation.
- Attach the adapter element to the foundation attachment bar with bolts 3 pcs (included).
- Remove the upper nuts and upper pair of washers from the adapter element. (Make sure that there is one polyamide washer on each side of the mounting box.)
- Pull the supply cable and the possible data cable through the hole in the center of the adapter.



Figure 5

- Put the mounting box on the adapter element.
- Attach the mounting box in place with the washers and the nuts you removed from the adapter element. (Make sure that there is one polyamide washer on each side of the mounting box.)
- Handy hint to adjust the mounting box level: First flip the mounting box upside down and put the nuts under it so that the mounting box is horizontal. Then flip the mounting box over again and tighten the upper nuts and washers.
- **EVTL32.00:** Pull electrical cables through the ground mounting box cable gland(s) approx. 400 mm measured from the upper end of the mounting box.
- **EVTL34.00:** Pull electrical cables through the ground mounting box cable gland(s) and further through the mounting box cable hole approx. 400 mm measured from the upper end of the mounting box.
- Tighten the cable gland. Close the unused cable entries with cable gland plugs.

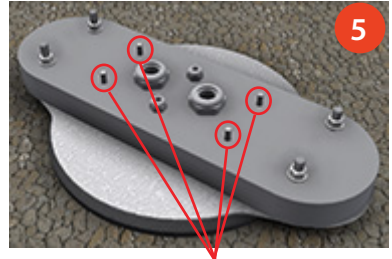

Attach the charging station in correct position with bolts

Figure 6

- Open the maintenance door of the charging station.
- Remove the nuts and washers from the ground mounting box.
- Lift the charging station on the mounting box and pull the electrical cables through the cable hole.
- Attach the charging station in place with the washers and the nuts you removed from the ground mounting box.
- **EVTL32.00:** Remove the supply cable sheath at the length of max. 200 mm.
- **EVTL34.00:** Remove the supply cable sheath beginning from the cable gland exit.
- Cut the supply cable conductors to applicable lengths. The earth conductor must be long enough, so that if a fault occurs it is the last one that comes loose.
- Strip the supply cable conductors 25 mm.
- Connect the supply cable conductors to the supply terminal blocks.
- Make sure that the PE is connected to the charging station.
- Make sure that there are not any loose connections (connectors or conductors) in the charging station.
- Switch on F0, F1, F2 (if present) and QF1.
- Close the maintenance door.

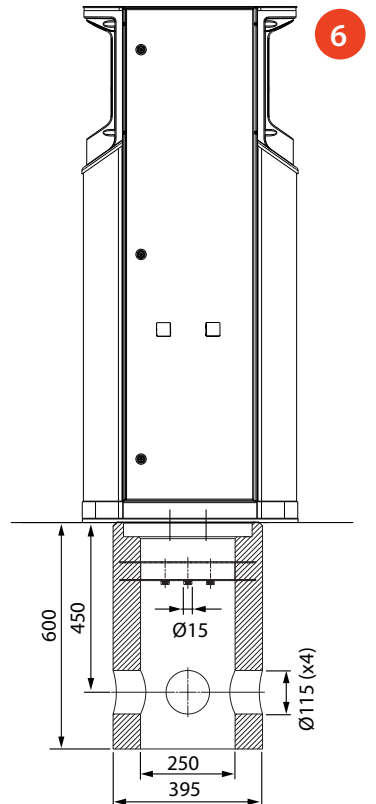

7.6. EVF300 mounting on concrete casting at site

Installation accessories	Ground mounting box EVTL35.00	1 pc
	Anchor bolts M12	8 pcs
	Washers	
	Nuts	

Make sure that the materials used for the concrete foundation and the installation procedures follow local building regulations and safety standards.

- Dig a trench for cable conduits and an excavation pit for the concrete foundation. The pit floor should be compacted and level.
- Install the cable pipes for supply and output chaining. If necessary, install the cable pipe for the data cable and drain pipes in place.
- Fill the pit with concrete.
- Let the concrete cure, make sure the surface stays level during the process.

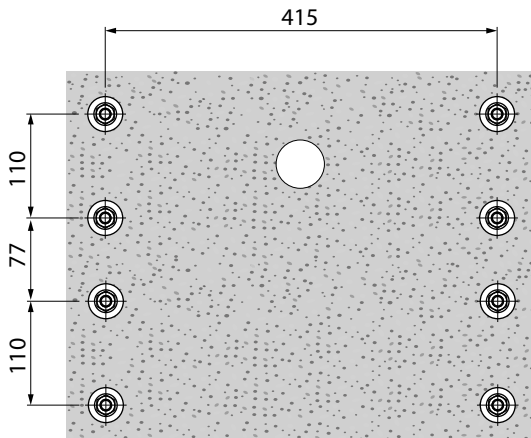
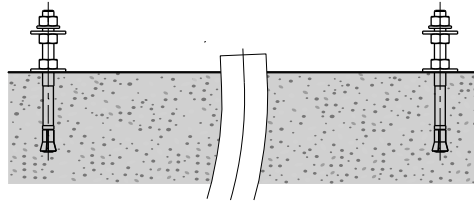

Installation steps

1. Drill a hole in the concrete for the anchor bolts. For more information see the anchor bolt instructions. Use the ground mounting box as a jig.
2. Put the anchor bolts in place and tighten the anchor bolt nuts.
3. Adjust the upper nuts and washers on the anchor bolts horizontally. Use a spirit level.

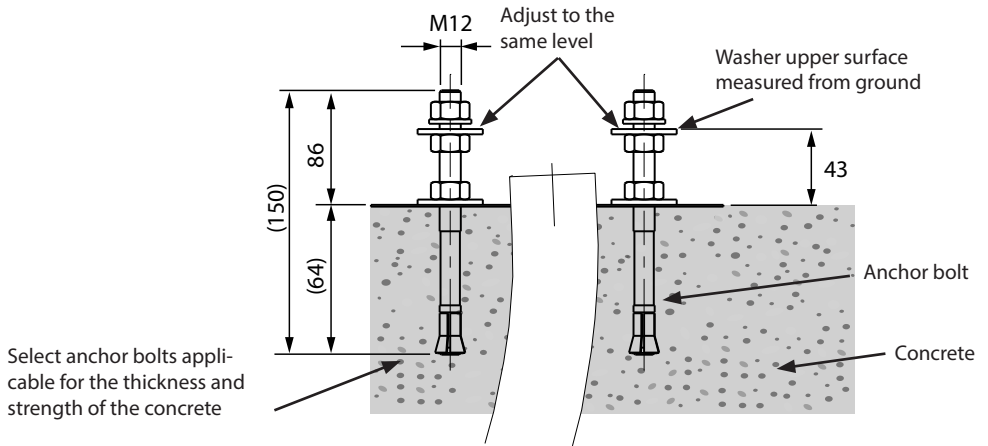

4. Attach the mounting box to the anchor bolts with applicable washers and nuts.
5. Pull electrical cables through the ground mounting box cable gland(s) approx. 450 mm measured from the upper surface of the mounting box.
6. Tighten the cable gland(s). Close the unused cable entries with cable gland plugs.

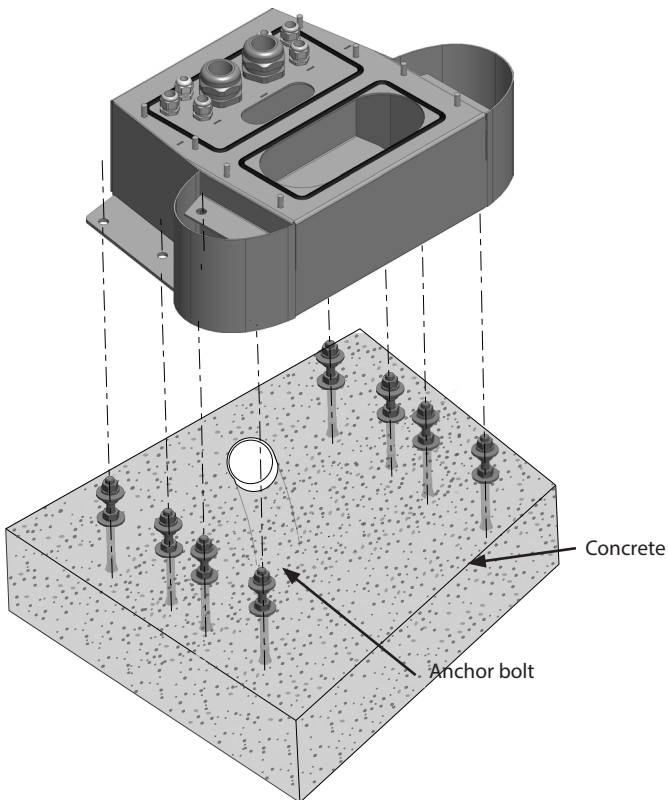

7. Remove the nuts and the washers from the ground mounting box.
8. Open the maintenance door of the distribution cabinet.
9. Lift the distribution cabinet module on the mounting box and attach it in place, max. tightening torque 14 Nm.
10. Remove the supply cable sheath at the length of max. 200 mm.
11. Cut the supply cable conductors to applicable lengths. The earth conductor must be long enough, so that if a fault occurs it is the last one that comes loose.
12. Strip the supply cable conductors 25 mm.
13. Connect the supply cable conductors to the power terminals in the distribution cabinet.
14. Make sure proper strain relief to the cable by fastening the cable with e.g. MUPRO EuroQuick. Select an applicable strain relief according to the cable diameter.
15. Connect the supply to the charging points with intervening connection cables. The intervening connection cables are pre-connected to the the power terminals in the distribution cabinet.

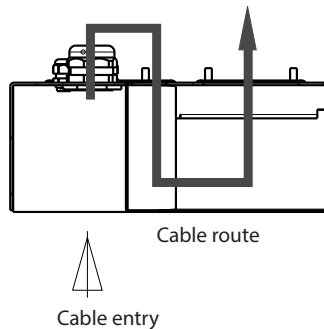

16. Pull the intervening connection cables first down through the mounting box hole on the distribution cabinet side and then up through the mounting box hole on the charging point side.
17. Open the maintenance door of one charging point.
18. Lift the charging point module on the mounting box and attach it in place with bolts, max. tightening torque 14 Nm.
19. Connect the intervening connection cable conductors to the supply terminal blocks located in the maintenance space of the charging point, max. tightening torque 12 Nm.
20. Make sure that the PE is connected to the charging point.
21. Make sure that there are not any loose connections (connectors or conductors) in the charging station.
22. Switch on F0, F1, F2 (if present) and QF1.
23. Install the other charging point module accordingly.
24. Attach the top cover plate on the charging station modules with the washer and the screw included in the delivery.
25. Close the maintenance doors.

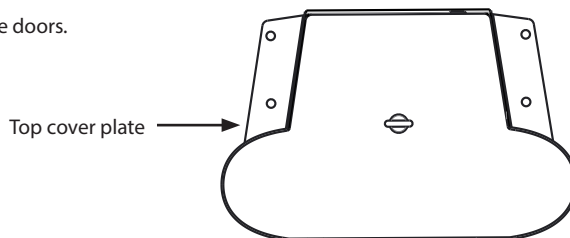

7.7. EVF300 mounting on concrete foundation

Installation accessories	Mounting box EVTL35.00	1 pc
	Adapter for concrete foundation EVTL37.00	1 pc
	Concrete foundation	1 pc

This example describes installation procedure when using a concrete foundation supplied by Sähkö-Jokinen Oy, product code SJR-08.

If you want to use a foundation manufactured by another supplier, make sure that the foundation is compatible with the adapter.

- Plan the installation depth so that the top surface of the adapter is above the ground surface. Take into consideration the possible paving materials.
- Dig a trench for cable conduits and an excavation pit for the concrete foundation to applicable depths.
- Lift the foundation into the pit.
- Put cable pipes for supply and output chaining and, if necessary, the cable pipe for the data cable into the ground. Install the pipes in relevant inlets.
- Close the unused inlets with plugs.
- Tighten the foundation to its place by filling the excess space outside the foundation with gravel.

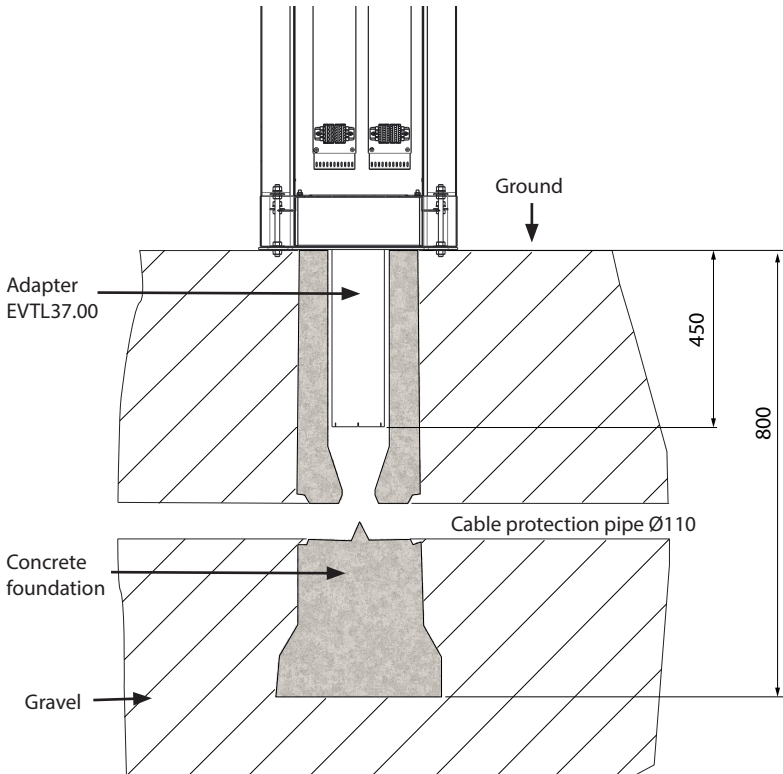

Installation steps

1. Assemble the concrete foundation adapter.
2. Attach the mounting box EVTL35.00 on the concrete foundation adapter EVTL37.00 and put the assembly on the concrete foundation.
3. Attach the assembly in place. Use the screws on the concrete foundation.
4. Pull electrical cables through the ground mounting box cable gland(s) approx. 450 mm measured from the upper surface of the mounting box.
5. Tighten the cable gland. Close the unused cable entries with cable gland plugs.
6. Open the maintenance door of the distribution cabinet.
7. Lift the distribution cabinet module on the mounting box and attach it in place, max. tightening torque 14 Nm.
8. Remove the supply cable sheath at the length of max. 200 mm.
9. Cut the supply cable conductors to applicable lengths. The earth conductor must be long enough, so that if a fault occurs it is the last one that comes loose.
10. Strip the supply cable conductors 25 mm.
11. Connect the supply cable conductors to the power terminals in the distribution cabinet.
12. Make sure proper strain relief to the cable by fastening the cable with e.g. MUPRO EuroQuick. Select an applicable strain relief according to the cable diameter.
13. Connect the supply to the charging points with intervening connection cables. The intervening connection cables are pre-connected to the power terminals in the distribution cabinet.

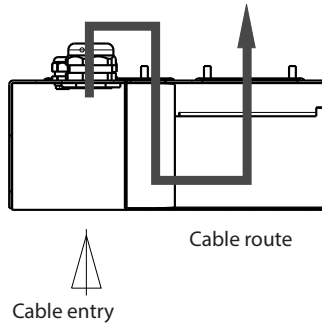

14. Pull the intervening connection cables first down through the mounting box hole on the distribution cabinet side and then up through the mounting box hole on the charging point side.
15. Open the maintenance door of one charging point.
16. Lift the charging point module on the mounting box and attach it in place with bolts, max. tightening torque 14 Nm.
17. Connect the intervening connection cable conductors to the supply terminal blocks located in the maintenance space of the charging point, max. tightening torque 12 Nm.
18. Make sure that the PE is connected to the charging point.
19. Make sure that there are not any loose connections (connectors or conductors) in the charging station.
20. Switch on F0, F1, F2 (if present) and QF1.
21. Install the other charging point module accordingly.
22. Attach the top cover plate on the charging station modules with the washer and the screw included in the delivery.
23. Close the maintenance doors.

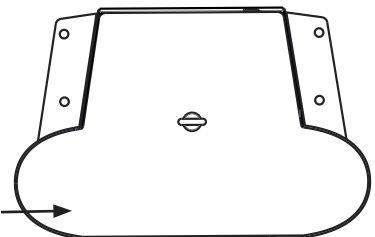

8. Supply connections

The voltage and current ratings including cables and line protector dimensioning must comply with national regulations. System dimensioning must be done by a qualified electrical designer.

EVF200 - TN / TT network

Separate supply cables for each charging point

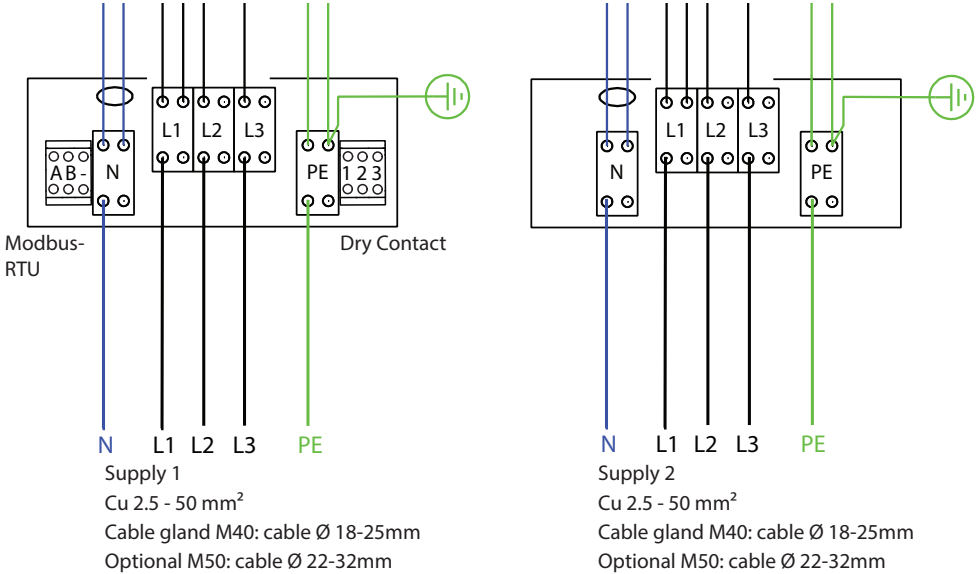

EVF200 - TN / TT network

One supply cable, which is chained internally to the charging points

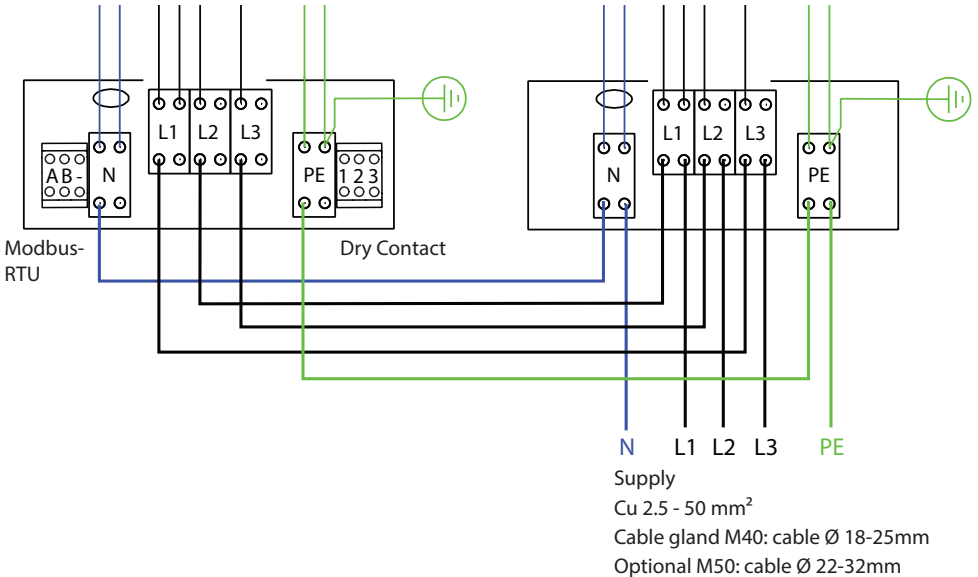

EVF200 - IT network

Separate supply cables for each charging point

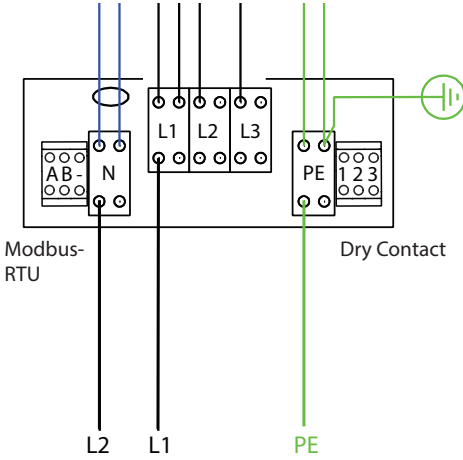

Supply 1

Cu 2.5 - 50 mm²

Cable gland M40: cable Ø 18-25mm

Optional M50: cable Ø 22-32mm

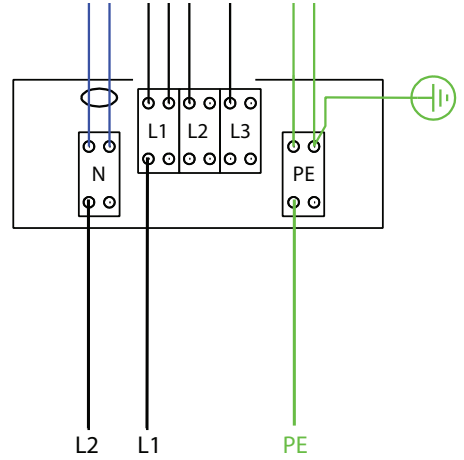

Supply 2

Cu 2.5 - 50 mm²

Cable gland M40: cable Ø 18-25mm

Optional M50: cable Ø 22-32mm

EVF200 - IT network

One supply cable, which is chained internally to the charging points

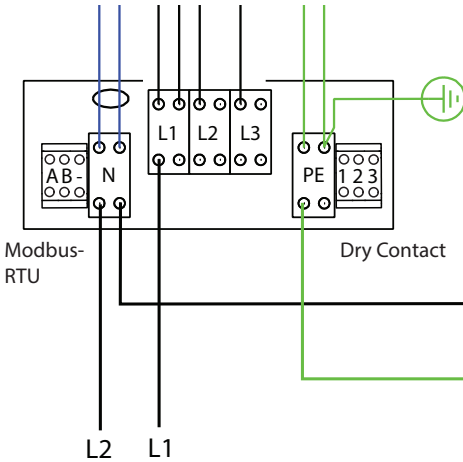

Supply

Cu 2.5 - 50 mm²

Cable gland M40: cable Ø 18-25mm

Optional M50: cable Ø 22-32mm

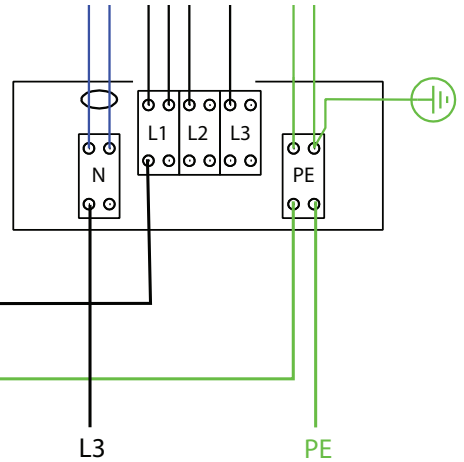

EVF300 Internal Circuit, Main Board Example

The distribution cabinet is delivered empty.

The layout and contents varies depending on local needs and requirements.

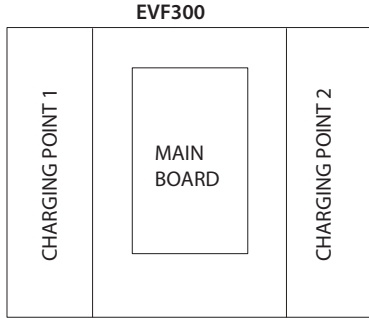

EXAMPLE OF LAYOUT

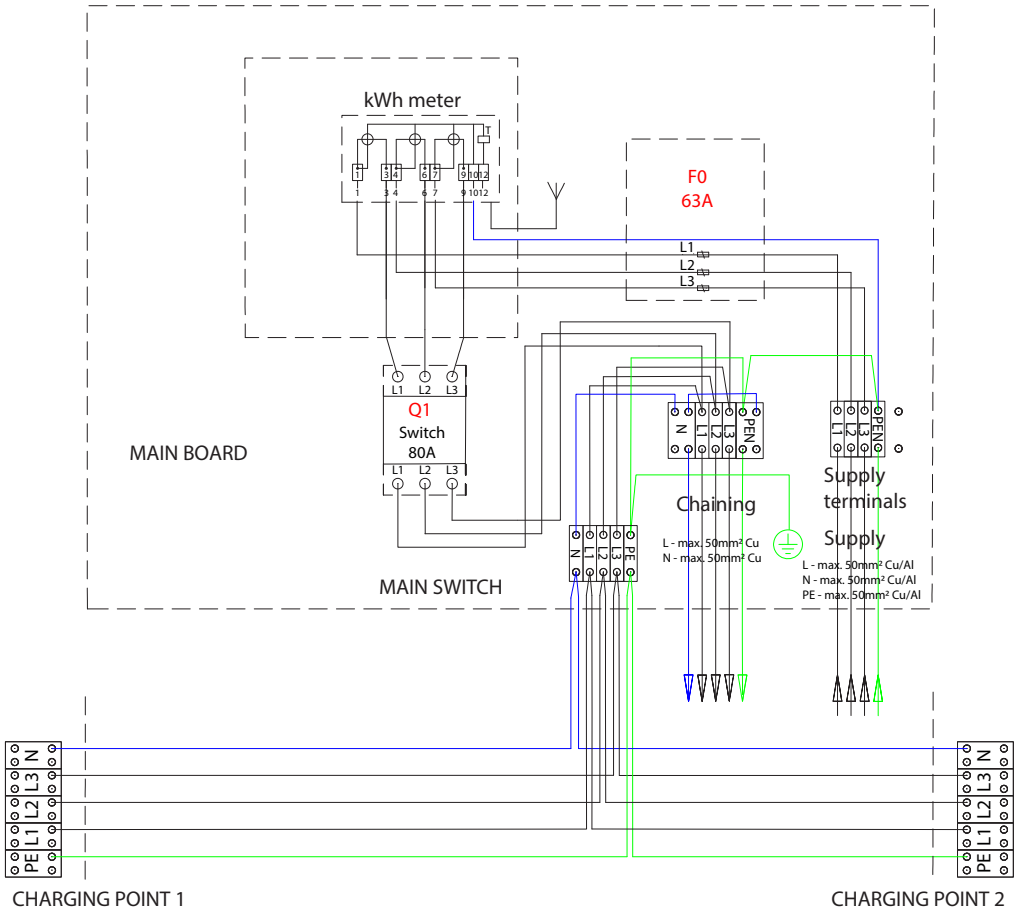

NOTE! If phase rotation is necessary, it can be done with charging point 1 and 2 supply terminals (L1, L2, L3). The phase rotation must be done in accordance with the electrical plan.

9. Commissioning

Before commissioning the charging station must be installed according to the installation instructions.

By default all charging stations are operating in free charging mode (standalone operation). In this free charging mode external communication (Ethernet, 4G, LAN or WiFi) is not active. If you connect the charging station to some back-office (online mode), first make sure that the basic functionality is working before establishing communication.

9.1. External connection terminals

Modbus-RTU:

External energy meter connection (Load Management)

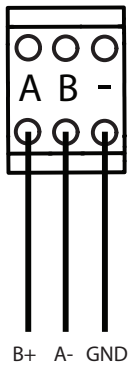

Dry Contact:

Switch / relay

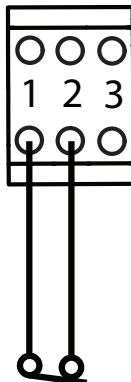

- The input on the charging station end is based on so called dry contact terminal Normally Open / Normally Closed (NO / NC).
- This is configurable via the charging station settings.
- The charging station supplies the input terminal with +12V (logic high DC 11,4V ... 25,2V; logic low 0V) and detects if the dry contact terminal is open or closed.

9.2. View of the component layout on the control unit

Control unit on the left side (Master controller)

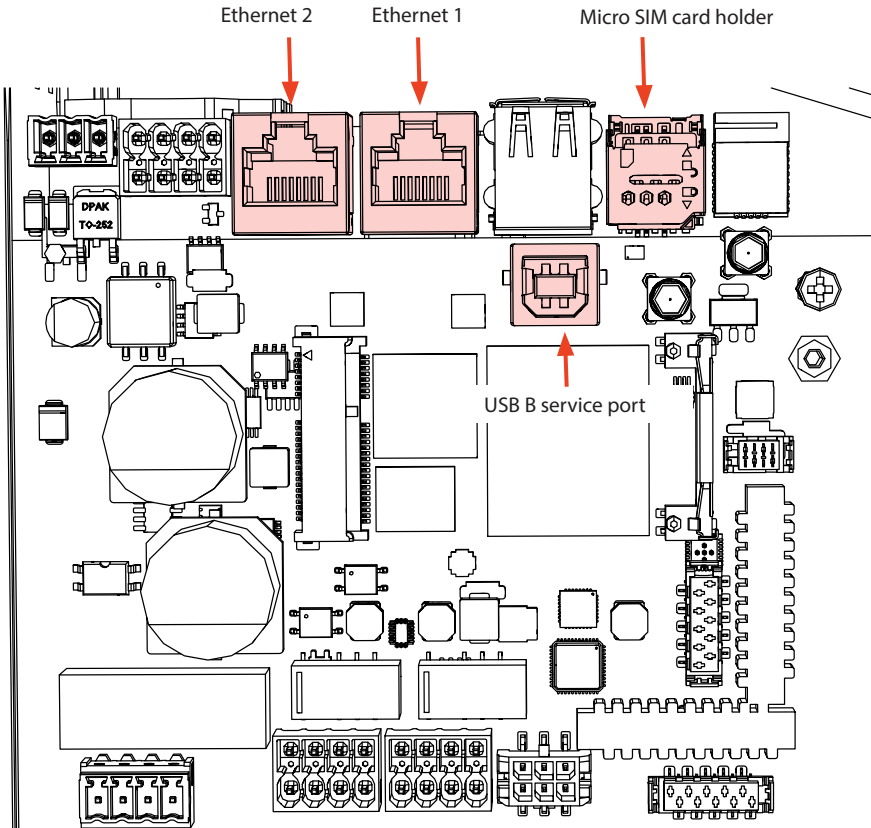

Do not remove any pre-installed USB devices from the controller units!

Connections to the control unit components

Component	Connection	Note
USB B Service port	Computer to the charging station	Connect to the control unit on the right side.
Ethernet 1 / 2	Ethernet communication cable	Connect the input to the control unit on the left side. Ethernet 1 and 2 ports are interchangeable.
Micro SIM card holder	Connection to mobile network	The holder is on the control unit on the left side

9.3. Connecting to the charging station

If you want to change the default settings, you must connect to the charging station via USB cable to web browser to be able to start configure the commissioning settings. Use Firefox, Chrome or Windows Edge web-browser for configuring.

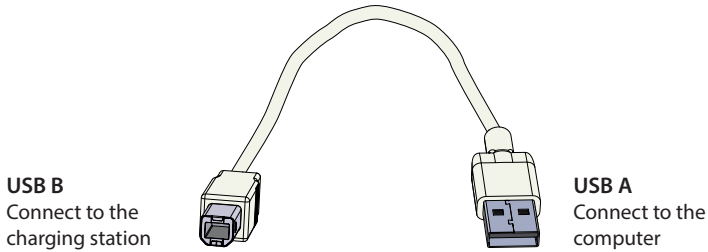

9.4. Ethernet connections

The Internet connection can be established with 4G, Ethernet or WiFi.

Daisy chaining the Ethernet connections is allowed.

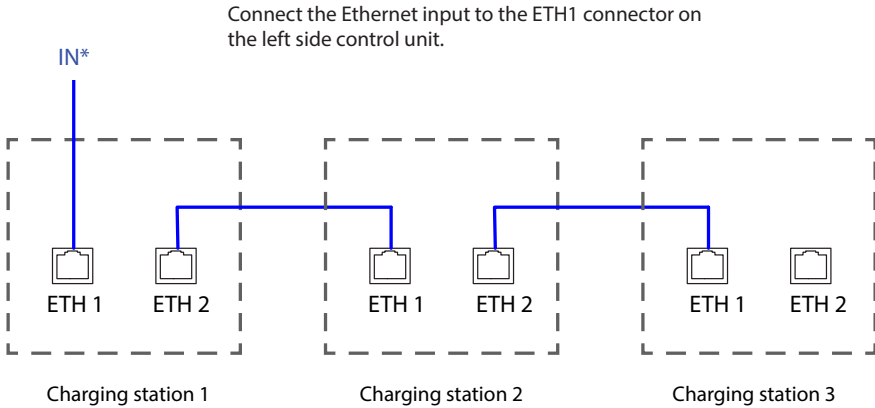

*Take into account that STP (Cascading Switches) is enabled in the Ethernet switch or disable the STP on the charging station.

9.5. WiFi coverage area

A charging station can be connected to local WiFi network as Client Mode or Access Point mode. In Access Point mode max. 20 charging stations can be connected.

The Internet connection can be established with 4G, Ethernet or WiFi.

Please contact your Legrand representative for detailed information.

Examine the available signal strength to make sure that the communication (4G, WiFi), reception and connectivity are working.

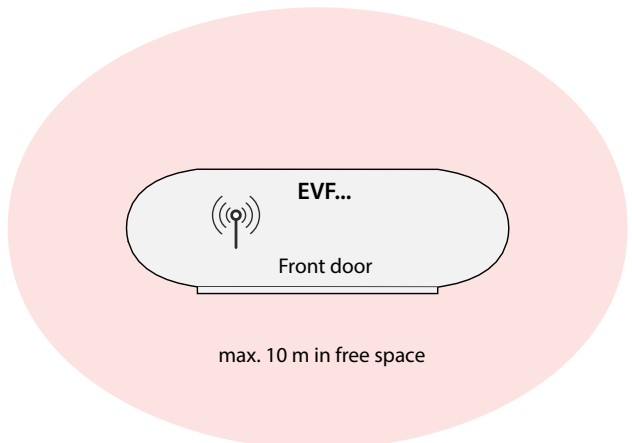

If you want to use a WiFi network, first do a WiFi survey to make sure that the network works correctly. The survey helps you to identify potential issues and optimize coverage.

General steps how to do a WiFi survey

1. Plan the survey.
Define the purpose of the survey: estimate coverage, identify dead spots, optimize performance etc. Define the survey areas, including indoor and outdoor spaces.
2. Collect necessary tools.
Get a WiFi survey tool or software. There are various free and commercial options available, such as Ekahau, NetSpot and Acrylic Wi-Fi Home.
3. Prepare the survey environment.
Make sure that the WiFi network is working. Make sure that in the survey area are not any objects or interference sources that may affect signal propagation, such as large metal objects or other electronic devices.
4. Configure survey settings.
Set the parameters in the survey tool based on your requirements. Select the appropriate frequency bands (2.4 GHz), set the channel width and specify the survey duration.
5. Do the survey.
Walk through the survey area by following a systematic path, while the survey tool records the WiFi signal strength and other relevant data. Take note of the specific locations where measurements are taken.
6. Analyze the survey data.
After the survey is completed, use features of the survey tool to analyze the collected data. Look for areas with low signal strength, high interference, or excessive co-channel and adjacent-channel interference. Identify potential sources of interference or coverage gaps.
7. Take corrective measures.
Based on the survey results, take necessary actions to optimize the WiFi network. You may have to adjust access point placement, modify channel assignments, install additional access points or install additional repeaters to improve coverage.
8. Repeat the WiFi survey if necessary.
If important changes are made to the network infrastructure or if you want further optimization, do additional surveys to evaluate the effectiveness of the modifications.

To get accurate results use professional tools which are intended for WiFi surveys. We recommend that you consult with a wireless network specialist or professional if you want in-depth analysis or troubleshooting assistance. Take into consideration that the WiFi environment is by nature changing, so it can change during the life cycle of the charging system.

10. Technical data

Electrical connections	EVF200 / EVF300
Nominal supply voltage	3-ph, 400 VAC (1-ph, 230 VAC: It is not possible to test the RCD with the test button, use a Type 2 socket test adapter)
Nominal frequency	AC 50 Hz
Nominal supply current	3× 63A
Charging power (nominal)	22kW per charging outlet, 2x 3 x 32A
Idle power loss (load is not connected Control Pilot state A)	approx. 13 W
Supply connections and terminals	L1, L2, L3, N, PE Cu 2.5–50 mm ² (according to supply current and local regulations) Tightening torque: 4 Nm (2.5 - 4 mm ²), 10 Nm (6 - 50 mm ²)
	Cable gland M40: cable Ø 18-25mm Optional M50: cable Ø 22-32mm
Grid connections	TN (3-ph, 1-ph) / IT (2-ph, 230Vp-p)

* Supply voltage range 360 ... 460 V.

Please note that typically electric vehicles do not tolerate more than 7 volts of fluctuation in the main voltage.

Design and mechanics	EVF200 / EVF300
Material	Painted aluminium and stainless steel
Color	RAL9016S "Traffic White"
Weight	EVF200B-A4BC: approx. 41 kg EVF200B-B4BC: approx. 42 kg EVF300: approx. 68 kg (distribution cabinet empty)
Ingress Protection	IP54
Impact resistance	IK10
Operating temperature	-25 °C ... +50 °C
Environmental service conditions	Outdoor use
EV supply equipment classification	Equipment for locations with non-restricted access
Mechanical resistance for stationary assembly	High resistance
Resistance of insulating materials to abnormal heat and fire	Glow-wire test at 650degC as defined by IEC 60695-2-10

Design and mechanics	EVF200 / EVF300
Relative humidity during operation	95 %, non-condensing
Operating altitude	Up to 2000 m
Storage	-40 °C to +70 °C, humidity < 95 %, non-condensing, enclosed storage
Overvoltage Category	OVC III
Standard	EN IEC 61851-1:2019, general requirements for electric vehicle conductive charging system
Approvals	CE

Safety features	EVF200 / EVF300
Over current protection (MCB)	32 A (C-curve)
Residual current protection (RCD)	Type A (30mA AC)
Residual current detection (RCD-DD)	Integrated 6mA DC
Overvoltage and undervoltage protection	Configurable
Control voltage	12 VDC
Temperature control	High operating temperature, such as direct sunlight, can cause reduced charging current or temporary interruption in the charging procedure
Welding detection	Detection of faulty closing of the contactor contacts
PE monitoring	<p>Checking the connection between the control unit and PE</p> <ul style="list-style-type: none"> PE monitoring does not replace the tests that are described in chapters 13. Installation / Commissioning checklist and 14. Maintenance / Preventive maintenance instructions
Emergency opener	In the event of a power failure, the plug of the charging cable is automatically unlocked so that the user can remove it. The emergency opener is integrated as a circuit on the controller of the charging station.
Tamper detection	The charging station sends an OCPP notification message to the backend system when the door is opened. This does not prevent charging.
Optional features	<p>Remotely controlled and monitored RCD automatic reclosing device (ARD)</p> <ul style="list-style-type: none"> Default in EVF200B-B4BC models If the RCD is triggered, the charging cable must first be disconnected from the charging station. The charging station tests the circuit and if no fault is detected the RCD is reset automatically. <p>Surge protection device (SPD)</p> <ul style="list-style-type: none"> Default in EVF200B-B4BCD models According to connection type 1 "CT1" (IEC 60364, clause 534) SPD Legrand catalogue reference 412233

User interface	EVF200 / EVF300
Socket outlet	Mode 3, Type 2 <ul style="list-style-type: none"> The use of adapters or conversion adapters to connect a charging cable to the charging outlet is not allowed. The use of cord extension sets to extend the charging cable range is not allowed.
Charging status indication	3-color LED <ul style="list-style-type: none"> Green / Available Blue / Charging Red / Error
Simultaneous users	2 users
Use access and control	RFID (ISO/IEC 14443A) Free access Mobile apps via 3rd party operators ISO15118 (Plug & Charge support)
Energy measurement	MID class B energy meter according to EN50470-3 (per charging point) See details in energy meter manufacturer's documentation.

Control and communication	EVF200 / EVF300
Operation mode	Standalone / Online
Wireless	4G/LTE WiFi 2.4 GHz (IEEE802.11b/g/n) <ul style="list-style-type: none"> Encryption is based on WPA2-PSK (CCMP) 2 radios (hotspot and client simultaneously)
Wired	LAN / Ethernet
Protocol	OCPP1.6-JSON
Dynamic Load Management (DLM)	Local, embedded software feature over IP Protocol

Sustainability data	
PEP ecopassport (Product Environmental Profile)	PEP Designation https://register.pep-ecopassport.org/pep/consult <ul style="list-style-type: none"> the PEP number will be available soon
SVHC (Substances of Very High Concern)	SCIP is the database for information on Substances of Concern In articles as such or in complex Products established under the Waste Framework Directive (WFD) <ul style="list-style-type: none"> Search related SVHC article ("Ensto Pro EV charging station") from the link https://echa.europa.eu/scip-database

12. Installation / Commissioning checklist

Introduction

Examine the mechanical and electrical installation in accordance with this checklist to make sure that the charging station is properly installed.

Checking the Installation



Examine the visual, mechanical and electrical installation when the charging station is de-energized.

CATEGORY	X	ITEM
Overall look		You have received the ordered material.
		You have removed the protective plastic wrapping.
		You do not see any scratches or damages.
Mechanical installation		The charging station is mounted properly on the installation site.
Electrical installation		The charging point's power supply capacity meets electrical planning (cable size, protective devices...). Review the local electrical design plan.
		The PE-cable screw is tight.
		The power supply conductors (L1, L2, L3, N and PE) are properly connected.
		The insulation of the power supply cable and the conductors (L1, L2, L3, N and PE) is intact.
		The voltage between PE and N is less than 10 V.
		The PE conductor resistance is less than 3 Ω.
Operational check		All the LED states / colors (green, blue, red) and the RFID reader are functioning. <ul style="list-style-type: none"> Use a car simulator. Create fail and charge. Red at bootup, green at idle and blue while charging.
		Test the functionality of the electric protective device (RCD). <ul style="list-style-type: none"> The RCD has tripped in time even though there is a delay in the error (red) recognition. On charging stations where the RCD automatic reclosing functionality (ARD) is available, make sure that the automatic reconnection locking lever is in ON position by switching it first to OFF position and then again to ON.
Ready for use		The correct SW is in use.
		Correct operating mode <ul style="list-style-type: none"> Standalone Online
		Test the data communication, if it is in use. Examine the available signal strength to make sure that the communication (4G, WiFi), reception and connectivity are working.

11. Cybersecurity

- Ensto branded EV charging stations are designed to meet the essential cybersecurity requirements outlined in Directive 2014/53/EU (EN18031-1,-2:2024).

11.1 Cybersecurity actions

- The manufacturer provides regular firmware updates. To guarantee secure operation it is essential to update the latest firmware. The responsibility to update the charger firmware is under operator/owner/back-office provider.
- By default, the charging stations do not collect personal data and the manufacturer is not liable for personal data handling, this is the responsibility of the operator/owner/back-office provider.
- The following telemetry data is available for authorized charging sessions: Session number, Start date, Start time, Duration, Energy, RFID tag, User name. Connecting this information to personal data is the responsibility of the operator/owner/back-office provider.
- For secure connection between the charging station and back-end encrypted communication must be used (for example secure version of OCPP WebSocket, WSS:/ and https for webUI connection).
- Factory reset erases all collected data and settings.

11.2 Unique access passwords

- Unique access passwords are purposed to access and configure the charging station settings via unit webUI. To comply with cybersecurity standards, unique passwords are generated and set for each individual charging station during the manufacturing process.
- Further, unique passwords are printed and placed in individual envelopes inside the charging station.
- The owner of the charging station is in responsible for safeguarding the valid unit passwords from misuse and ensuring that annual maintenance and other necessary activities to keep the charging station operational can be performed.
- The unique passwords define different user access rights (INSTALLER, OPERATOR) as detailed below.
- The charging station OWNER should change the operator and installer passwords immediately after the installation is completed.
- Password recovery service is available. Defined handling fees will apply. For detailed information, please contact Sales Support.

It is the responsibility of the password holder to protect the password from misuse.

NEVER GIVE YOUR PASSWORD TO AN UNAUTHORIZED PERSON!

11.2.1 INSTALLER password

- Your unique password is in the INSTALLER addressed envelope, which is located inside the charging station delivery box.
- The ELECTRICAL INSTALLER can use the installer password to perform the electrical installation and commissioning of the charging station.
- When the installation and commissioning is completed, the INSTALLER envelope must be given to the charging station owner.

11.2.2 OPERATOR password

- Your unique password is in the OPERATOR addressed envelope, which is located inside the charging station delivery box.
- The OPERATOR has full access to the charging station configuration.
- When the configuring is completed, the OPERATOR envelope must be given to the charging station owner.

12. Dimensional drawings

EVF200

Charging station with two charging points

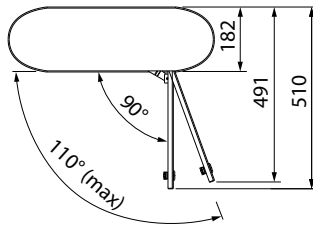
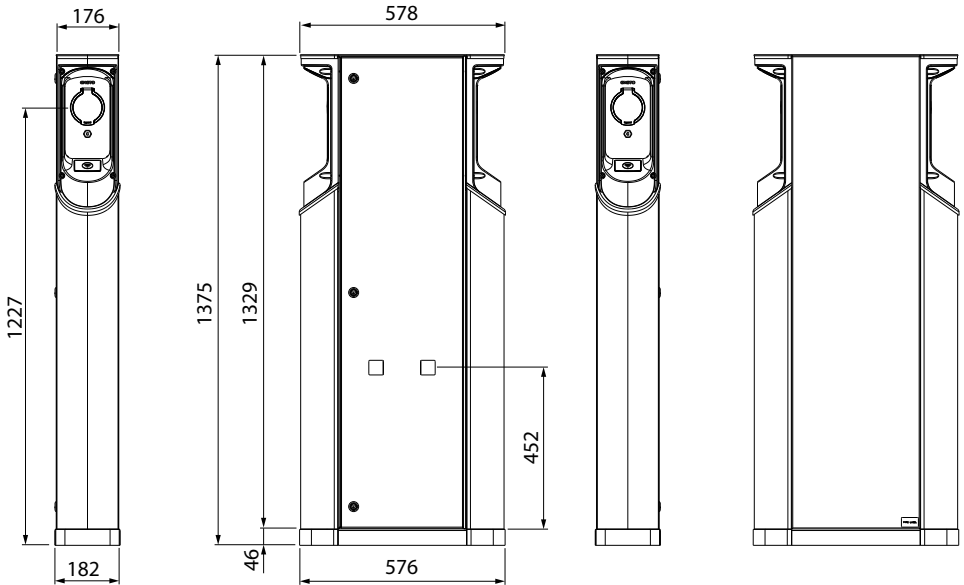

Type label



EVTL32.00 Ground mounting box
(accessory)

EVF300

Charging station with two charging points and a distribution cabinet

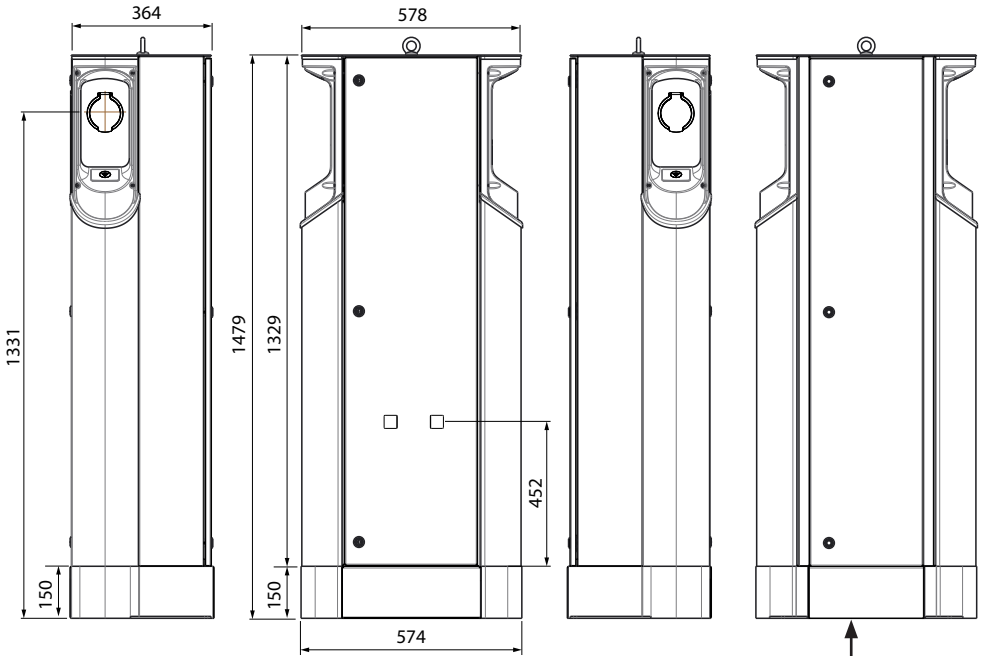

↑
EVTL35.00 Ground mounting box
(accessory)

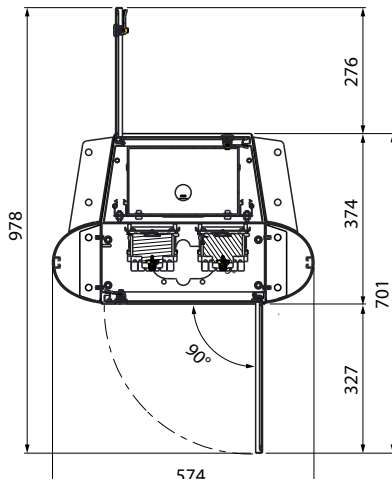

Distribution cabinet	depth 160 mm
Mounting plate inside the cabinet	width 350 mm height 1250 mm

13. Maintenance / Preventive maintenance instructions

Recommended 1 x per year, take into consideration local regulations and national standards.
Protect the charging station against pollution (water, snow, dust).



WARNING

Danger of electrical shock or injury! Risk of fire!

Disconnect power before working inside the device or removing any components.

X	MAINTENANCE ACTION
	Retighten all the screws on electric components.
	Examine the Mode 3 socket for burn or damaged parts. If necessary, replace it (socket cost is not under warranty).
	Examine the charging cable for wear out and mechanical damage. If necessary, replace it.
	Examine the sealings for wear out. If necessary, replace the sealings.
	All the LED states / color (green, blue, red) are functioning. <ul style="list-style-type: none">• Use a car simulator.• Create fail and charge.• Red at bootup, green at idle and blue while charging.
	Make sure that the PE-cable screw is tight.
	Test that the voltage between PE and N is less than 10 V.
	Test that the PE conductor resistance is less than 3 Ω .
	Test the surge arrester, if there is any.
	Check if there are software updates available. Update always the latest version released by the charging station manufacturer.
	Restart the charging station from F0. Make sure that it will restart properly.
	Clean possible dirt and dust from the surface of the charging station. Wipe carefully with a moist cloth.
	Examine the visible metal parts for rust. Apply anti-corrosion agent, if necessary.
	Test the functionality of the electric protective device (RCD) every six months.
	On charging stations where the RCD automatic reclosing functionality (ARD) is available, make sure that the automatic reconnection locking lever is in ON position by switching it first to OFF position and then again to ON .

Maintenance actions done by:

Date:

14. Testing instructions for the electric protective device

- Press the **TEST** button.
- The lever turns to **OFF** position.
- Turn the lever back to **ON** position.
- If a fault occurs, contact an electrician.

1-ph, 230 VAC: It is not possible to test the RCD with the test button, use a Type 2 socket test adapter. The internal wiring of the RCD prevents using the test button in 1-phase installations.

15. Troubleshooting

Charging station is off, no lights on

Issue	Corrective action
Mains voltage does not exist in the supply terminals (L1, L2, L3).	Make sure that the supply conductors are properly connected. Make sure that there is power available.
The circuit breaker F0 is off.	Turn the F0 on.
The PWR LED indicator on the controller is not on.	Make sure that power supply to the controller is available.

Charging cable is locked in Mode 3 socket outlet

Issue	Corrective action
Unexpected fault has occurred while the power is on.	Turn off the power from the F0 and pull the charging cable out from the socket.
The power is off.	Open the front cover. Switch the Mode 3 lock into open position.

The RCD is triggered

Issue	Corrective action
A power failure has occurred.	First pull the charging cable out from the socket. Option 1: <ul style="list-style-type: none">• Turn on the RCD. Option 2: <ul style="list-style-type: none">• On charging stations where the RCD automatic reclosing functionality (ARD) is available, the charging station tests the circuit and if no fault is detected the RCD is reset automatically. If the error occurs again, contact service.

Configuration via web browser

Issue	Corrective action
The PC does not recognize the USB plug and a connection to the controller cannot be established via web browser.	Make sure from Windows operating system settings via "Device Manager" that RNDIS network adapter is available. If not, contact your local IT support.

16. Code key

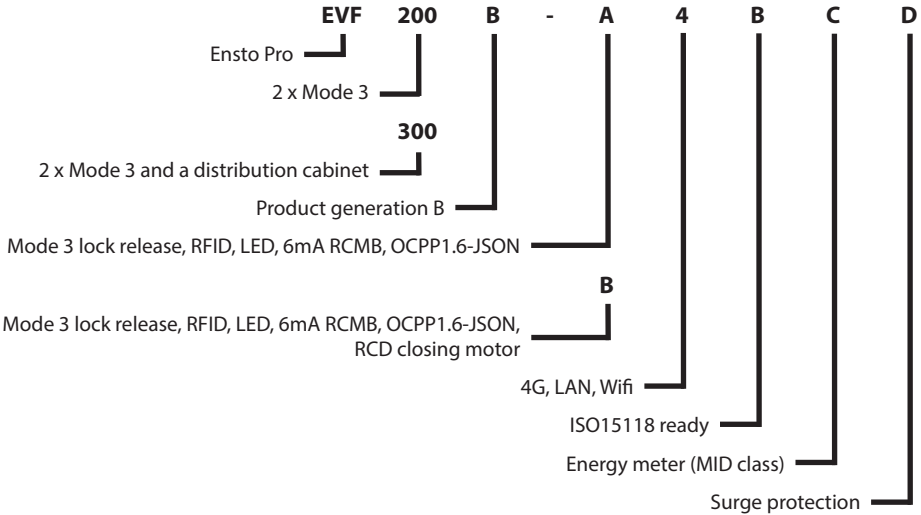

17. Warranty

Warranty conditions, see <https://www.legrand.fi/en/standard-guarantee-and-liability-terms>

18. Declaration of Conformity

Hereby, Legrand Finland Oy declares that the radio equipment Ensto Pro charging station is in compliance with Directive 2014/53/EU. The full text of the EU declaration of conformity is available at the following internet address: <https://www.legrand.fi/en>

19. Disposal











Do not dispose of electrical and electronic devices including their accessories with the household waste.

- When the charging station is at the end of its life cycle, it must be disposed of properly according to local recycling guidelines.
- The cardboard packing of the charging station can be recycled.
- Dispose of the plastic wrap with the household waste or according to local recycling guidelines.

User Guide

20. User interfaces

LED indicator lights will show the status of the charging point as described below:

Charging point's status	LED light	LED operation
The charging point is free and ready to use	Green	Solid 
RFID read, authorization ongoing	Green	Flashing 
Charging authorization rejected	Red	Solid, 3 seconds 
Authorization accepted, charging allowed	Green	Waving 
While you connect the charging cable	Green	Flashing twice 
Your vehicle is connected, charging has not started	Green	Waving 
Your vehicle is connected, but no current flowing (stand-by)	Blue	Waving 
Charging ongoing	Blue	Solid 
Error state	Red	Solid 

21. Charging

21.1. Free charging

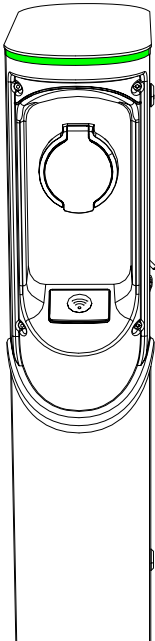

Start charging

When the charging point is free and the LED indicator shows green, you can start a charging event.

- 1 Plug the charging cable to your electric vehicle.
Plug the charging cable to the charging point.
The LED indicator turns to stable blue.

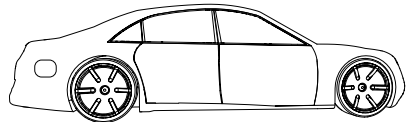
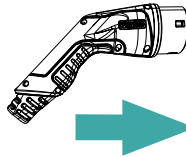

Stop charging

- 2 Unplug the charging cable from the charging point.
Unplug the charging cable from your electric vehicle.
After you have unplugged the charging point is free for the next user.

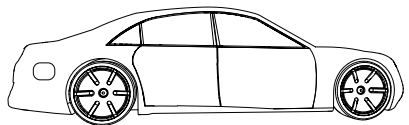
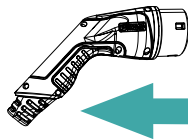

21.2. Charging with RFID

You must have an RFID tag which has a permission to access the charging point.

Start Charging with RFID

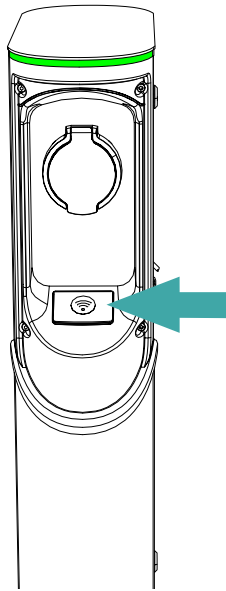

- 1** Plug the charging cable to your electric vehicle.
Plug the charging cable to the charging point.

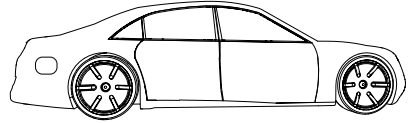
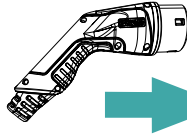

- 2** Show the RFID tag to the RFID reading area.
While the RFID tag is read, the LED indicator flashes green and verifies the user permission to charge.
 - If the user authorization is rejected, the LED indicator turns to solid red for 3 seconds.
 - If the user authorization is accepted, the indicator light turns to waving green.

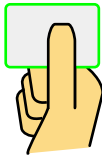

- 3** Charging event starts.
 - The LED indicator turns to stable blue.

Stop Charging with RFID

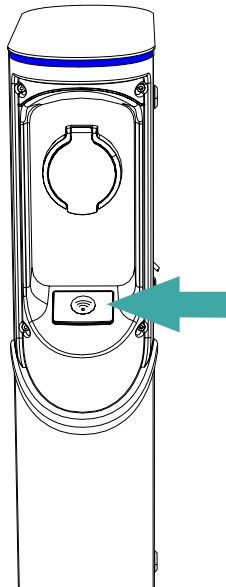

- 4** Show the RFID tag to the RFID reading area.
Charging event ends.
 - The LED indicator turns to waving green.



- 5** Unplug the charging cable from the charging point.
Unplug the charging cable from your electric vehicle.

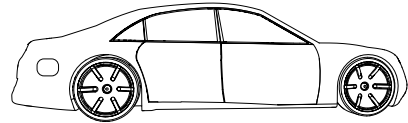
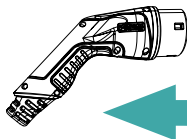



Legrand Finland Oy
Linnoitustie 11,
02600 Espoo, Finland
Tel: +358 20 486 5010
www.legrand.fi

Legrand reserves at any time the right to modify the contents of this booklet and to communicate, in any form and modality, the changes brought to the same.