

2172255	DATA SHEET	
Valid from: 02.12.2024	IE-6-M12XF-S-(L*)-P-4-26-FD-OE	

Description

- Ethernet patchcords Cat.6, shielded
- For industrial ethernet and cable chain
- Straight M12-jack on free conductor end



General characteristics

Connection method, connector	M12x1-jack, x-code
Number of pins	8
Ambient temperature	-30°C to +80°C (-22°F to 176°F) (fixed installation) -30°C to +70°C (-22°F to 158°F) (flexible installation)
Degree of protection	IP 65, IP 67 (M12 –plugged and locked)
Shielding	shielded
Tightening torque	1.0 Nm (M12-connector) 2.0 Nm (M12-flange nut)

Variation

Article	Description	Length (L*) [m]
2173036	IE-6-M12XF-S-0,5-P-4-26-FD-OE	0.5
2172255	IE-6-M12XF-S-1-P-4-26-FD-OE	1
2172256	IE-6-M12XF-S-2-P-4-26-FD-OE	2
2172257	IE-6-M12XF-S-3-P-4-26-FD-OE	3
2172258	IE-6-M12XF-S-5-P-4-26-FD-OE	5
2172259	IE-6-M12XF-S-7-P-4-26-FD-OE	7
2172260	IE-6-M12XF-S-10-P-4-26-FD-OE	10
2172261	IE-6-M12XF-S-15-P-4-26-FD-OE	15
2172262	IE-6-M12XF-S-20-P-4-26-FD-OE	20

Additional note

Data sheet also valid for variant lengths. Other lengths on request.

Electrical properties

Rated voltage	50 VAC / 60 VDC
Rated current at 40 °C	0.5 A
Pollution degree	3 (M12 –plugged and locked)

Transmission characteristics

Category (ISO)	6
----------------	---

Creator: FEL1/PDP Released: IVSE1/PDP	Document: DB2172255EN Version: 02	Page 1 of 3
--	--------------------------------------	-------------

2172255	DATA SHEET	
Valid from: 02.12.2024	IE-6-M12XF-S-(L*)-P-4-26-FD-OE	

Connector pin assignment

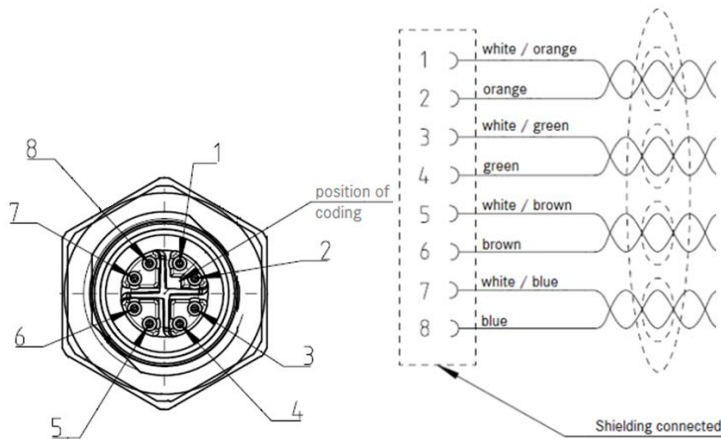

Mechanical properties

M12-jack

Inflammability class according to UL 94

Housing, material
 Contact, material
 Contact carrier, material
 Housing, material
 Handle, material
 Seal outer, material
 Seal inner, material
 Nut, material

TPU → HB
 NBR, FPM/FKM → none
 Cu, nickel plated
 CuNi, gold plated
 TPU, green
 Cu, vernickelt
 TPU, black
 NBR, black
 FPM/FKM, red
 Cu, nickel plated

Line (Lapp article number: 2170488)

Cable construction
 Conductor diameter including isolation
 Cable outer diameter
 Insulation color

4x2x AWG 26 / 19
 0.98 mm
 7.8 mm
 white/blue, blue, white/orange, orange,
 white/green, green, white/brown, brown
 green, similar RAL 6018
 Alufoil (overlapped)
 Braid made of tinned copper wires
 4 x cable outer diameter (fixed installation)
 7.5 x cable outer diameter (flexible installation)

Sheath color
 Type of pair shielding
 Shielding
 Bending radius

1.000.000
 10 m
 4 m/s
 4 m/s²
 63 kg/km
 PUR
 PP
 acc. IEC 60332-1-2
 acc. CSA FT1 und NEC VW-1
 acc. CSA 22.2, 4 days/100 °C (212 °F)

Number of bending cycle
 Traveling distance
 Travel speed
 Acceleration
 Cable weight
 Outer coating, material
 Wire insulation, material
 Flame resistance
 Oil resistance

Creator: FELI1/PDP Released: IVSE1/PDP	Document: DB2172255EN Version: 02	Page 2 of 3
---	--------------------------------------	-------------

2172255	DATA SHEET	
Valid from: 02.12.2024	IE-6-M12XF-S-(L*)-P-4-26-FD-OE	

Standards / Approvals

Product standard, M12-connector IEC 61076-2-109
 Generic cabling for customer premises – General requirements ISO/IEC 11801

Technical drawing

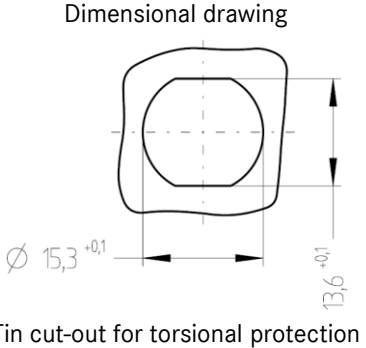
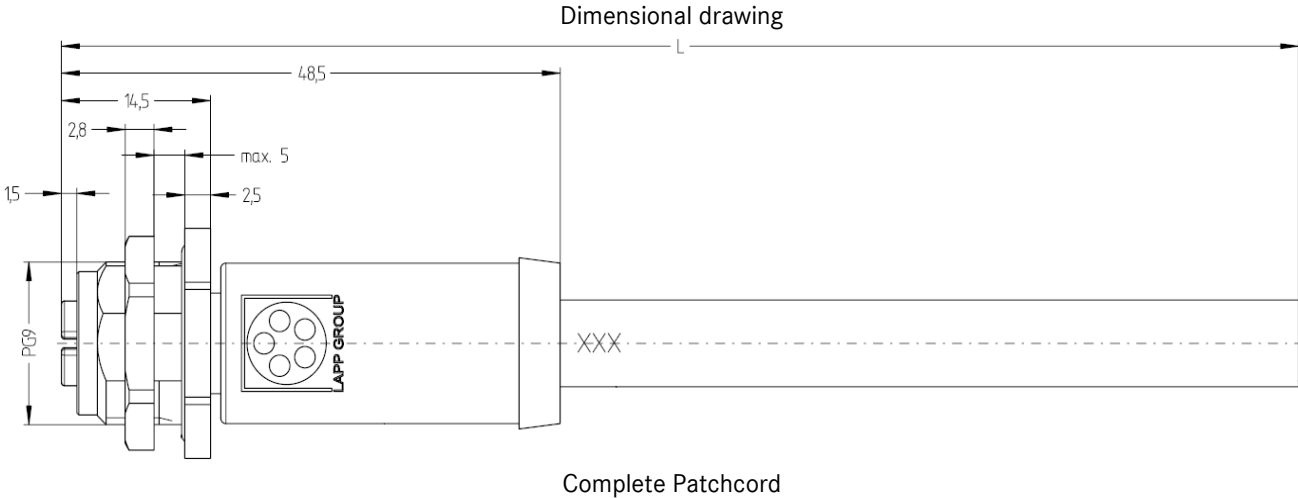
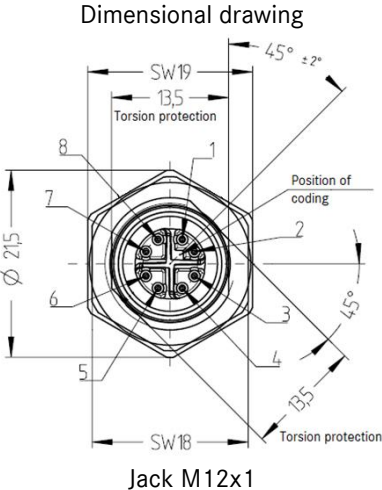

Application range

Automation, industrial machinery and plant engineering

Note

Photographs are not true to scale and do not represent detailed images of the respective products.

Creator: FELI1/PDP Released: IVSE1/PDP	Document: DB2172255EN Version: 02	Page 3 of 3
---	--------------------------------------	-------------

We reserve all rights according to DIN ISO 16016