

44423340	Montageanleitung Assembly instruction	
Gültig ab / valid from 18.08.2020	EPIC® MHB 6 LWL LC EPIC® MHS 6 LWL LC	

- 1 Fertig konfektionierten LWL LC Stecker
ins Modul einführen, bis ein Klick zu hören
ist
*Insert the pre-assembled LWL LC Plugs
into the modul until a click is heard*

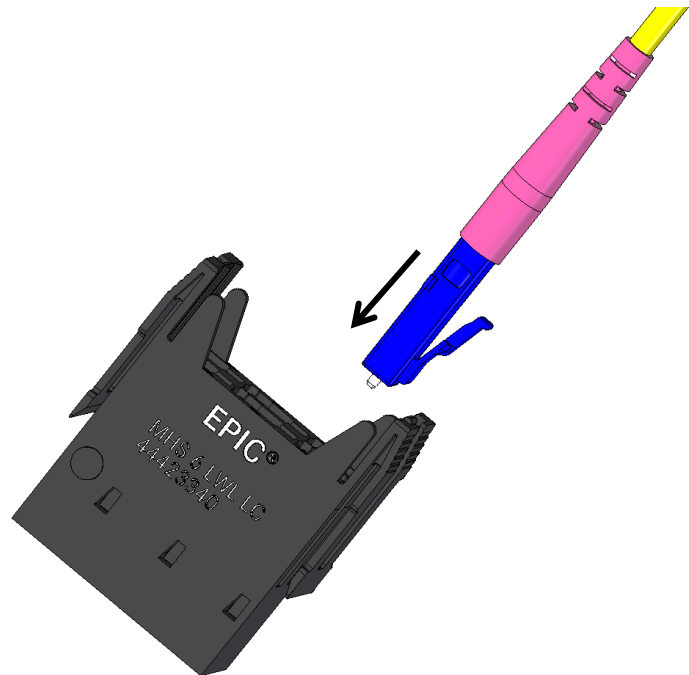

- 2 Module in Rahmen einrasten
Snap the modules into the frame

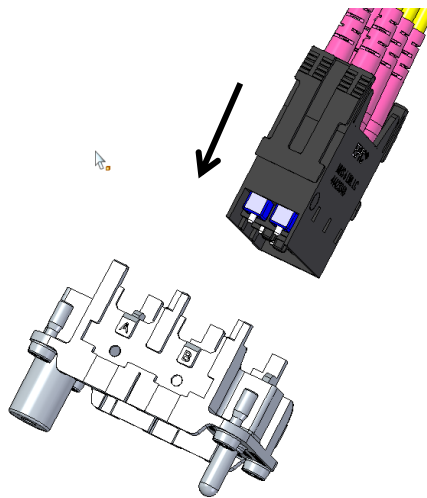

- 3 Codierung ist zu beachten
Coding must be considered

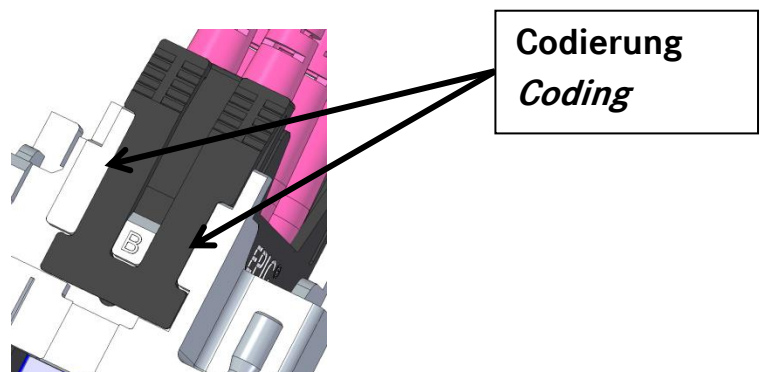

44423340	Montageanleitung Assembly instruction	
Gültig ab / valid from 18.08.2020	EPIC® MHB 6 LWL LC EPIC® MHS 6 LWL LC	

4 Die Striche auf der gleichen Seite
The dashes on the same side

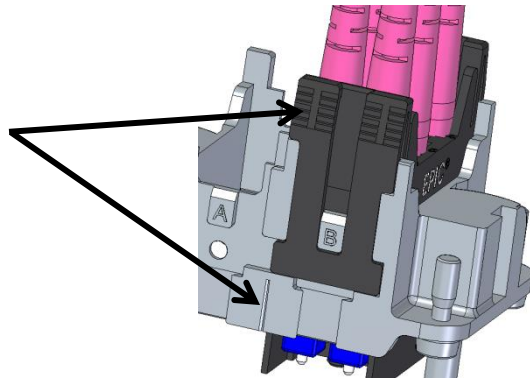

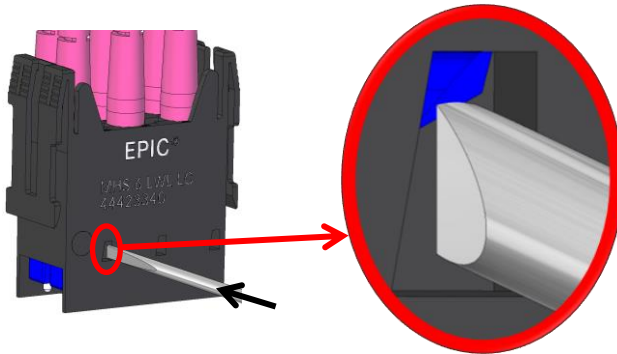

5.1 Seitliche Demontage der eingerasteten LC Stecker mit Schlitz-Schraubendreher ca. 0,5x2
Lateral removal of the engaged LC connectors with a slotted screwdriver

1. Schraubendreher seitlich in die Öffnung schieben.
Push the screw driver from the side into the hole.

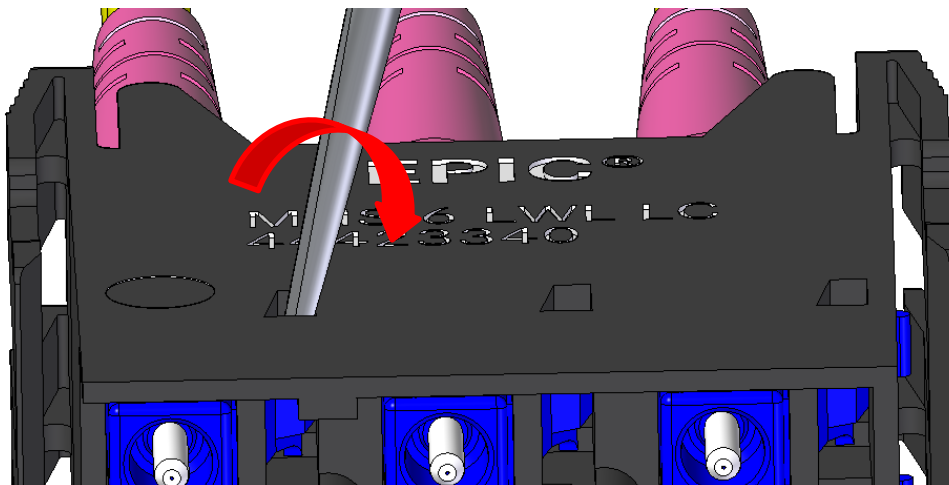

2. Durch seitliches drücken auf den Schraubendreher wird die Verriegelung zurückgedrückt und die LC Stecker lassen sich herausziehen.
By pressing the screwdriver sideways, the lock is pushed back and the LC plugs can be pulled out.



44423340	Montageanleitung Assembly instruction	
Gültig ab / valid from 18.08.2020	EPIC® MHB 6 LWL LC EPIC® MHS 6 LWL LC	

5.2 Demontage der eingerasteten LC Stecker mit Schlitz-Schraubendreher ca. 0,5x2 von der Rückseite (Eingerastetes Modul)
Dismantle the engaged LC connectors with a slotted screwdriver approx. 0.5x2 from the rear (engaged module)

1. Schraubendreher von hinten in die Kontaktkammer einführen.
Insert screwdriver into the contact chamber from behind.

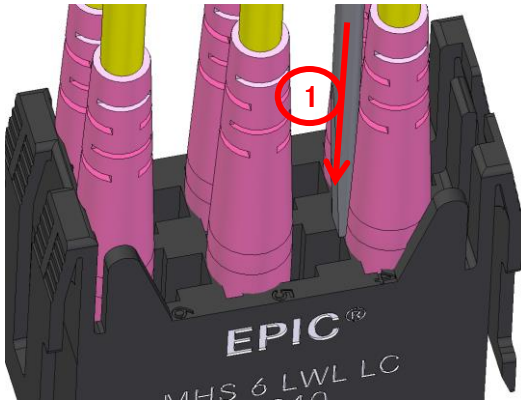

2. Die Verrastung mit dem Schraubendreher in Richtung LC-Stecker zurückdrücken.
Push back the latch with the screwdriver in the direction of the LC connector.

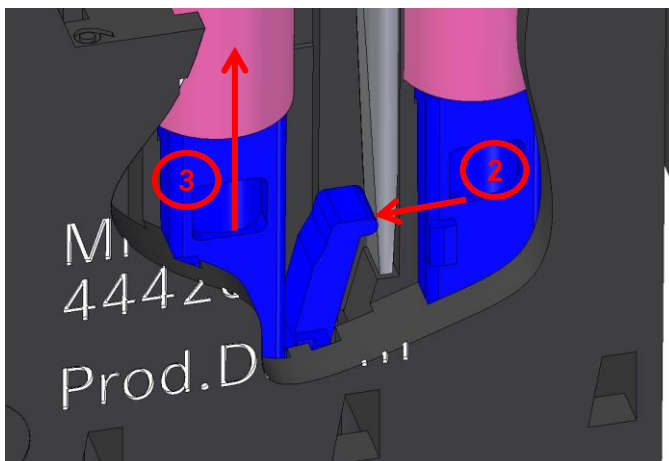

3. Den LC-Stecker nach hinten aus der Kammer ziehen.
Pull the LC plug out of the chamber to the rear.



Die LWL-Glasfaserleiter müssen nach jedem Stecken und Trennen, mit geeigneten Mitteln gereinigt werden.
The LWL-optical fibers must be cleaned after every mating cycle, using proper tools.



44423340	Montageanleitung Assembly instruction	
Gültig ab / valid from 18.08.2020	EPIC® MHB 6 LWL LC EPIC® MHS 6 LWL LC	

Passende LWL Patchcord :
Fitting LWL Patchcords :

GOF DUPLEX Patchcord			
Artikelnummer <i>Material number</i>	Artikelbeschreibung <i>Material description</i>	Type <i>type</i>	Länge: <i>length</i> [m]
29031402	GOF Duplex Patchcord G50 OM4	LC/SC	2
29032402	GOF Duplex Patchcord G50 OM4	LC/ST	2
29033402	GOF Duplex Patchcord G50 OM4	LC/LC	2
29031302	GOF Duplex Patchcord G50 OM3	LC/SC	2
29032302	GOF Duplex Patchcord G50 OM3	LC/ST	2
29033302	GOF Duplex Patchcord G50 OM3	LC/LC	2
29031202	GOF Duplex Patchcord G50 OM2	LC/SC	2
29032202	GOF Duplex Patchcord G50 OM2	LC/ST	2
29033202	GOF Duplex Patchcord G50 OM2	LC/LC	2
29031102	GOF Duplex Patchcord G62.5	LC/SC	2
29032102	GOF Duplex Patchcord G62.5	LC/ST	2
29033102	GOF Duplex Patchcord G62.5	LC/LC	2
29031902	GOF Duplex Patchcord E9 OS2	LC/SC	2
29032902	GOF Duplex Patchcord E9 OS2	LC/ST	2
29033902	GOF Duplex Patchcord E9 OS2	LC/LC	2
29033802	GOF Duplex Patchcord 9/125 APC	LC/LC	2
29039902	GOF Duplex Patchcord SC-APC E9 OS2	LC/SC	2

Module :
Moduls :

EPIC® MHS 6 LWL LC
Art.Nr. 44423340
Polzahl: 6
Number of contacts: 6



EPIC® MHB 6 LWL LC
Art.Nr. 44423341
Polzahl: 6
Number of contacts: 6



44423340	Montageanleitung Assembly instruction	
Gültig ab / valid from 18.08.2020	EPIC® MHB 6 LWL LC EPIC® MHS 6 LWL LC	

Rahmen:
Frame:

Buchsenrahmen: Mit kleinen Buchstaben
gekennzeichnet
Female frame: Marked with small letters

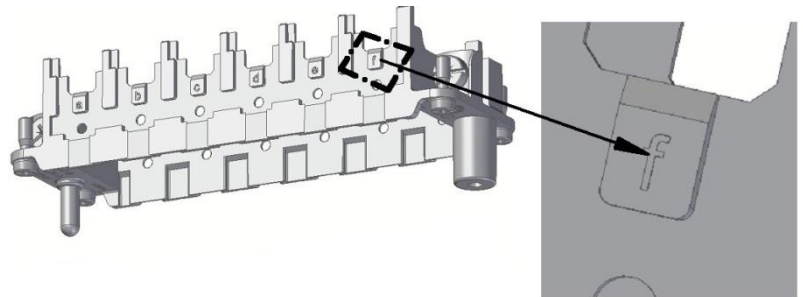

Stiftrahmen: Mit großen Buchstaben
gekennzeichnet
Male frame: Marked with capital letters

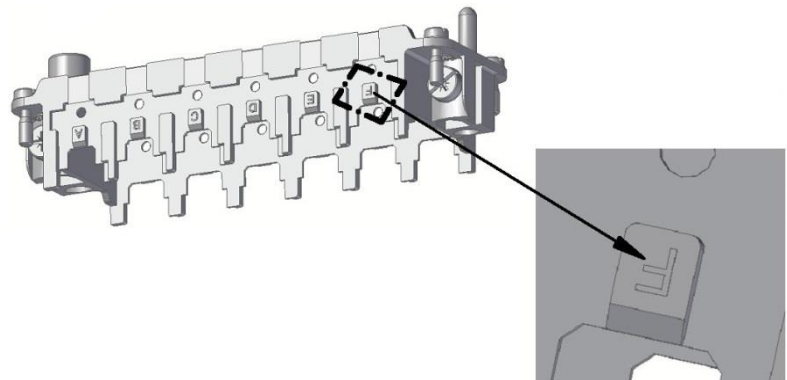

Artikelnummer Material number	Artikelbeschreibung Material description	Kontakttyp Contact type	Slot Slot
EPIC® MH 6 Multirahmen			
44423234	EPIC® MHS 6 R (A, B)	Stift	2
44423235	EPIC® MHB 6 R (a, b)	Buchse	2
EPIC® MH 10 Multirahmen			
44423236	EPIC® MHS 10 R (A, B, C)	Stift	3
44423237	EPIC® MHB 10 R (a, b, c)	Buchse	3
EPIC® MH 16 Multirahmen			
44423238	EPIC® MHS 16 R (A, B, C, D)	Stift	4
44423239	EPIC® MHB 16 R (a, b, c, d)	Buchse	4
EPIC® MH 24 Multirahmen			
44423240	EPIC® MHS 24 R (A, B, C, D, E, F)	Stift	6
44423241	EPIC® MHB 24 R (a, b, c, d, e, f)	Buchse	6



ACHTUNG: UNSICHTBARERE LASERSTRAHLUNG WENN GEÖFFNET
NICHT IN DEN STRAHL BLICKEN
CAUTION: INVISIBLE LASER RADIATION WHEN OPEN
AVOID DIRECT EXPOSURE TO BEAM



U.I. Lapp GmbH
Schulze-Delitzsch-Strasse 25
D-70565 Stuttgart
www.lappgroup.com

Dokument / document: L44423340DE_EN Version / version: 00	Seite 5 von 5 page 5 of 5
--	------------------------------