

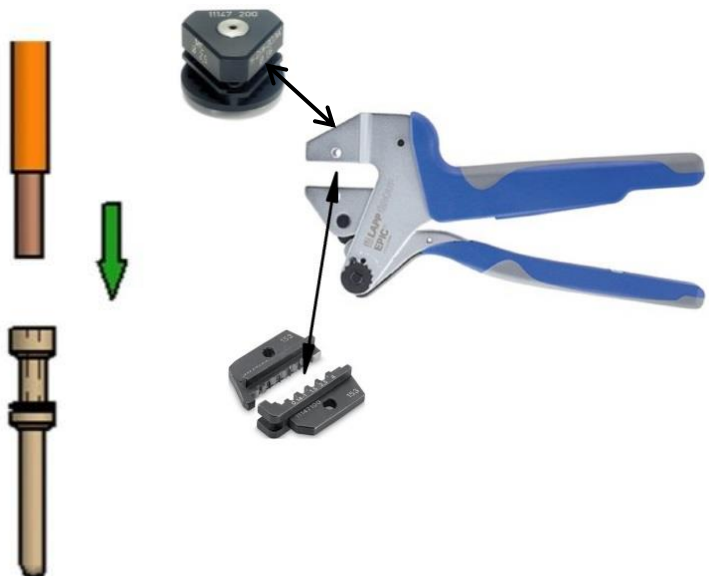

44423364	<b>Montageanleitung</b> <b>Assembly instruction</b>	
Gültig ab / valid from 26.04.2022	<b>EPIC® MHS 2 40A CM</b> <b>EPIC® MHB 2 40A CM</b>	

- 1 Adern abisolieren  
*Strip the wires*  
 Dénuder les conducteurs



- 2 Kontakte crimpen  
*Crimp the contacts*  
 Sertir les contacts



44423364	<b>Montageanleitung</b> <b>Assembly instruction</b>	
Gültig ab / <i>valid from</i> 26.04.2022	<b>EPIC® MHS 2 40A CM</b> <b>EPIC® MHB 2 40A CM</b>	

3. Kontakte ins Modul einführen,  
bis ein Klick zu hören ist.  
Sicheren Halt der Kontakte prüfen.  
*Insert contacts into the modul  
until a click is heard.*  
*Check that the contacts are securely held.*  
Introduire les contacts dans le module  
jusqu'á ce que vous entendiez un déclic.  
Vérifiez que les contacts sont solidement  
maintenus.



44423364	<b>Montageanleitung</b> <b>Assembly instruction</b>	
Gültig ab / valid from 26.04.2022	<b>EPIC® MHS 2 40A CM</b> <b>EPIC® MHB 2 40A CM</b>	

- 4 Module müssen im Rahmen einrasten  
*The modules must snap into the frame*  
 Les modules doivent être insérés dans le cadre

- 5 Schrauben zurückdrehen  
*Screw back the screws*  
 Dévisser les vis

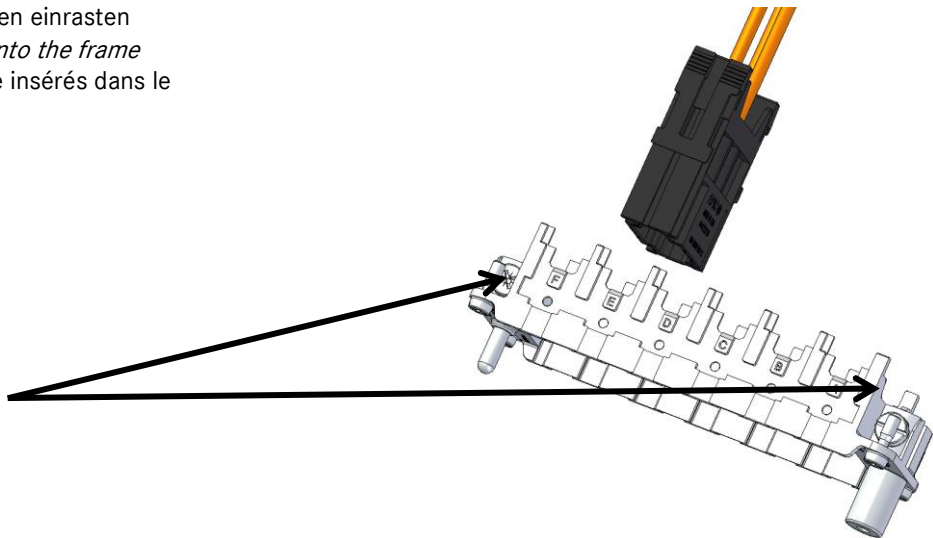

- 6 Codierung ist zu beachten  
*Coding must be considered*  
 Le codage doit être observé

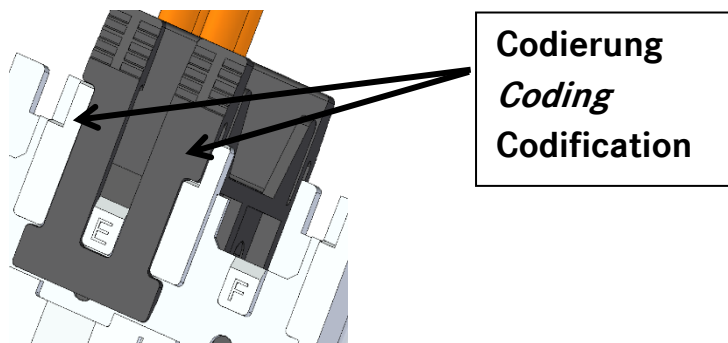

- 7 Die Striche auf der gleichen Seite  
*The dashes on the same side*  
 Les traits sur la même face

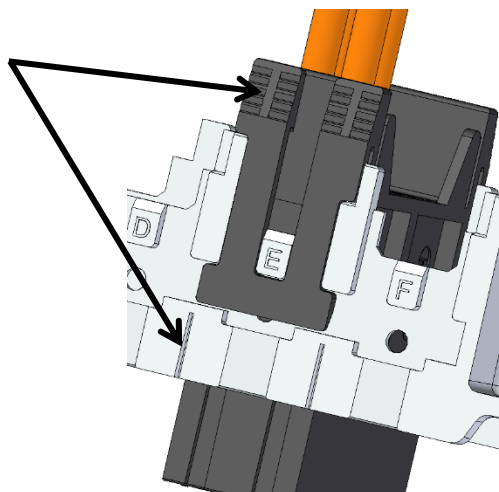

44423364	<b>Montageanleitung</b> <b>Assembly instruction</b>	
Gültig ab / valid from 26.04.2022	<b>EPIC® MHS 2 40A CM</b> <b>EPIC® MHB 2 40A CM</b>	

- 8 Nachprüfen, ob die Module fest eingerastet sind  
*Verify that the modules are fixed*  
 Verifier, si les modules sont bien introduits et fixés

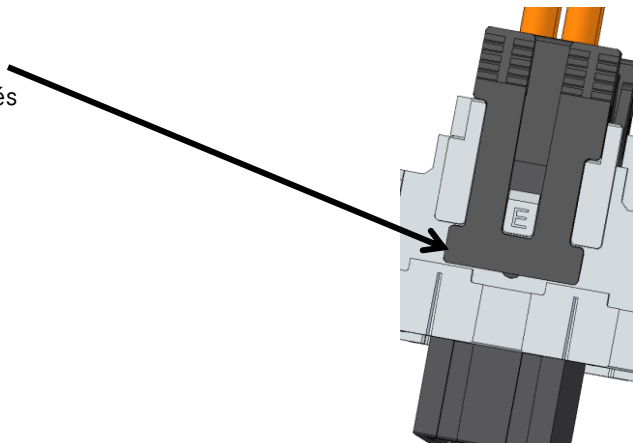

- 9 Adapter (Ringöse oder Gabelkabelschuh) muss gecrimpt werden  
*Adapter (eyelet or fork terminals) must be crimped*  
 Adapteur (oeillet ou bornes de fourche) doit etre sertir

PE Anschluss ab 10 mm<sup>2</sup> mit Adapter  
 PE Anschluss von 1 mm<sup>2</sup> bis 6 mm<sup>2</sup> mit Aderendhülse (muss gecrimpt werden)  
*PE connection from 10 mm<sup>2</sup> with adapter*  
*PE connection from 1 mm<sup>2</sup> to 6 mm<sup>2</sup> with wire end sleeve (must be crimped)*  
 Borne de terre á partir de 10 mm<sup>2</sup> avec adaptateur  
 Borne de terre de 1 mm<sup>2</sup> á 6 mm<sup>2</sup> avec embout (doit etre sertie)

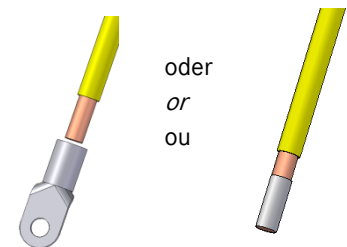

- 10 PE Schraube mit 1,2 Nm anziehen  
*Torque PE screw with 1,2 Nm*  
 Revisser la borne de terre avec 1,2 Nm

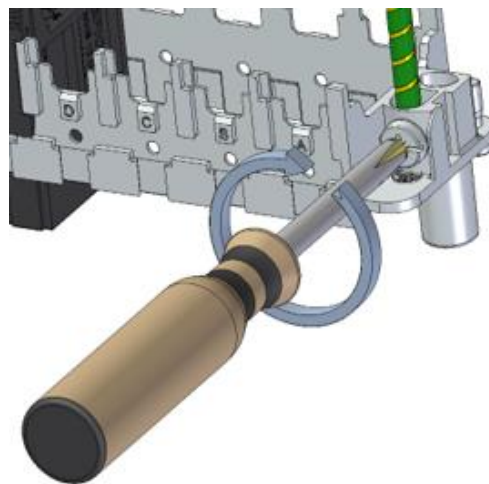

**ACHTUNG:** Es darf nur ein PE Leiter mit Adapter oder mit Aderendhülse pro PE Schraube angeschlossen werden  
**CAUTION:** Only one PE conductor with wire end sleeve or adapter shall be connected per PE screw  
**ATTENTION:** Ne peut etre connecté q´une seule borne de terre avec adaptateur ou avec embout par vis de terre



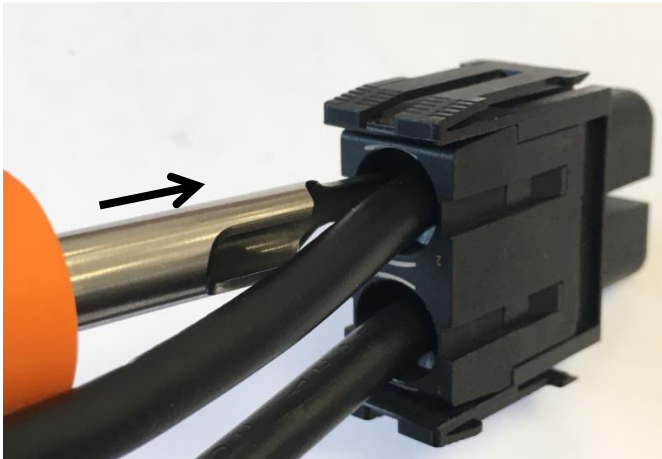

44423364	<b>Montageanleitung</b> <b>Assembly instruction</b>	
Gültig ab/ valid from 26.04.2022	<b>EPIC® MHS 2 40A CM</b> <b>EPIC® MHB 2 40A CM</b>	

- 1 1 Demontage der eingerasteten Kontakte mittels Lösewerkzeug. Art.-Nr.: 44423268  
*Removal of the snapped in contacts by using the removal tool. Art.-No.: 44423268*  
 Démontage des contacts verrouillés à l'aide d'un outil de déverrouillage. Art. No. 44423268
1. Lösewerkzeug von hinten in die Kontaktkammer schieben.  
*Push the removal tool from the back side into the contact chamber*  
 Poussez l'outil de déverrouillage dans la chambre de contact par l'arrière.

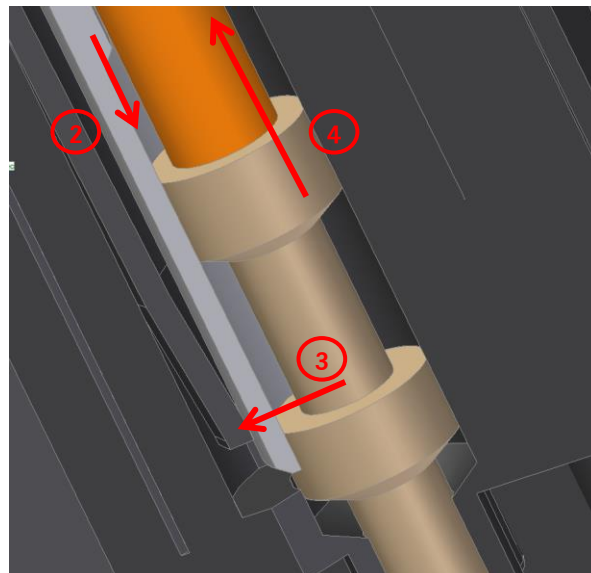
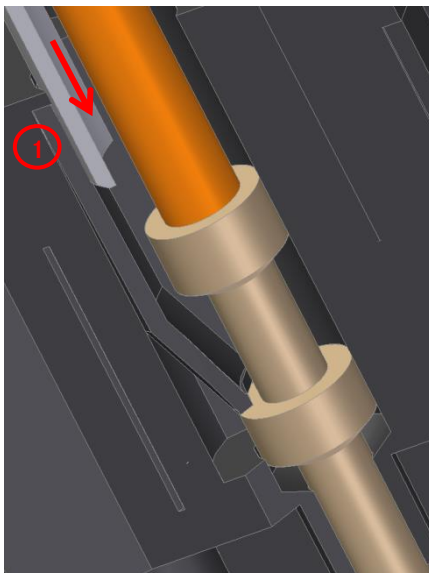

2. Das Lösewerkzeug bis zum Anschlag in die Kontaktkammer schieben.  
*Push the release tool into the contact chamber as far as it will go.*  
 Pousser l'outil de déverrouillage dans la chambre de contact jusqu'à la butée.
3. Die Haltefeder wird zurückgedrückt.  
*The retaining spring is pushed back.*  
 Le ressort de retenue est pressé ensemble.
4. Den Kontakt aus der Kontaktkammer nach hinten ziehen.  
*Remove the contact to the back side of the contact chamber.*  
 Tirez le contact vers l'arrière hors de la chambre de contact.



44423364	<b>Montageanleitung</b> <b>Assembly instruction</b>	
Gültig ab / valid from 26.04.2022	<b>EPIC® MHS 2 40A CM</b> <b>EPIC® MHB 2 40A CM</b>	

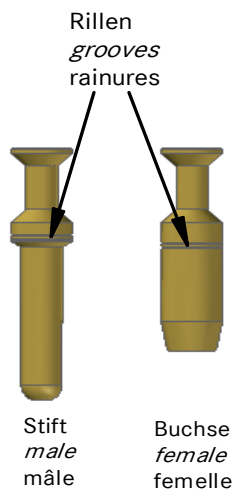

(4,0; 6,0 u 10 mm<sup>2</sup>)

Artikelnummer <i>Material number</i> Numero de l'article	Artikelbeschreibung <i>Material description</i> Description de l'article	Kontakttyp <i>Contact type</i> Type de contact	Leiterquerschnitt <i>Conductor cross-section</i> Section de conducteur [mm <sup>2</sup> ]	Oberfläche <i>Surface</i> Superficie	Abisolierlänge <i>Stripping length</i> Longueur de dénudage [mm]	Rillenanzahl <i>Number of grooves</i> Nombre de rainures
44423250	EPIC® MH SCEM AG 1.5sqmm D=4.0	Stift	1,5	Ag	10,5±0,5	2
44423255	EPIC® MH BCEM AG 1.5sqmm D=4.0	Buchse	1,5	Ag	10,5±0,5	2
44423251	EPIC® MH SCEM AG 2.5sqmm D=4.0	Stift	2,5	Ag	10,5±0,5	3
44423256	EPIC® MH BCEM AG 2.5sqmm D=4.0	Buchse	2,5	Ag	10,5±0,5	3
44423252	EPIC® MH SCEM AG 4sqmm D=4.0	Stift	4	Ag	15,5±0,5	0
44423257	EPIC® MH BCEM AG 4sqmm D=4.0	Buchse	4	Ag	15,5±0,5	0
44423253	EPIC® MH SCEM AG 6sqmm D=4.0	Stift	6	Ag	15,5±0,5	1
44423258	EPIC® MH BCEM AG 6sqmm D=4.0	Buchse	6	Ag	15,5±0,5	1
44423254	EPIC® MH SCEM AG 10sqmm D=4.0	Stift	10	Ag	15,5±0,5	2
44423259	EPIC® MH BCEM AG 10sqmm D=4.0	Buchse	10	Ag	15,5±0,5	2

44423364	<b>Montageanleitung</b> <b>Assembly instruction</b>	
Gültig ab/ valid from 26.04.2022	<b>EPIC® MHS 2 40A CM</b> <b>EPIC® MHB 2 40A CM</b>	

Buchsenrahmen: Mit kleinen Buchstaben  
gekennzeichnet  
*Female Frame: Marked with small letters*  
Femelle cadre: Marqué avec de petites  
lettres

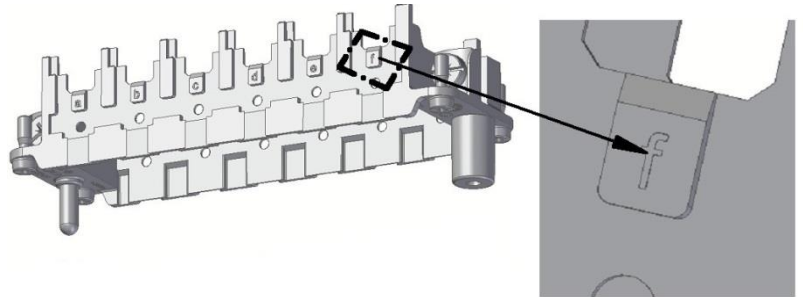

Stiftrahmen: Mit großen Buchstaben  
gekennzeichnet  
*Male Frame: Marked with capital letters*  
Mâle cadre: Marqué avec de grandes  
lettres

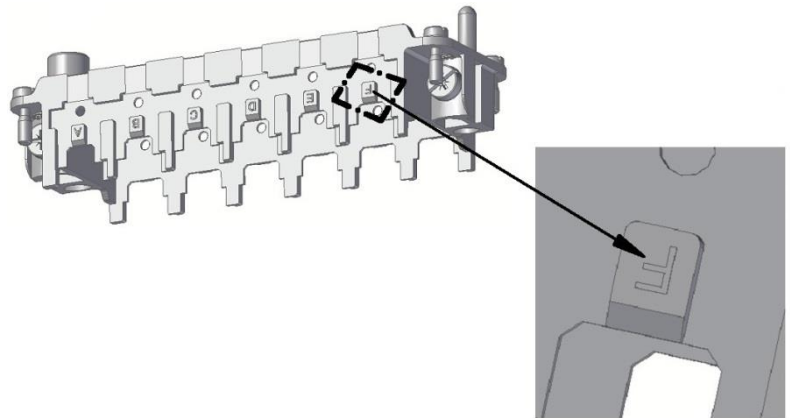

Artikelnummer <i>Material number</i> Numero de l'article	Artikelbeschreibung <i>Material description</i> Description de l'article	Kontakttyp <i>Contact type</i> Type de contact	Slot <i>Slot</i> Connecteur
<b>EPIC® MH 6 MULTIRAHMEN</b>			
44423234	EPIC® MHS 6 R (A, B)	Stift	2
44423235	EPIC® MHB 6 R (a, b)	Buchse	2
<b>EPIC® MH 10 MULTIRAHMEN</b>			
44423236	EPIC® MHS 10 R (A, B, C)	Stift	3
44423237	EPIC® MHB 10 R (a, b, c)	Buchse	3
<b>EPIC® MH 16 MULTIRAHMEN</b>			
44423238	EPIC® MHS 16 R (A, B, C, D)	Stift	4
44423239	EPIC® MHB 16 R (a, b, c, d)	Buchse	4
<b>EPIC® MH 24 MULTIRAHMEN</b>			
44423240	EPIC® MHS 24 R (A, B, C, D, E, F)	Stift	6
44423241	EPIC® MHB 24 R (a, b, c, d, e, f)	Buchse	6

44423364	<b>Montageanleitung</b> <b>Assembly instruction</b>	
Gültig ab/ valid from 26.04.2022	EPIC® MHS 2 40A CM EPIC® MHB 2 40A CM	

WERKZEUGE			
Artikelnummer <i>Material number</i> Numero de l'article	Artikelbeschreibung <i>Material description</i> Description de l'article	Version <i>Version</i> Version	Bemerkung <i>Comment</i> Remarque
11147000	Crimpzange <i>Crimping tool</i> Pince á setir	Im Werkzeugkoffer <i>In tool case</i> Dans la boîte a outils	Ohne Crimpbacken, ohne Locator <i>Without Crimp die and Locator</i> Sans Mâchoires á sertissage et Localisation
11147001	Crimmmaschine <i>Crimping machine</i> Machine ásertir	Pneumatisch, 5-10 bar <i>Pneumatic, 5-10 bar</i> Pneumatique, 5-10 bar	Ohne Crimpbacken, ohne Locator <i>Without Crimp die and Locator</i> Sans Mâchoires á sertissage et Localisation
11147100	Crimpingbacken <i>Crimping die</i> Mâchoires á sertissage	Für Crimpwerkzeug 11147000, 11147001	Für Kontakte MH-4 gedreht <i>For Contacts MH-4 drilled</i> Pour contacts MH-4 tourner
11147200	Locator <i>Locator</i> Localisateur	Für Crimpwerkzeuge <i>For crimping tool</i> Pour la machine ásertir	Für Kontakte MH-4 gedreht <i>For Contacts MH-4 drilled</i> Pour contacts MH-4 tourner
11182501	Lösewerkzeug <i>Extraction tool</i> Outil d'extraction		Für Kontakte MH-4 gedreht <i>For Contacts MH-4 drilled</i> Pour contacts MH-4 tourner

Werkzeuge: Zum Crimpen und Lösen der Kontakte  
*Tools: For crimping and loosening the contacts.*  
 Outils: Pour sertir et desserrer les contacts

11147201  
Locator  
*Locator*  
Localisateur  
d'extraction

44423268  
Lösewerkzeug  
*Extraction tool*  
Outil

11147000  
Crimpzange  
*Crimping tool*  
Pince á setir

11147100 bzw 11147101  
Crimpbacken  
*Crimp die*  
Mâchoires á sertissage



44423364	<b>Montageanleitung</b> <b>Assembly instruction</b>	
Gültig ab / valid from 26.04.2022	<b>EPIC® MHS 2 40A CM</b> <b>EPIC® MHB 2 40A CM</b>	



11147100

1,5, 2,5 u. 4 mm<sup>2</sup>



11147101

4, 6 u. 10 mm

Geeignet für beide Crimpbacken nach  
180° Drehung  
*Suitable for both crimp dies after  
rotating by 180°*  
Convient pour les deux matrices de  
sertissage après une rotation de 180°



**ACHTUNG: NICHT UNTER LAST STECKN ODER TRENNEN**

**CAUTION: DO NOT DISCONNECT UNDER LOAD**



**ATTENTION: NE PAS UTILISER POUR COUPLER LE COURANT**



U.I. Lapp GmbH  
Schulze-Delitzsch-Strasse 25  
D-70565 Stuttgart  
[www.lappgroup.com](http://www.lappgroup.com)