

DATA SHEET

Air-termination rods on tripod L-6000mm

Product code

516019

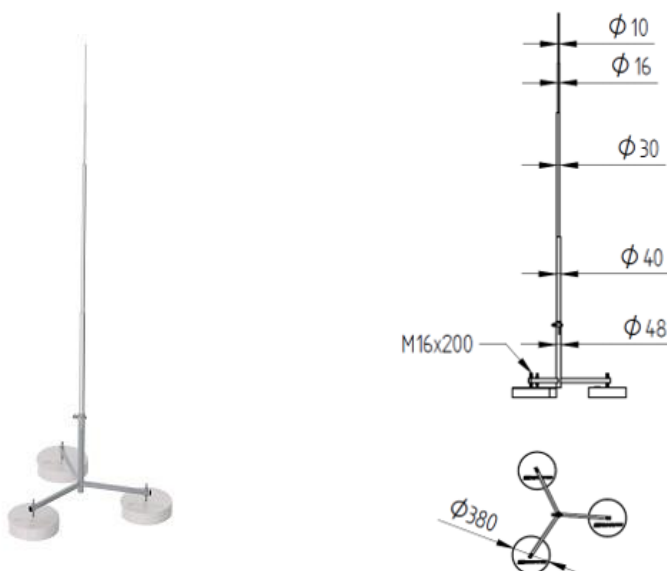

Technical description

Lightning protection mast for protecting electrical equipment on the roof from direct lightning discharge. The set consists of: spire, concrete bases (3pcs), tripod and wire connector. Wind resistance in accordance with EN 1993-1-1 and EN 1999-1-1 Eurocode, wind standards.

Technical data

| | |
|---|---|
| Material | Hot dip galvanized steel, StZn / Aluminum, Alu / Concrete |
| Weight (1 unit) | 72,68 kg |
| In accordance with the standard | EN 62305 |
| Meets the requirements of the standard | EN 1991-1-4 |
| Ean code | 5903699804421 |
| Customs code | 85354000 |

Due to continuous technological development, the company reserves the right to change the technical parameters of the products.
The illustrations shown are not binding.