

## DATA SHEET

### Straightener for lightning protection conductors

#### Product code

600111

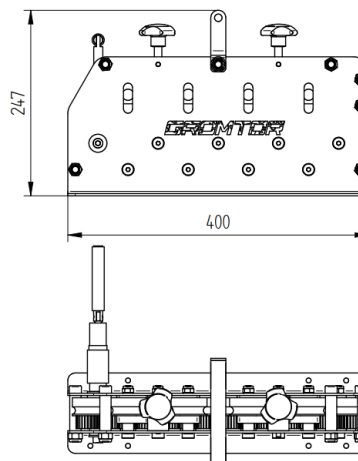
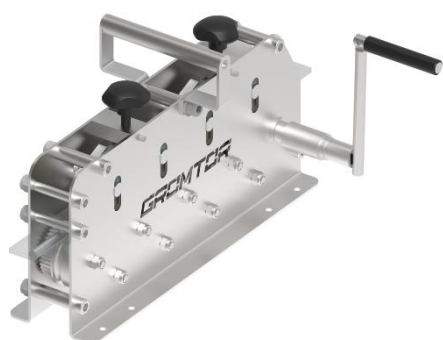

#### Technical description

Straightener for lightning protection conductors: wire  $\varnothing 8-10\text{mm}$  and flat conductor  $\geq 50\text{mm}$ .

#### Technical data

Material	Galvanized steel, StGI
Weight (1 unit)	14 kg
In accordance with the standard	PN-EN-62305
Ean code	5903699804957
Customs code	85359000

Due to continuous technological development, the company reserves the right to change the technical parameters of the products.  
The illustrations shown are not binding.